



Standard range

CLAMPING TECHNOLOGY

CLAMPING TECHNOLOGY COMPETENCE

Perfect clamping for every application

As an international business, WTE Präzisionstechnik GmbH is a technologically orientated organisation that, with its design and development department, produces innovations for the clamping technology sector. Core competencies are in precision drill chuck systems, in the hydraulic chucking sector and in shrinking technology. In the area of precision drill chucks we have achieved market leadership in Europe. Further products in high-precision clamping technology will follow.

We can count on highly qualified and committed employees. Currently our company employs approx. 150 employees who enjoy continuous internal further training to be able to satisfy the claim to high quality.

Not only the ongoing development and innovations for solving production-specific problems, but also the steady strengthening of the German facilities are at the core of our philosophy. With the construction of a third production building, we laid the foundation for consolidating Germany as a production location and therefore created more jobs in the region.

For all applications

WTE offers the right chuck for every machining operation. All types of machining – whether milling, drilling from solid or special processes such as trochoidal or helix milling, as well as reaming and fine boring – are covered with innovative clamping devices.

The right technology for your manufacturing

WTE offers a wide range of technologies to clamp your tools reliably. Thanks to an innovative manufacturing process, the chucks impress due to high torque transmission, ideal damping properties as well as an outstanding rigidity of the system. All chucks are balanced to a balancing quality: G 2.5 at 25,000 rpm (drill chuck 6.3 at 25,000 rpm)

The most modern manufacturing facilities

You benefit from us – from state-of-the-art technology, years of experience and the resulting expertise, clamping devices are developed and designed at WTE. The latest production facilities are being further expanded and modernised. Additive manufactured chucks push the boundaries by making the chuck “from a single cast” and making the technology usable for a much wider range of applications.





Comprehensive standard range

You will find the right clamping device for almost all spindle connections. Starting with hydraulic expansion and shrinking technology through to manual clamping technology and adapters, the WTE standard range includes a wide variety of connections, lengths and variants. Clamping systems from the WTE standard range are available from stock at any time and an extensive spare parts warehouse for all products ensures that the clamping devices can be used again quickly.

Sustainability in machining

Longer clamping, less energy consumption – that's why WTE offers state-of-the-art hydraulic chucks as a more sustainable alternative to the classic shrink chuck. In addition, hydraulic chucks have a ten times longer tool life, as the material is not worn out by shrinking processes. A longer tool life also saves resources and, in case of repair, damaged clamping devices can be reconditioned.

Service, support, training

The requirements of modern machining applications make extensive technical consultation and support for customers the cornerstones of increased customer satisfaction, which in turn ensures long-lasting and good customer relationships. Service at WTE also means that customised seminars and trials are possible on the introduction of new tool versions to allow the customer's personnel to take advantage of the know-how of the on-site specialists. We guarantee a repair service for all WTE tools.





CONTENTS

01 Introduction

Product range	6
---------------------	---

02 Chucks

Product overview, selection guide, product ID codes	8
Hydraulic clamping technology	21
Shrinking technology	53
Mechanical tool clamping technology	73

03 Milling cutter arbors

Milling cutter arbors	113
-----------------------------	-----

04 Extensions and adapters

Extensions and adapters	123
-------------------------------	-----

05 Accessories and spare parts

Accessories and spare parts	135
-----------------------------------	-----

06 Technical appendix

Technical appendix	149
--------------------------	-----

PRODUCT RANGE



1. Shrink chuck

- 1.1 3° shrink chuck, slim design (from page 54)
- 1.2 4.5° shrink chuck (from page 58)

2. Hydraulic chuck

- 2.1 Hydraulic chuck, standard design (from page 38)
- 2.2 Hydraulic chuck, standard design (from page 36)
- 2.3 3° high performance holder, slim design (from page 22)
- 2.4 High performance holder, short heavy-duty design (from page 30)

3. Mechanical tool technology

- 3.1 NC standard drill chucks (from page 101)
- 3.2 CNC precision drill chucks (from page 78)
- 3.3 MICRO universal chucks (from page 104)



4. Milling cutter arbor

4.1 Vibration dampened design (from page 114)

5. Extensions and adapters

5.1 Modular HSK-A adapter (from page 128)

5.2 Hydraulic extensions (from page 126)



CHUCKS

Hydraulic chucks, shrink chucks and mechanical chucks.



PRODUCT OVERVIEW

Chucks for cylindrical shanks

WTE's clamping technology range guarantees performance and process reliability as well as radial run-out and changeover accuracy for every application. Manufactured using the most modern technologies, our specialists are continuously developing our chucks further.

In response to customers' requirements and situations, a large variety of systems have been made available in the standard range: from hydraulic expansion and shrink chucks to mechanical clamping systems for HB shanks and adapters.



Hydraulic clamping technology:

- High level of torque transmission
- Tool change in seconds without peripheral devices
- Extended tool life due to maximum radial run-out and repetition accuracy
- High flexibility when using reducing sleeves





Shrinking technology:

- High level of torque transmission and radial rigidity
- Long tool life through the use of high-temperature tool steel



Mechanical tool clamping technology:

- Simpler construction
- Easy handling
- High flexibility

Hydraulic clamping technology	Shrinking technology	
		
<p>HPH - High Performance Holder</p> <p>The High Performance Holder hydraulic chuck offers a high level of torque transmission, along with ideal damping properties, outstanding system rigidity and a radial run-out accuracy of < 3 µm.</p> <ul style="list-style-type: none"> - 3° slim design with a back taper of three degrees to avoid tool restrictions for use in contour-critical applications - Short heavy-duty design optionally available with resealable coolant outlets and optimal damping properties for long tool life even with demanding milling operations 	<p>Hydraulic chuck</p> <p>The hydraulic chuck is characterised by excellent vibration dampening and high radial run-out accuracy, guaranteeing optimal workpiece surfaces.</p> <ul style="list-style-type: none"> - Standard design - Ultra-short design: Compact design for high rigidity - Hydraulic chuck with compensation technology: Compensation of radial run-out errors across the entire system with easy handling 	<p>Shrink chuck</p> <p>Using the shrink chucks the tools can be accurately clamped for almost all machining operations. The high level of torque transmission and radial rigidity sets this chuck apart from the rest.</p> <ul style="list-style-type: none"> - 3° slim design with a back taper of three degrees to avoid tool restrictions for use in contour-critical applications - Design with two coolant outlets – resealable design - 4.5° standard design
<p>From page 21</p>		<p>From page 53</p>



Mechanical tool technology



Side lock chuck

This Mill Chuck side lock chuck is an impressive option with reliable clamping ability, easy handling and a good radial run-out.

- Easy to handle thanks to a differential screw
- Axial tool positioning can be defined using a spring system
- Decentralised coolant outlets for maximum process reliability
- High degree of process reliability during trochoidal machining



Precision drill chuck

The precision drill chuck convinces with its simple design and easy, straightforward handling. The clamping is reliably guaranteed independent of the direction of rotation, even at high spindle speeds.

- Wide clamping range
- Voltage independent of direction of rotation even at high spindle speeds
- Simple construction, straightforward to handle
- High degree of spindle speed strength
- Modular design allows drill chuck heads to be used with all tool connections



Hydraulic clamping technology



HPH - High Performance Holder

The HPH - High Performance Holder hydraulic chucks combine the damping properties of hydraulic clamping technology with the high clamping forces of shrinking technology. Thanks to an innovative manufacturing process, the chucks impress due to high torque transmission, ideal damping properties, outstanding system rigidity and a radial run-out accuracy of $< 3 \mu\text{m}$.

The rigidity nicht bending resistance is 1.4 times greater than a conventional shrink chuck in accordance with DIN 69882-8. In production, these advantages guarantee a high surface finish on the part, significantly higher machining speeds and therefore short machining times. The HPH properties prevent macroscopic flaws on the cutting edge of the tool and extend tool lives.

ADVANTAGES

- High level of torque transmission
- Thermal stability up to 170 °C (3° slim contour up to 120 °C)
- Tool change in seconds without peripheral devices



Hydraulic chuck

Due to their high radial run-out accuracy and the resulting even cutting action as well as the excellent vibration dampening, WTE's hydraulic chuck guarantees optimal workpiece finishes.

In addition, microstructure cracking on the tool's cutting edge is prevented by the hydraulic system, the tool lives are extended and therefore are costs reduced. High clamping reliability is ensured even at high spindle speeds. The chucks can be adjusted to the μ thanks to axial and radial length adjustment.

ADVANTAGES

- Radial or axial length adjustment to the μ
- No reduction in the clamping forces at high spindle speeds
- Extended tool life due to maximum radial run-out and repetition accuracy
- Tool change in seconds without peripheral devices



Shrinking technology



Shrink chuck

Using the WTE shrink chucks the tools can be accurately clamped for almost all milling operations. The high level of torque transmission and radial rigidity sets this chuck apart from the rest. Long-term radial run-out accuracy and accuracy of repetition of $< 3 \mu\text{m}$ in the location bore guarantee high dimensional accuracy on the workpiece.

The shrink chucks are finely balanced as standard so that high surface finishes and long tool lives are ensured. The standard range of shrink fit chucks includes designs with 4.5° contours with slim outer contours of 3° as well as with resealable coolant outlets.

ADVANTAGES

- High level of torque transmission and radial rigidity
- Long tool life through the use of high-temperature tool steel
- Wide range of possible combinations of shrink chucks and extensions



Mechanical tool clamping technology



MillChuck, HB

The new Mill Chuck HB side lock chuck impresses with strong clamping, simple handling and a high radial run-out accuracy. The location bore is created with significantly more precision. This reduces the radial play of the clamped tool and considerably improves the radial run-out. The large tolerance on the lateral clamping surface is also compensated for. To achieve this, WTE uses a spring element in the connection that enables a defined form fit between the tool and connection. Coolant channels parallel to the axis in the clamping range also ensure improved coolant supply.

ADVANTAGES

- Easy to handle thanks to use of a differential screw
- Maximum cost-effectiveness and precision
- Axial tool positioning can be defined using a spring system
- Decentralised coolant outlets for maximum coolant flow

Precision and standard drill chucks









Mechanical chucks impress due to their simple construction and the uncomplicated handling. The clamping is reliably guaranteed independent of the direction of rotation, even at high spindle speeds. The standard range for mechanical tool clamping includes precision drill chucks that are also available in a micro design with direct clamping from 0.2 mm. Drill chucks are available with all forms of machine-side tool bodies.

ADVANTAGES

- Simple construction, straightforward to handle
- Wide clamping range
- Safe clamping independent of direction of rotation
- High degree of spindle speed strength
- Modular design allows drill chuck heads to be used with all tool connections

Selection of a chuck

The optimal chuck for every application – four steps to the right chuck

1 TECHNOLOGY	2 DESIGN	3 APPLICATION						
		MILLING			DRILLING	REAMING	TURNING	
		HFC	Roughing	Finishing				
								
 Hydraulic clamping technology	HPH - High Performance Holder	Narrow design, 3°	<input type="checkbox"/>	<input type="checkbox"/>	<input checked="" type="checkbox"/>	<input checked="" type="checkbox"/>	<input checked="" type="checkbox"/>	<input type="checkbox"/>
		Short heavy-duty design ¹⁾	<input checked="" type="checkbox"/>	<input checked="" type="checkbox"/>	<input checked="" type="checkbox"/>	<input checked="" type="checkbox"/>	<input checked="" type="checkbox"/>	<input type="checkbox"/>
		Short heavy-duty design with coolant outlets ²⁾	<input checked="" type="checkbox"/>	<input checked="" type="checkbox"/>	<input checked="" type="checkbox"/>	<input checked="" type="checkbox"/>	<input checked="" type="checkbox"/>	<input type="checkbox"/>
	Hydraulic chuck	With axial length adjustment	<input type="checkbox"/>	<input type="checkbox"/>	<input checked="" type="checkbox"/>	<input checked="" type="checkbox"/>	<input checked="" type="checkbox"/>	<input type="checkbox"/>
		With radial length adjustment	<input type="checkbox"/>	<input type="checkbox"/>	<input checked="" type="checkbox"/>	<input checked="" type="checkbox"/>	<input checked="" type="checkbox"/>	<input type="checkbox"/>
		With compensation technology ³⁾	<input type="checkbox"/>	<input type="checkbox"/>	<input checked="" type="checkbox"/>	<input checked="" type="checkbox"/>	<input checked="" type="checkbox"/>	<input type="checkbox"/>
		Hydro-Turn chuck	<input type="checkbox"/>	<input type="checkbox"/>	<input type="checkbox"/>	<input type="checkbox"/>	<input type="checkbox"/>	<input checked="" type="checkbox"/>
 Shrinking technology	Shrink chuck	Narrow design, 3°	<input type="checkbox"/>	<input type="checkbox"/>	<input checked="" type="checkbox"/>	<input checked="" type="checkbox"/>	<input checked="" type="checkbox"/>	<input type="checkbox"/>
		4.5°	<input checked="" type="checkbox"/>	<input checked="" type="checkbox"/>	<input checked="" type="checkbox"/>	<input checked="" type="checkbox"/>	<input checked="" type="checkbox"/>	<input type="checkbox"/>
		With coolant outlets ²⁾	<input checked="" type="checkbox"/>	<input checked="" type="checkbox"/>	<input checked="" type="checkbox"/>	<input checked="" type="checkbox"/>	<input checked="" type="checkbox"/>	<input type="checkbox"/>
 Mechanical tool clamping technology	Mechanical systems	MillChuck, HB	★	<input checked="" type="checkbox"/>	<input checked="" type="checkbox"/>	<input checked="" type="checkbox"/>	<input checked="" type="checkbox"/>	<input type="checkbox"/>
		CNC precision drill chucks	<input type="checkbox"/>	<input type="checkbox"/>	<input type="checkbox"/>	<input checked="" type="checkbox"/>	<input checked="" type="checkbox"/>	<input type="checkbox"/>
		Standard NC drill chucks	<input type="checkbox"/>	<input type="checkbox"/>	<input type="checkbox"/>	<input checked="" type="checkbox"/>	<input type="checkbox"/>	<input type="checkbox"/>
		MICRO universal chucks	<input type="checkbox"/>	<input type="checkbox"/>	<input type="checkbox"/>	<input checked="" type="checkbox"/>	<input checked="" type="checkbox"/>	<input type="checkbox"/>
		Milling cutter arbor, vibration-dampened	★	★	★	<input type="checkbox"/>	<input type="checkbox"/>	<input type="checkbox"/>

★ = 1. choice | ■ = highly suitable | ◻ = suitable in some situations | □ = not suitable

¹⁾ Short/heavy-duty design: Compact design for high rigidity.

²⁾ With coolant outlets: Chuck with additional decentral coolant outlets that, optionally, are resealable.

³⁾ With compensation technology: Alignment feature on the chuck for radial alignment to compensate for radial run-out errors on the overall system.

4 CONNECTION

	 HSK-A	 HSK-E	 HSK-F	 PSC	 SK	 BT	 Module	 Cylindrical shank
	from page 22	from page 34			from page 25	from page 27		
	from page 30			from page 35	from page 31	from page 32		
	from page 30				from page 31			
	from page 36	from page 48	from page 49		from page 38	from page 39	from page 40	
	from page 41							
	from page 44				from page 45	from page 46		
								from page 51
	from page 54				from page 56	from page 57		
	from page 58	from page 71			from page 61	from page 64	from page 67	
	from page 68				from page 70			
	from page 76				from page 77			
	from page 80	from page 90	from page 89	from page 99	from page 81	from page 84		from page 95
					from page 101	from page 103		
	from page 104	from page 105			from page 106	from page 107		from page 108
	from page 116				from page 117			

General information

We supply exclusively on the basis of our Terms of Delivery and Payment (see wte.mapal.com). With the publication of this catalogue, the corresponding previous versions become invalid. Changes and deviations from standards reserved.

No claims shall be derived from printing errors in technical data. Reprinting, in whole or in part, is not permitted without our express approval.

Explanation of the dimensions and abbreviations

d = clamping diameter, reducing sleeve
 d₁ = clamping diameter
 d₂ = min. tool restriction
 d₃ = max. tool restriction

l = clamping depth (reducing sleeve)
 = length (stop screw)
 = length adjustment dimension (length pre-adjuster)

l₁ = projection length
 L_{1max.} = projection length with drill chuck
 G = thread
 SW = wrench size

Order designation / Technical specification

SERIES

1 5

Chuck shank *

15: Steep taper
 16: HSK-A
 17: HSK-F
 18: HSK-E
 22: BT
 27: BT-FC (face connection)

DIMENSIONS

5 0 7

Product family

5xx: Hydraulic chuck
 40x: HPH - High Performance Holder
 30x: Shrink chuck
 296: CNC precision drill chucks
 297: Standard NC drill chucks
 236: MICRO universal chucks

4 0

Nominal size
 Chuck shank

0 6

Clamping diameter d₁ in mm

CONSTRUCTION

K K B

Coolant supply

Z: Coolant supply centrally through the tool holder or via the collar.
 KKB: Additional coolant outlets.
 ZBA: Coolant supply for tools without cooling channels.

For tools without coolant supply, this identification is omitted.

1 5 0

Projection length l₁
 in mm

* The numbers shown for chuck shanks and product families represent the standard scopes included in the range. Special shanks and further designations within the product families may differ in the numerical designation.







HYDRAULIC CLAMPING TECHNOLOGY

High Performance Holder

3° slim design with axial length adjustment	22
Short heavy design, with axial length adjustment	30

Hydraulic chuck

With axial length adjustment	36
With radial length adjustment	41
Hydraulic chuck compensation	44

Hydraulic clamping inserts for lathes

Turning technology	50
Hydro-Turn chuck	51

High Performance Holder HPH

With axial tool length adjustment

HSK-A (hollow shank taper form A) shank according to DIN 69893-1

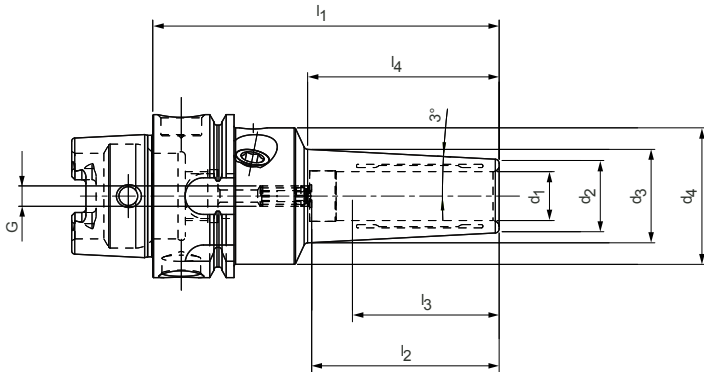

3° slim design | Preferred series available from stock

HSK-A	Dimensions								G	Order designation	Order no.
	d ₁	d ₂	d ₃	d ₄	l ₁	l ₂	l ₃	l ₄			
40	3,0	9,0	13,8	33,5	85,0	28,0	16,0	45,0	M2,5	16.404.40.03.Z/85	30817224
40	4,0	10,0	14,8	33,5	85,0	28,0	12,0	45,0	M2,5	16.404.40.04.Z/85	30817227
40	5,0	11,0	15,8	33,5	85,0	28,0	8,0	45,0	M2,5	16.404.40.05.Z/85	30817230
40	6,0	12,0	16,9	33,5	85,0	37,0	10,0	46,0	M5	16.404.40.06.Z/85	30817232
40	8,0	14,0	18,9	33,5	85,0	37,0	10,0	46,0	M6	16.404.40.08.Z/85	30817236
40	10,0	16,0	21,0	33,5	85,0	41,0	10,0	47,0	M5	16.404.40.10.Z/85	30817238
40	12,0	18,0	23,0	33,5	85,0	46,0	10,0	47,0	M5	16.404.40.12.Z/85	30817242
63	3,0	9,0	16,7	50,0	120,0	28,0	16,0	73,0	M2,5	16.404.63.03.Z/120	30727351
63	4,0	10,0	17,7	50,0	120,0	28,0	12,0	73,0	M2,5	16.404.63.04.Z/120	30727356
63	5,0	11,0	18,7	50,0	120,0	28,0	8,0	73,0	M2,5	16.404.63.05.Z/120	30727359
63	6,0	12,0	19,8	50,0	120,0	37,0	10,0	74,0	M5	16.404.63.06.Z/120	30655463
63	7,0	13,0	20,8	50,0	120,0	37,0	10,0	74,0	M5	16.404.63.07.Z/120	30856764
63	8,0	14,0	21,8	50,0	120,0	37,0	10,0	74,0	M6	16.404.63.08.Z/120	30655465
63	9,0	15,0	22,8	50,0	120,0	37,0	10,0	74,0	M6	16.404.63.09.Z/120	30856766
63	10,0	16,0	23,8	50,0	120,0	41,0	10,0	74,0	M8x1	16.404.63.10.Z/120	30655466
63	11,0	17,0	24,8	50,0	120,0	41,0	10,0	74,0	M8x1	16.404.63.11.Z/120	30856768
63	12,0	18,0	25,9	50,0	120,0	46,0	10,0	75,0	M10x1	16.404.63.12.Z/120	30655467
63	13,0	20,0	27,9	50,0	120,0	46,0	10,0	75,0	M10x1	16.404.63.13.Z/120	30856770
63	14,0	22,0	29,5	50,0	120,0	46,0	10,0	71,0	M10x1	16.404.63.14.Z/120	30782387
63	16,0	24,0	31,5	50,0	120,0	49,0	10,0	71,5	M12x1	16.404.63.16.Z/120	30696274
63	18,0	26,0	33,6	50,0	120,0	49,0	10,0	72,0	M12x1	16.404.63.18.Z/120	30696276
63	20,0	28,0	35,6	50,0	120,0	51,0	10,0	72,0	M16x1	16.404.63.20.Z/120	30696278
100	3,0	9,0	16,4	50,0	120,0	28,0	16,0	70,0	M2,5	16.404.100.03.Z/120	30856775
100	4,0	10,0	17,4	50,0	120,0	28,0	12,0	70,0	M2,5	16.404.100.04.Z/120	30845043
100	5,0	11,0	18,4	50,0	120,0	28,0	8,0	70,0	M2,5	16.404.100.05.Z/120	30856776
100	6,0	12,0	19,4	50,0	120,0	37,0	10,0	70,0	M5	16.404.100.06.Z/120	30856777
100	8,0	14,0	21,5	50,0	120,0	37,0	10,0	71,0	M6	16.404.100.08.Z/120	30856779
100	10,0	16,0	23,5	50,0	120,0	41,0	10,0	71,0	M8x1	16.404.100.10.Z/120	30856781
100	12,0	18,0	25,6	50,0	120,0	46,0	10,0	72,0	M10x1	16.404.100.12.Z/120	30856783
100	14,0	22,0	29,2	50,0	120,0	46,0	10,0	68,0	M10x1	16.404.100.14.Z/120	30856785
100	16,0	24,0	31,2	50,0	120,0	49,0	10,0	68,0	M12x1	16.404.100.16.Z/120	30856786
100	18,0	26,0	33,3	50,0	120,0	49,0	10,0	69,0	M12x1	16.404.100.18.Z/120	30856787
100	20,0	28,0	35,3	50,0	120,0	51,0	10,0	69,0	M16x1	16.404.100.20.Z/120	30845056

Slim design 3° | Available upon request

HSK-A	Dimensions								G	Order designation	Order no.
	d ₁	d ₂	d ₃	d ₄	l ₁	l ₂	l ₃	l ₄			
63	3,0	9,0	12,5	50,0	80,0	28,0	16,0	33,0	M2,5	16.404.63.03.Z/80	30962065
63	4,0	10,0	13,5	50,0	80,0	28,0	12,0	33,0	M2,5	16.404.63.04.Z/80	30962067
63	5,0	11,0	14,5	50,0	80,0	28,0	8,0	33,0	M2,5	16.404.63.05.Z/80	30962068
63	6,0	12,0	15,6	50,0	80,0	37,0	10,0	34,0	M5	16.404.63.06.Z/80	30962069
63	8,0	14,0	17,6	50,0	80,0	37,0	10,0	34,0	M6	16.404.63.08.Z/80	30962072
63	10,0	16,0	20,0	50,0	85,0	41,0	10,0	39,0	M8x1	16.404.63.10.Z/85	30962074
63	12,0	18,0	22,7	50,0	90,0	46,0	10,0	45,0	M10x1	16.404.63.12.Z/90	30962077
63	14,0	22,0	26,7	50,0	90,0	46,0	10,0	45,0	M10x1	16.404.63.14.Z/90	30962078
63	16,0	24,0	28,9	50,0	95,0	49,0	10,0	47,0	M12x1	16.404.63.16.Z/95	30962080
63	18,0	26,0	30,9	50,0	95,0	49,0	10,0	47,0	M12x1	16.404.63.18.Z/95	30962083
63	20,0	28,0	33,4	50,0	100,0	51,0	10,0	52,0	M16x1	16.404.63.20.Z/100	30962087

Dimensions in mm.

For accessories and spare parts see "Accessories and spare parts" section.

Additional dimensions and special designs available upon request.

High Performance Holder HPH

With axial tool length adjustment

HSK-A (hollow shank taper form A) shank according to DIN 69893-1

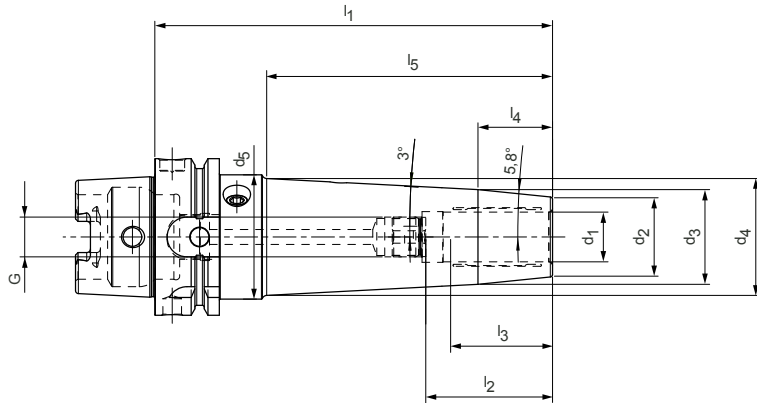

Slim design 3°, optimised contour for maximum bending resistance | Preferred series available from stock

HSK-A	Dimensions										G	Order designation	Order no.
	d ₁	d ₂	d ₃	d ₄	d ₅	l ₁	l ₂	l ₃	l ₄	l ₅			
63	3,0	13,0	27,3	31,5	50,0	160,0	28,0	16,0	70,0	110,0	M2,5	16.404.63.03.Z/160	30857133
63	3,0	13,0	27,3	35,8	50,0	200,0	28,0	16,0	70,0	151,0	M2,5	16.404.63.03.Z/200	30857148
63	4,0	14,0	28,3	32,5	50,0	160,0	28,0	12,0	70,0	110,0	M2,5	16.404.63.04.Z/160	30857138
63	4,0	14,0	28,3	36,8	50,0	200,0	28,0	12,0	70,0	151,0	M2,5	16.404.63.04.Z/200	30857151
63	5,0	15,0	29,3	33,5	50,0	160,0	28,0	8,0	70,0	110,0	M2,5	16.404.63.05.Z/160	30857140
63	5,0	15,0	29,3	37,8	50,0	200,0	28,0	8,0	70,0	151,0	M2,5	16.404.63.05.Z/200	30857152
63	6,0	16,0	28,2	33,6	50,0	160,0	37,0	10,0	60,0	111,0	M5	16.404.63.06.Z/160	30727381
63	6,0	16,0	28,2	37,9	50,0	200,0	37,0	10,0	60,0	152,0	M5	16.404.63.06.Z/200	30720821
63	8,0	18,0	28,2	34,6	50,0	160,0	37,0	10,0	50,0	111,0	M6	16.404.63.08.Z/160	30727383
63	8,0	18,0	28,2	38,9	50,0	200,0	37,0	10,0	50,0	152,0	M6	16.404.63.08.Z/200	30720823
63	10,0	20,0	29,2	36,3	50,0	160,0	41,0	10,0	45,0	113,0	M8x1	16.404.63.10.Z/160	30727385
63	10,0	20,0	29,2	40,6	50,0	200,0	41,0	10,0	45,0	154,0	M8x1	16.404.63.10.Z/200	30720824
63	12,0	22,0	30,2	37,8	50,0	160,0	46,0	10,0	40,0	113,0	M10x1	16.404.63.12.Z/160	30727390
63	12,0	22,0	30,2	42,1	50,0	200,0	46,0	10,0	40,0	154,0	M10x1	16.404.63.12.Z/200	30720825
63	14,0	26,0	34,2	41,8	50,0	160,0	46,0	10,0	40,0	113,0	M10x1	16.404.63.14.Z/160	30857142
63	14,0	26,0	34,2	46,1	50,0	200,0	46,0	10,0	40,0	154,0	M10x1	16.404.63.14.Z/200	30857153
63	16,0	28,0	36,2	43,8	50,0	160,0	49,0	10,0	40,0	113,0	M12x1	16.404.63.16.Z/160	30857145
63	16,0	28,0	36,2	48,1	50,0	200,0	49,0	10,0	40,0	154,0	M12x1	16.404.63.16.Z/200	30857156
63	18,0	30,0	36,1	45,1	50,0	160,0	49,0	10,0	30,0	115,0	M12x1	16.404.63.18.Z/160	30857146
63	18,0	30,0	36,1	49,4	50,0	200,0	49,0	10,0	30,0	156,0	M12x1	16.404.63.18.Z/200	30857157
63	20,0	32,0	38,1	47,1	50,0	160,0	51,0	10,0	30,0	115,0	M16x1	16.404.63.20.Z/160	30857147
63	20,0	32,0	38,1	49,1	50,0	200,0	51,0	10,0	30,0	156,0	M16x1	16.404.63.20.Z/200	30857159

Dimensions in mm.

For accessories and spare parts see "Accessories and spare parts" section.

Additional dimensions and special designs available upon request.

High Performance Holder HPH

With axial tool length adjustment

SK shank according to ISO 7388-1 Form AD/AF

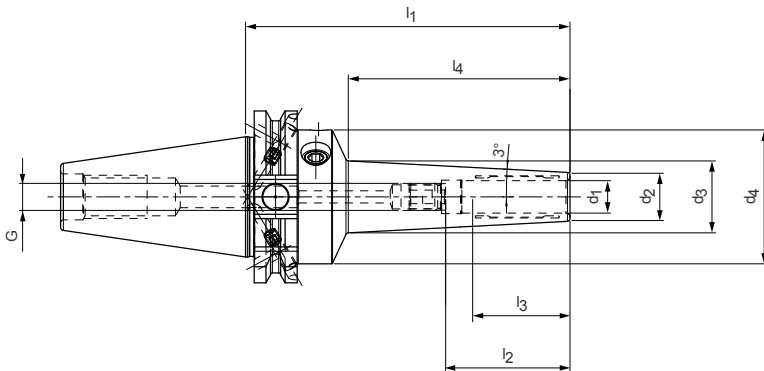

3° slim design | Preferred series available from stock

Steep taper	Dimensions								G	Order designation	Order no.
	d ₁	d ₂	d ₃	d ₄	l ₁	l ₂	l ₃	l ₄			
30*	3,0	9,0	13,2	40,0	80,0	28,0	16,0	40,0	M2,5	15.404.30.03.Z/80	30816303
30*	4,0	10,0	14,2	40,0	80,0	28,0	12,0	40,0	M2,5	15.404.30.04.Z/80	30816304
30*	5,0	11,0	15,3	40,0	80,0	28,0	8,0	41,0	M2,5	15.404.30.05.Z/80	30816305
30*	6,0	12,0	16,3	40,0	80,0	37,0	10,0	41,0	M5	15.404.30.06.Z/80	30816307
30*	8,0	14,0	18,3	40,0	80,0	37,0	10,0	41,0	M6	15.404.30.08.Z/80	30816308
30*	10,0	16,0	20,5	40,0	80,0	41,0	10,0	42,0	M8x1	15.404.30.10.Z/80	30816311
30*	12,0	18,0	22,5	40,0	80,0	46,0	10,0	42,0	M8x1	15.404.30.12.Z/80	30816312
40	3,0	9,0	17,4	49,5	120,0	28,0	16,0	80,0	M2,5	15.404.40.03.Z/120	30777071
40	4,0	10,0	18,4	49,5	120,0	28,0	12,0	80,0	M2,5	15.404.40.04.Z/120	30777072
40	5,0	11,0	19,4	49,5	120,0	28,0	8,0	80,0	M2,5	15.404.40.05.Z/120	30777073
40	6,0	12,0	20,4	49,5	120,0	37,0	10,0	80,0	M5	15.404.40.06.Z/120	30655468
40	8,0	14,0	22,4	49,5	120,0	37,0	10,0	80,0	M6	15.404.40.08.Z/120	30655469
40	10,0	16,0	24,5	49,5	120,0	41,0	10,0	81,0	M8x1	15.404.40.10.Z/120	30655470
40	12,0	18,0	26,6	49,5	120,0	46,0	10,0	82,0	M10x1	15.404.40.12.Z/120	30655471
40	14,0	22,0	30,3	49,5	120,0	46,0	10,0	79,0	M10x1	15.404.40.14.Z/120	30782464
40	16,0	24,0	32,3	49,5	120,0	49,0	10,0	79,0	M12x1	15.404.40.16.Z/120	30782465
40	18,0	26,0	34,4	49,5	120,0	49,0	10,0	80,0	M12x1	15.404.40.18.Z/120	30782467
40	20,0	28,0	36,4	49,5	120,0	51,0	10,0	80,0	M16x1	15.404.40.20.Z/120	30782468

* Design: Taper shank size is not available in the AD/AF combination design

Slim design 3° | Available upon request

40	3,0	9,0	13,2	49,5	80,0	28,0	16,0	40,0	M2,5	15.404.40.03.Z/80	30962184
40	4,0	10,0	14,2	49,5	80,0	28,0	12,0	40,0	M2,5	15.404.40.04.Z/80	30962185
40	5,0	11,0	15,2	49,5	80,0	28,0	8,0	40,0	M2,5	15.404.40.05.Z/80	30962188
40	6,0	12,0	16,2	49,5	80,0	37,0	10,0	40,0	M5	15.404.40.06.Z/80	30962213
40	8,0	14,0	18,2	49,5	80,0	37,0	10,0	40,0	M6	15.404.40.08.Z/80	30962214
40	10,0	16,0	20,3	49,5	80,0	41,0	10,0	41,0	M8x1	15.404.40.10.Z/80	30962216
40	12,0	18,0	22,4	49,5	80,0	46,0	10,0	42,0	M10x1	15.404.40.12.Z/80	30962217
40	14,0	22,0	26,4	49,5	80,0	46,0	10,0	42,0	M10x1	15.404.40.14.Z/80	30962243
40	16,0	24,0	28,2	49,5	80,0	49,0	10,0	40,0	M12x1	15.404.40.16.Z/80	30962244
40	18,0	26,0	30,2	49,5	80,0	49,0	10,0	40,0	M12x1	15.404.40.18.Z/80	30962245
40	20,0	28,0	32,7	49,5	85,0	51,0	10,0	45,0	M16x1	15.404.40.20.Z/85	30962246

Dimensions in mm.

For accessories and spare parts see "Accessories and spare parts" section.
Additional dimensions and special designs available upon request.

High Performance Holder HPH

With axial tool length adjustment

SK shank according to ISO 7388-1 Form AD/AF

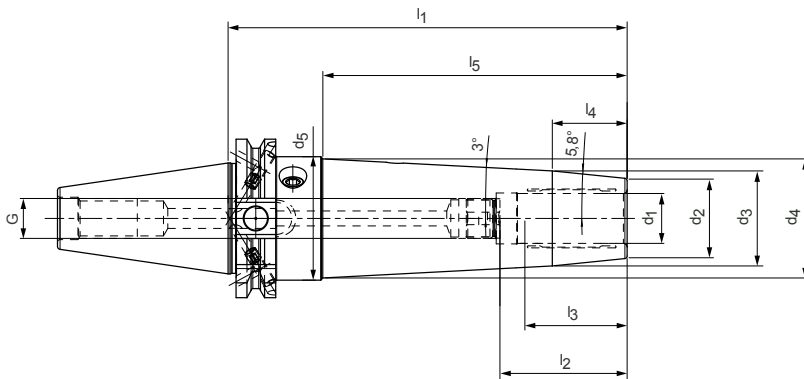

Slim design 3°, optimised contour for maximum bending resistance | Preferred series available from stock

Steep taper	Dimensions										G	Order designation	Order no.
	d ₁	d ₂	d ₃	d ₄	d ₅	l ₁	l ₂	l ₃	l ₄	l ₅			
40	3,0	13,0	27,2	49,5	49,5	160,0	28,0	16,0	70,0	117,0	M2,5	15.404.40.03.Z/160	30857255
40	3,0	13,0	27,2	49,5	49,5	200,0	28,0	16,0	70,0	158,0	M2,5	15.404.40.03.Z/200	30857353
40	4,0	14,0	28,2	49,5	49,5	160,0	28,0	12,0	70,0	117,0	M2,5	15.404.40.04.Z/160	30857256
40	4,0	14,0	28,2	49,5	49,5	200,0	28,0	12,0	70,0	158,0	M2,5	15.404.40.04.Z/200	30857355
40	5,0	15,0	29,2	49,5	49,5	160,0	28,0	8,0	70,0	117,0	M2,5	15.404.40.05.Z/160	30857257
40	5,0	15,0	29,2	49,5	49,5	200,0	28,0	8,0	70,0	158,0	M2,5	15.404.40.05.Z/200	30857358
40	6,0	16,0	28,2	49,5	49,5	160,0	37,0	10,0	60,0	119,0	M5	15.404.40.06.Z/160	30816618
40	6,0	16,0	28,2	49,5	49,5	200,0	37,0	10,0	60,0	160,5	M5	15.404.40.06.Z/200	30816625
40	8,0	18,0	28,2	49,5	49,5	160,0	37,0	10,0	50,0	119,5	M6	15.404.40.08.Z/160	30816619
40	8,0	18,0	28,2	49,5	49,5	200,0	37,0	10,0	50,0	160,5	M6	15.404.40.08.Z/200	30816626
40	10,0	20,0	29,2	49,5	49,5	160,0	41,0	10,0	45,0	121,0	M8x1	15.404.40.10.Z/160	30816621
40	10,0	20,0	29,2	49,5	49,5	200,0	41,0	10,0	45,0	162,0	M8x1	15.404.40.10.Z/200	30816628
40	12,0	22,0	30,2	49,5	49,5	160,0	46,0	10,0	40,0	122,0	M10x1	15.404.40.12.Z/160	30816624
40	12,0	22,0	30,2	49,5	49,5	200,0	46,0	10,0	40,0	163,0	M10x1	15.404.40.12.Z/200	30816629
40	14,0	26,0	34,2	49,5	49,5	160,0	46,0	10,0	40,0	121,0	M10x1	15.404.40.14.Z/160	30857258
40	14,0	26,0	34,2	49,5	49,5	200,0	46,0	10,0	40,0	162,0	M10x1	15.404.40.14.Z/200	30857360
40	16,0	28,0	36,2	49,5	49,5	160,0	49,0	10,0	40,0	121,0	M12x1	15.404.40.16.Z/160	30857260
40	16,0	28,0	36,2	49,5	49,5	200,0	49,0	10,0	40,0	162,0	M12x1	15.404.40.16.Z/200	30857362
40	18,0	30,0	36,1	49,5	49,5	160,0	49,0	10,0	30,0	122,0	M12x1	15.404.40.18.Z/160	30857261
40	18,0	30,0	36,1	49,5	49,5	200,0	49,0	10,0	30,0	163,0	M12x1	15.404.40.18.Z/200	30857365
40	20,0	32,0	38,1	49,5	49,5	160,0	51,0	10,0	30,0	122,0	M16x1	15.404.40.20.Z/160	30857263
40	20,0	32,0	38,1	49,5	49,5	200,0	51,0	10,0	30,0	163,0	M16x1	15.404.40.20.Z/200	30857366

Dimensions in mm.

For accessories and spare parts see "Accessories and spare parts" section.

Additional dimensions and special designs available upon request.

High Performance Holder HPH

With axial tool length adjustment

Shank BT according to ISO 7388-2 Form JD/JF (JIS B 6339)

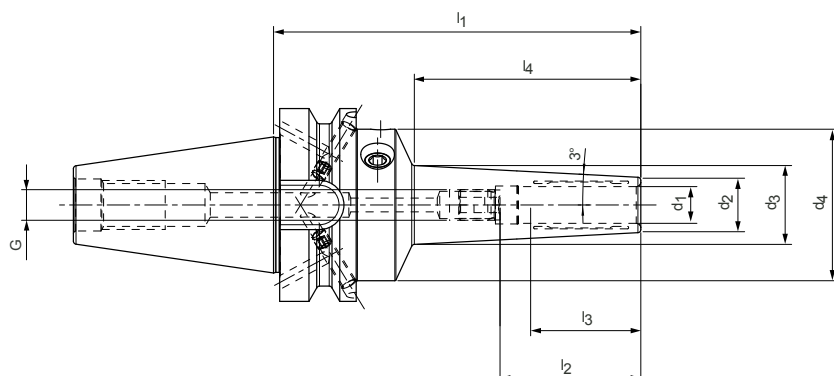

3° slim design | Preferred series available from stock

BT	Dimensions								G	Order designation	Order no.
	d ₁	d ₂	d ₃	d ₄	l ₁	l ₂	l ₃	l ₄			
30*	3,0	10,0	14,8	40,0	85,0	28,0	16,0	45,0	M2,5	22.404.30.03.Z/85	30818761
30*	4,0	12,0	16,8	40,0	85,0	28,0	12,0	45,0	M2,5	22.404.30.04.Z/85	30818762
30*	5,0	13,0	17,8	40,0	85,0	28,0	8,0	45,0	M2,5	22.404.30.05.Z/85	30818763
30*	6,0	14,0	18,9	40,0	85,0	37,0	10,0	46,0	M5	22.404.30.06.Z/85	30818764
30*	8,0	16,0	20,9	40,0	85,0	37,0	10,0	46,0	M6	22.404.30.08.Z/85	30818765
30*	10,0	18,0	23,0	40,0	85,0	41,0	10,0	47,0	M8x1	22.404.30.10.Z/85	30818766
30*	12,0	20,0	25,0	40,0	85,0	46,0	10,0	47,0	M8x1	22.404.30.12.Z/85	30818767
30*	14,0	24,0	29,0	40,0	85,0	46,0	10,0	47,0	M8x1	22.404.30.14.Z/85	30818769
30*	16,0	26,0	31,1	40,0	85,0	49,0	10,0	48,0	M8x1	22.404.30.16.Z/85	30818770
30*	18,0	28,0	33,1	40,0	85,0	49,0	10,0	48,0	M8x1	22.404.30.18.Z/85	30818772
30*	20,0	30,0	35,2	40,0	85,0	51,0	10,0	49,0	M8x1	22.404.30.20.Z/85	30818773
40	3,0	9,0	16,6	49,5	120,0	28,0	16,0	72,0	M2,5	22.404.40.03.Z/120	30777235
40	4,0	10,0	17,6	49,5	120,0	28,0	12,0	72,0	M2,5	22.404.40.04.Z/120	30777237
40	5,0	11,0	18,6	49,5	120,0	28,0	8,0	72,0	M2,5	22.404.40.05.Z/120	30777238
40	6,0	12,0	19,6	49,5	120,0	37,0	10,0	72,0	M5	22.404.40.06.Z/120	30756850
40	8,0	14,0	21,6	49,5	120,0	37,0	10,0	72,0	M6	22.404.40.08.Z/120	30756851
40	10,0	16,0	23,7	49,5	120,0	41,0	10,0	73,0	M8x1	22.404.40.10.Z/120	30756852
40	12,0	18,0	25,8	49,5	120,0	46,0	10,0	74,0	M10x1	22.404.40.12.Z/120	30756853
40	14,0	22,0	29,5	49,5	120,0	46,0	10,0	71,0	M10x1	22.404.40.14.Z/120	30856795
40	16,0	24,0	31,5	49,5	120,0	49,0	10,0	71,0	M12x1	22.404.40.16.Z/120	30856796
40	18,0	26,0	33,6	49,5	120,0	49,0	10,0	72,0	M12x1	22.404.40.18.Z/120	30856797
40	20,0	28,0	35,6	49,5	120,0	51,0	10,0	72,0	M16x1	22.404.40.20.Z/120	30856799

* Design: Taper shank size is not available in the JD/JF combination design

Dimensions in mm.

For accessories and spare parts see "Accessories and spare parts" section.
Additional dimensions and special designs available upon request.

High Performance Holder HPH

With axial tool length adjustment

Shank BT according to ISO 7388-2 Form JD/JF (JIS B 6339)

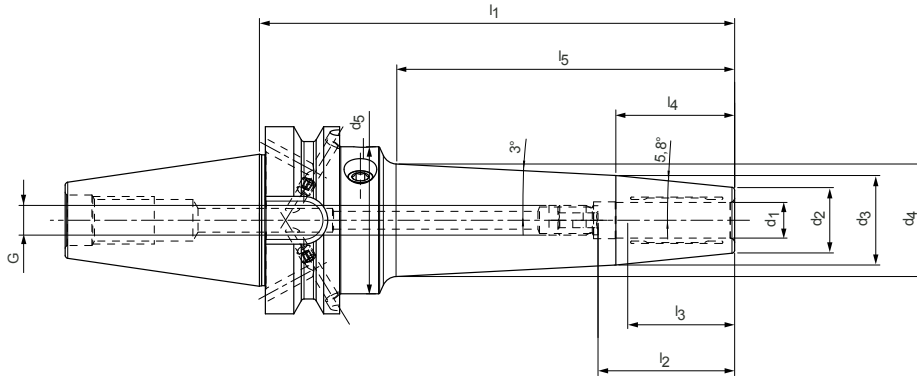

Slim design 3°, optimised contour for maximum bending resistance | Preferred series available from stock

BT	Dimensions								G	Order designation	Order no.
	d_1	d_2	d_3	d_4	l_1	l_2	l_3	l_4			
40	3,0	13,0	31,4	49,5	160,0	28,0	16,0	109,0	M2,5	22.404.40.03.Z/160	30856800
40	3,0	13,0	35,7	49,5	200,0	28,0	16,0	150,0	M2,5	22.404.40.03.Z/200	30857100
40	4,0	14,0	32,4	49,5	160,0	28,0	12,0	109,0	M2,5	22.404.40.04.Z/160	30856801
40	4,0	14,0	36,7	49,5	200,0	28,0	12,0	150,0	M2,5	22.404.40.04.Z/200	30857102
40	5,0	15,0	33,4	49,5	160,0	28,0	8,0	109,0	M2,5	22.404.40.05.Z/160	30856802
40	5,0	15,0	37,7	49,5	200,0	28,0	8,0	150,0	M2,5	22.404.40.05.Z/200	30857104
40	6,0	16,0	33,6	49,5	160,0	37,0	10,0	111,0	M5	22.404.40.06.Z/160	30856803
40	6,0	16,0	37,9	49,5	200,0	37,0	10,0	152,5	M5	22.404.40.06.Z/200	30857105
40	8,0	18,0	34,7	49,5	160,0	37,0	10,0	111,5	M6	22.404.40.08.Z/160	30856804
40	8,0	18,0	39,0	49,5	200,0	37,0	10,0	152,5	M6	22.404.40.08.Z/200	30857106
40	10,0	20,0	36,3	49,5	160,0	41,0	10,0	113,0	M8x1	22.404.40.10.Z/160	30856806
40	10,0	20,0	40,6	49,5	200,0	41,0	10,0	154,0	M8x1	22.404.40.10.Z/200	30857112
40	12,0	22,0	37,9	49,5	160,0	46,0	10,0	114,0	M10x1	22.404.40.12.Z/160	30856808
40	12,0	22,0	42,2	49,5	200,0	46,0	10,0	155,0	M10x1	22.404.40.12.Z/200	30857114
40	14,0	26,0	41,8	49,5	160,0	46,0	10,0	113,0	M10x1	22.404.40.14.Z/160	30856809
40	14,0	26,0	46,1	49,5	200,0	46,0	10,0	154,0	M10x1	22.404.40.14.Z/200	30857116
40	16,0	28,0	43,8	49,5	160,0	49,0	10,0	113,0	M12x1	22.404.40.16.Z/160	30856810
40	16,0	28,0	46,1	49,5	200,0	49,0	10,0	154,0	M12x1	22.404.40.16.Z/200	30857117
40	18,0	30,0	44,9	49,5	160,0	49,0	10,0	114,0	M12x1	22.404.40.18.Z/160	30856811
40	18,0	30,0	47,1	49,5	200,0	49,0	10,0	155,0	M12x1	22.404.40.18.Z/200	30857119
40	20,0	32,0	46,9	49,5	160,0	51,0	10,0	114,0	M16x1	22.404.40.20.Z/160	30856813
40	20,0	32,0	46,9	49,5	200,0	51,0	10,0	155,0	M16x1	22.404.40.20.Z/200	30857120

Dimensions in mm.

For accessories and spare parts see "Accessories and spare parts" section.
Additional dimensions and special designs available upon request.

High Performance Holder HPH

With axial tool length adjustment

Shank similar to ISO 7388-2 Form JD (with face connection)

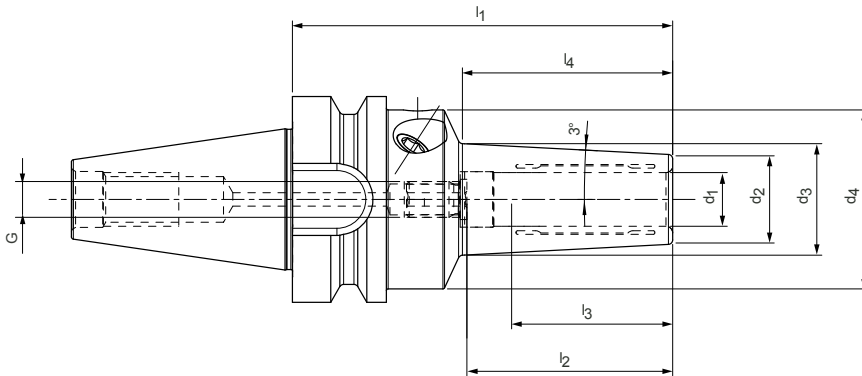

3° slim design | Preferred series available from stock

BT-FC	Dimensions								G	Order designation	Order no.
	d ₁	d ₂	d ₃	d ₄	l ₁	l ₂	l ₃	l ₄			
30	3,0	10,0	14,8	40,0	85,0	28,0	16,0	45,0	M2,5	27.404.30.03.Z/85	30818925
30	4,0	12,0	16,8	40,0	85,0	28,0	12,0	45,0	M2,5	27.404.30.04.Z/85	30818927
30	5,0	13,0	17,8	40,0	85,0	28,0	8,0	45,0	M2,5	27.404.30.05.Z/85	30818930
30	6,0	14,0	18,9	40,0	85,0	37,0	10,0	46,0	M5	27.404.30.06.Z/85	30818932
30	8,0	16,0	20,9	40,0	85,0	37,0	10,0	46,0	M6	27.404.30.08.Z/85	30818934
30	10,0	18,0	23,0	40,0	85,0	41,0	10,0	47,0	M8x1	27.404.30.10.Z/85	30818936
30	12,0	20,0	25,0	40,0	85,0	46,0	10,0	47,0	M8x1	27.404.30.12.Z/85	30818939
30	14,0	24,0	29,0	40,0	85,0	46,0	10,0	47,0	M8x1	27.404.30.14.Z/85	30818941
30	16,0	26,0	31,1	40,0	85,0	49,0	10,0	48,0	M8x1	27.404.30.16.Z/85	30818942
30	18,0	28,0	33,1	40,0	85,0	49,0	10,0	48,0	M8x1	27.404.30.18.Z/85	30818944
30	20,0	30,0	35,2	40,0	85,0	51,0	10,0	49,0	M8x1	27.404.30.20.Z/85	30818947

Dimensions in mm.

For accessories and spare parts see "Accessories and spare parts" section.

Additional dimensions and special designs available upon request.

High Performance Holder HPH

With axial tool length adjustment

HSK-A (hollow shank taper form A) shank according to DIN 69893-1

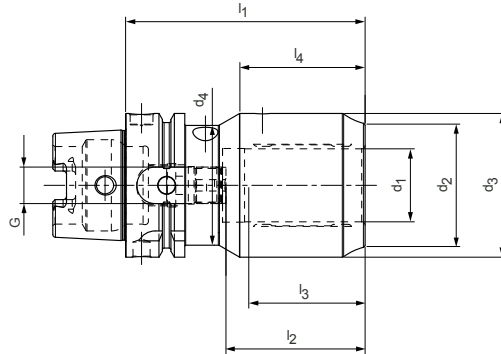
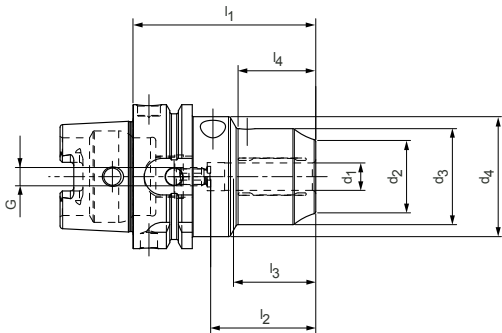

Short heavy-duty design | Preferred series available from stock

HSK-A	Dimensions								G	Order designation	Order no.
	d ₁	d ₂	d ₃	d ₄	l ₁	l ₂	l ₃	l ₄			
63	12,0	32,0	42,0	52,5	80,0	46,0	10,0	34,0	M8x1	16.408.63.12.Z/80	30494132
63	20,0	38,0	49,0	52,5	80,0	51,0	10,0	36,0	M8x1	16.408.63.20.Z/80	30372363
63*	32,0	54,0	63,0	52,5	105,0	61,0	10,0	55,0	M16x1	16.408.63.32.Z/105	30588124
100	12,0	32,0	42,0	52,5	85,0	46,0	10,0	34,0	M8x1	16.408.100.12.Z/85	30515435
100	20,0	38,0	49,0	52,5	85,0	51,0	10,0	36,0	M8x1	16.408.100.20.Z/85	30436113
100	32,0	57,0	68,0	72,0	100,0	61,0	10,0	42,0	M8x1	16.408.100.32.Z/100	30471219

* Hammer head variant, see drawing above right

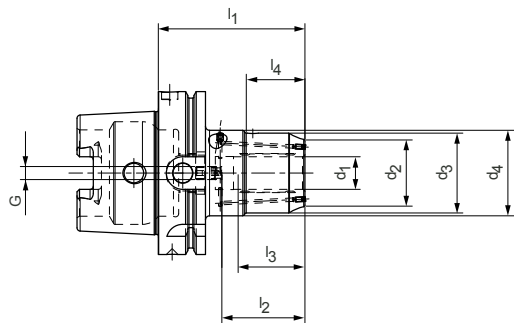

Short heavy-duty design with two coolant outlets, resealable | Preferred series available from stock

HSK-A	Dimensions								G	Order designation	Order no.
	d ₁	d ₂	d ₃	d ₄	l ₁	l ₂	l ₃	l ₄			
63	12,0	32,0	42,0	52,5	80,0	46,0	10,0	34,0	M8x1	16.408.63.12.KKB/80	30565349
63	16,0	38,0	46,0	52,5	80,0	49,0	10,0	35,0	M8x1	16.408.63.16.KKB/80	30565353
63	20,0	41,0	49,0	52,5	80,0	51,0	10,0	36,0	M8x1	16.408.63.20.KKB/80	30565354
100	12,0	32,0	42,0	52,5	90,0	46,0	10,0	34,0	M8x1	16.408.100.12.KKB/90	30967756
100	20,0	41,0	49,0	52,5	90,0	51,0	10,0	36,0	M8x1	16.408.100.20.KKB/90	31038398
100	32,0	57,0	68,0	72,0	105,0	61,0	10,0	42,0	M8x1	16.408.100.32.KKB/105	31038399

Dimensions in mm.

For accessories and spare parts see "Accessories and spare parts" section.
Additional dimensions and special designs available upon request.

High Performance Holder HPH

With axial tool length adjustment

SK shank according to ISO 7388-1 Form AD/AF

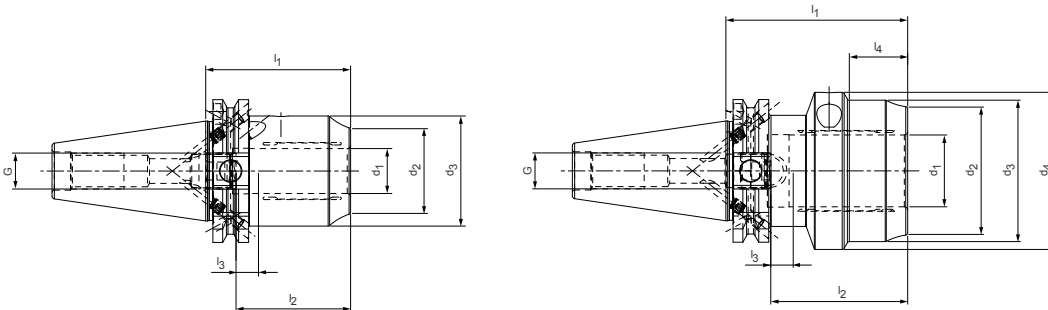

Short heavy-duty design | Preferred series available from stock

Steep taper	Dimensions								G	Order designation	Order no.
	d ₁	d ₂	d ₃	d ₄	l ₁	l ₂	l ₃	l ₄			
40	12,0	32,0	42,0	-	50,0	46,0	10,0	-	M8x1	15.408.40.12.Z/50	30494111
40	20,0	38,0	49,0	-	64,5	51,0	10,0	-	M16x1	15.408.40.20.Z/64.5	30372360
40	32,0	57,0	63,0	70,0	81,0	61,0	10,0	26,0	M16x1	15.408.40.32.Z/81	30986081
50	12,0	32,0	42,0	-	50,0	46,0	10,0	-	M8x1	15.408.50.12.Z/50	30515413
50	20,0	38,0	49,0	-	64,5	51,0	10,0	-	M16x1	15.408.50.20.Z/64.5	30435618
50	32,0	57,0	68,0	72,0	81,0	61,0	10,0	35,0	M16x1	15.408.50.32.Z/81	30471202

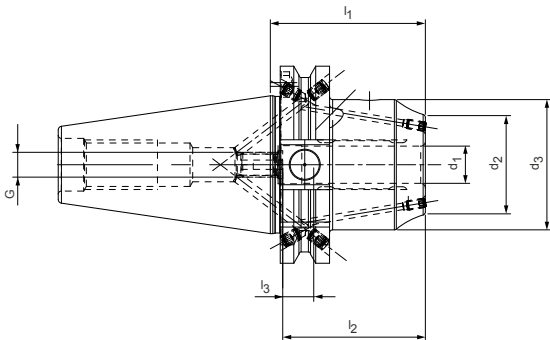

Short heavy-duty design with two coolant outlets, resealable | Preferred series available from stock

Steep taper	Dimensions						G	Order designation	Order no.
	d ₁	d ₂	d ₃	l ₁	l ₂	l ₃			
40	12,0	32,0	42,0	50,0	46,0	10,0	M8x1	15.408.40.12.KKB/50	30565346
40	16,0	38,0	46,0	64,5	49,0	10,0	M12x1	15.408.40.16.KKB/64.5	30565347
40	20,0	41,0	49,0	64,5	51,0	10,0	M16x1	15.408.40.20.KKB/64.5	30565348

Dimensions in mm.

For accessories and spare parts see "Accessories and spare parts" section.
Additional dimensions and special designs available upon request.

High Performance Holder HPH

With axial tool length adjustment

Shank BT according to ISO 7388-2 Form JD/JF (JIS B 6339)

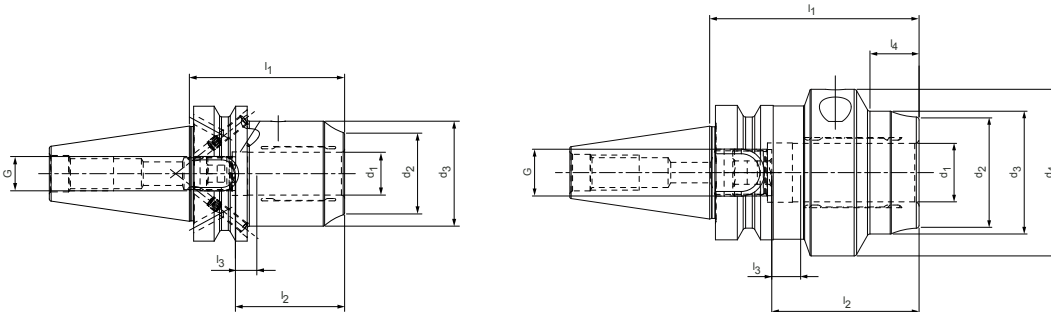

Short heavy-duty design | Preferred series available from stock

BT	Dimensions								G	Order designation	Order no.
	d ₁	d ₂	d ₃	d ₄	l ₁	l ₂	l ₃	l ₄			
30*	12,0	32,0	42,0	-	58,0	46,0	10,0	-	M8x1	22.408.30.12.Z/58	30986082
30*	20,0	38,0	42,0	57,0	72,5	51,0	10,0	17,0	M16x1	22.408.30.20.Z/72,5	30986083
40	12,0	32,0	42,0	-	58,0	46,0	10,0	-	M8x1	22.408.40.12.Z/58	30494128
40	20,0	38,0	49,0	-	72,5	51,0	10,0	-	M16x1	22.408.40.20.Z/72,5	30372364
40	32,0	54,0	63,0	62,0	90,0	61,0	10,0	-	M16x1	22.408.40.32.Z/90	30588119
50	12,0	32,0	42,0	-	69,0	46,0	10,0	-	M8x1	22.408.40.12.Z/69	30515438
50	20,0	38,0	49,0	-	83,5	51,0	10,0	-	M16x1	22.408.40.20.Z/83,5	30435871
50	32,0	57,0	68,0	72,0	90,0	61,0	10,0	35,0	M16x1	22.408.40.32.Z/90	30471206

* Design: Taper shank size is not available in the JD/JF combination design.

Dimensions in mm.

For accessories and spare parts see "Accessories and spare parts" section.
Additional dimensions and special designs available upon request.

High Performance Holder HPH

With axial tool length adjustment

Shank similar to ISO 7388-2 Form JD (with face connection)

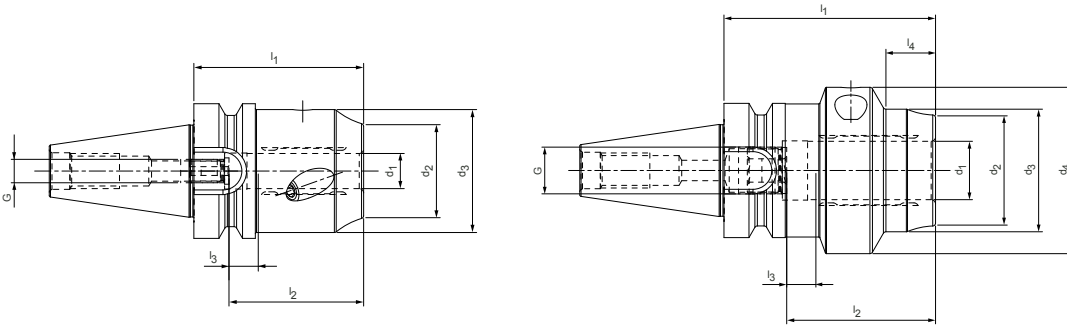

Short heavy-duty design | Preferred series available from stock

BT-FC	Dimensions								G	Order designation	Order no.
	d ₁	d ₂	d ₃	d ₄	l ₁	l ₂	l ₃	l ₄			
30	12,0	32,0	42,0	-	58,0	46,0	10,0	-	M8x1	27.408.30.12.Z/58	30986085
30	20,0	38,0	42,0	57,0	72,5	51,0	10,0	17,0	M16x1	27.408.30.20.Z/72.5	30986086
40	12,0	32,0	42,0	-	58,0	46,0	10,0	-	M8x1	27.408.40.12.Z/58	30970446
40	20,0	38,0	49,0	-	72,5	51,0	10,0	-	M16x1	27.408.40.20.Z/72.5	30717004
40	32,0	54,0	62,0	63,0	90,0	61,0	10,0	48,0	M16x1	27.408.40.32.Z/90	30717007
50	12,0	32,0	42,0	-	69,0	46,0	10,0	-	M8x1	27.408.50.12.Z/69	30970463
50	20,0	38,0	49,0	-	83,5	51,0	10,0	-	M16x1	27.408.50.20.Z/83.5	30970465
50	32,0	57,0	68,0	72,0	90,0	61,0	10,0	35,0	M16x1	27.408.50.32.Z/90	30970466

Dimensions in mm.

For accessories and spare parts see "Accessories and spare parts" section.

Additional dimensions and special designs available upon request.

High Performance Holder HPH

With axial tool length adjustment

Shank hollow shank taper E according to DIN 69893-5

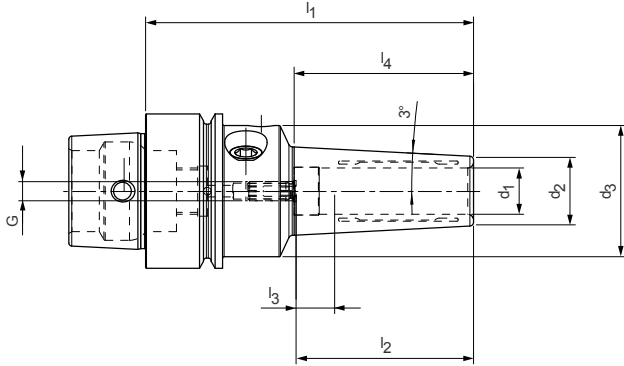

3° slim design | Available upon request

HSK-E	Dimensions							G	Order designation	Order no.
	d ₁	d ₂	d ₃	l ₁	l ₂	l ₃	l ₄			
40	3,0	9,0	34,0	85,0	28,0	16,0	45,0	M2,5	18.404.40.03.Z/85	30817154
40	4,0	10,0	34,0	85,0	28,0	12,0	45,0	M2,5	18.404.40.04.Z/85	30817157
40	5,0	11,0	34,0	85,0	28,0	8,0	45,0	M2,5	18.404.40.05.Z/85	30817158
40	6,0	12,0	34,0	85,0	37,0	10,0	46,0	M5	18.404.40.06.Z/85	30817160
40	8,0	14,0	34,0	85,0	37,0	10,0	46,0	M6	18.404.40.08.Z/85	30817161
40	10,0	16,0	34,0	85,0	41,0	10,0	47,0	M5	18.404.40.10.Z/85	30817162
40	12,0	18,0	34,0	85,0	46,0	10,0	47,0	M5	18.404.40.12.Z/85	30817165
50	3,0	9,0	42,0	85,0	28,0	16,0	37,0	M2,5	18.404.50.03.Z/85	30817167
50	4,0	10,0	42,0	85,0	28,0	12,0	37,0	M2,5	18.404.50.04.Z/85	30817169
50	5,0	11,0	42,0	85,0	28,0	8,0	37,0	M2,5	18.404.50.05.Z/85	30817175
50	6,0	12,0	42,0	85,0	37,0	10,0	38,0	M5	18.404.50.06.Z/85	30817178
50	8,0	14,0	42,0	85,0	37,0	10,0	38,0	M6	18.404.50.08.Z/85	30817181
50	10,0	16,0	42,0	85,0	41,0	10,0	39,0	M8x1	18.404.50.10.Z/85	30817186
50	12,0	18,0	42,0	85,0	46,0	10,0	39,0	M8x1	18.404.50.12.Z/85	30817187

Dimensions in mm.

For accessories and spare parts see "Accessories and spare parts" section.

Additional dimensions and special designs available upon request.

High Performance Holder HPH

With axial tool length adjustment
Shank PSC 6 according to ISO 26623-1

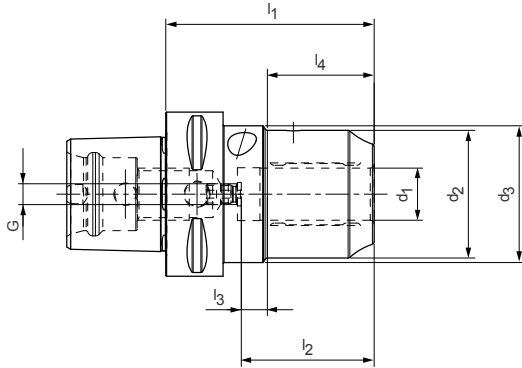

Short heavy-duty design according to ISO 26623-1, IK I Available upon request

PSC	Dimensions							G	Order designation	Order no.
	d_1	d_2	d_3	l_1	l_2	l_3	l_4			
63	20,0	49,0	52,5	80,0	51,0	10,0	41,0	M16x1	67.408.63.20.Z/80	30854987

Dimensions in mm.

For accessories and spare parts see "Accessories and spare parts" section.
Additional dimensions and special designs available upon request.

Hydraulic chuck

With axial tool length adjustment

HSK-A (hollow shank taper form A) shank according to DIN 69893-1

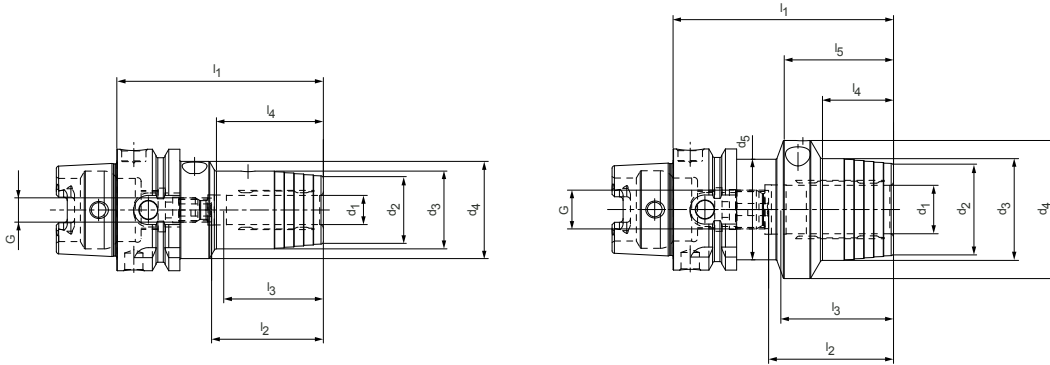

Preferred series available from stock

HSK-A	Dimensions										G	Order designation	Order no.
	d ₁	d ₂	d ₃	d ₄	d ₅	l ₁	l ₂	l ₃	l ₄	l ₅			
32	6,0	22,0	26,0	40,0	-	80,0	37,0	10,0	29,0	-	M5	16.507.32.06.Z/80	30336816
32	8,0	24,0	28,0	40,0	-	80,0	37,0	10,0	29,0	-	M6	16.507.32.08.Z/80	30336817
32	10,0	26,0	30,0	40,0	-	85,0	41,0	10,0	35,0	-	M6	16.507.32.10.Z/85	30336818
32	12,0	28,0	32,0	40,0	-	90,0	46,0	10,0	40,0	-	M6	16.507.32.12.Z/90	30336819
40	6,0	22,0	26,0	33,5	-	70,0	37,0	10,0	36,0	-	M5	16.507.40.06.Z/70	30336820
40	8,0	24,0	28,0	33,5	-	70,0	37,0	10,0	36,0	-	M6	16.507.40.08.Z/70	30336821
40	10,0	26,0	30,0	33,5	-	75,0	41,0	10,0	42,0	-	M6	16.507.40.10.Z/75	30336822
40	12,0	28,0	32,0	33,5	-	80,0	46,0	10,0	48,0	-	M6	16.507.40.12.Z/80	30336823
50	6,0	22,0	26,0	40,0	-	70,0	37,0	10,0	28,0	-	M5	16.507.50.06.Z/70	30336824
50	8,0	24,0	28,0	40,0	-	70,0	37,0	10,0	28,0	-	M6	16.507.50.08.Z/70	30336825
50	10,0	26,0	30,0	40,0	-	75,0	41,0	10,0	34,0	-	M8x1	16.507.50.10.Z/75	30336826
50	12,0	28,0	32,0	40,0	-	85,0	46,0	10,0	44,0	-	M10x1	16.507.50.12.Z/85	30336827
50	14,0	30,0	34,0	40,0	-	85,0	46,0	10,0	44,0	-	M10x1	16.507.50.14.Z/85	30336828
50	16,0	34,0	38,0	53,0	41,5	90,0	49,0	10,0	30,0	45,5	M12x1	16.507.50.16.Z/90	30336829
50	18,0	36,0	40,0	53,0	41,5	90,0	49,0	10,0	30,0	45,5	M12x1	16.507.50.18.Z/90	30336830
50	20,0	38,0	42,0	57,0	41,5	90,0	51,0	10,0	29,0	45,5	M16x1	16.507.50.20.Z/90	30336831
63	6,0	22,0	26,0	50,0	-	70,0	37,0	10,0	24,0	-	M5	16.507.63.06.Z/70	30336832
63	6,0	22,0	26,0	50,0	-	120,0	37,0	10,0	73,0	-	M5	16.507.63.06.Z/120	30336834
63	6,0	22,0	26,0	50,0	-	150,0	37,0	10,0	103,0	-	M5	16.507.63.06.Z/150	30336835
63	6,0	22,0	26,0	50,0	-	200,0	37,0	10,0	153,0	-	M5	16.507.63.06.Z/200	30336836
63	8,0	24,0	28,0	50,0	-	70,0	37,0	10,0	25,0	-	M6	16.507.63.08.Z/70	30336837
63	8,0	24,0	28,0	50,0	-	120,0	37,0	10,0	74,0	-	M6	16.507.63.08.Z/120	30336839
63	8,0	24,0	28,0	50,0	-	150,0	37,0	10,0	104,0	-	M6	16.507.63.08.Z/150	30336840
63	8,0	24,0	28,0	50,0	-	200,0	37,0	10,0	154,0	-	M6	16.507.63.08.Z/200	30336841
63	10,0	26,0	30,0	50,0	-	80,0	41,0	10,0	35,0	-	M8x1	16.507.63.10.Z/80	30336842
63	10,0	26,0	30,0	50,0	-	120,0	41,0	10,0	74,0	-	M8x1	16.507.63.10.Z/120	30336844
63	10,0	26,0	30,0	50,0	-	150,0	41,0	10,0	104,0	-	M8x1	16.507.63.10.Z/150	30336845
63	10,0	26,0	30,0	50,0	-	200,0	41,0	10,0	154,0	-	M8x1	16.507.63.10.Z/200	30336846
63	12,0	28,0	32,0	50,0	-	85,0	46,0	10,0	40,0	-	M10x1	16.507.63.12.Z/85	30336847
63	12,0	28,0	32,0	50,0	-	120,0	46,0	10,0	75,0	-	M10x1	16.507.63.12.Z/120	30336849
63	12,0	28,0	32,0	50,0	-	150,0	46,0	10,0	105,0	-	M10x1	16.507.63.12.Z/150	30336850
63	12,0	28,0	32,0	50,0	-	200,0	46,0	10,0	155,0	-	M10x1	16.507.63.12.Z/200	30336851
63	14,0	30,0	34,0	50,0	-	85,0	46,0	10,0	40,0	-	M10x1	16.507.63.14.Z/85	30336852
63	14,0	30,0	34,0	50,0	-	120,0	46,0	10,0	75,0	-	M10x1	16.507.63.14.Z/120	30336854
63	14,0	30,0	34,0	50,0	-	150,0	46,0	10,0	105,0	-	M10x1	16.507.63.14.Z/150	30336855
63	14,0	30,0	34,0	50,0	-	200,0	46,0	10,0	155,0	-	M10x1	16.507.63.14.Z/200	30336856
63	16,0	34,0	38,0	50,0	-	90,0	49,0	10,0	46,0	-	M12x1	16.507.63.16.Z/90	30336857
63	16,0	34,0	38,0	50,0	-	120,0	49,0	10,0	76,0	-	M12x1	16.507.63.16.Z/120	30336859
63	16,0	34,0	38,0	50,0	-	150,0	49,0	10,0	106,0	-	M12x1	16.507.63.16.Z/150	30336860

Preferred series available from stock

HSK-A	Dimensions										G	Order designation	Order no.
	d ₁	d ₂	d ₃	d ₄	d ₅	l ₁	l ₂	l ₃	l ₄	l ₅			
63	16,0	34,0	38,0	50,0	-	200,0	49,0	10,0	156,0	-	M12x1	16.507.63.16.Z/200	30336861
63	18,0	36,0	40,0	50,0	-	90,0	49,0	10,0	47,0	-	M12x1	16.507.63.18.Z/90	30336862
63	18,0	36,0	40,0	50,0	-	120,0	49,0	10,0	77,0	-	M12x1	16.507.63.18.Z/120	30336864
63	18,0	36,0	40,0	50,0	-	150,0	49,0	10,0	107,0	-	M12x1	16.507.63.18.Z/150	30336865
63	18,0	36,0	40,0	50,0	-	200,0	49,0	10,0	157,0	-	M12x1	16.507.63.18.Z/200	30336866
63	20,0	38,0	42,0	50,0	-	90,0	51,0	10,0	48,0	-	M16x1	16.507.63.20.Z/90	30336867
63	20,0	38,0	42,0	50,0	-	120,0	51,0	10,0	78,0	-	M16x1	16.507.63.20.Z/120	30336870
63	20,0	38,0	42,0	50,0	-	150,0	51,0	10,0	108,0	-	M16x1	16.507.63.20.Z/150	30336871
63	20,0	38,0	42,0	50,0	-	200,0	51,0	10,0	158,0	-	M16x1	16.507.63.20.Z/200	30336872
63	25,0	53,0	57,0	52,5	-	120,0	57,0	10,0	63,0	-	M16x1	16.507.63.25.Z/120	30336873
63	25,0	53,0	57,0	52,5	-	150,0	57,0	10,0	63,0	-	M16x1	16.507.63.25.Z/150	30784759
63	25,0	53,0	57,0	52,5	-	200,0	57,0	10,0	63,0	-	M16x1	16.507.63.25.Z/200	30877963
63	32,0	59,0	63,0	59,0	52,5	125,0	61,0	10,0	61,0	77,0	M16x1	16.507.63.32.Z/125	30336875
63	32,0	59,0	63,0	59,0	52,5	150,0	61,0	10,0	65,0	77,0	M16x1	16.507.63.32.Z/150	30877971
63	32,0	59,0	63,0	59,0	52,2	200,0	61,0	10,0	65,0	77,0	M16x1	16.507.63.32.Z/200	30877974
80	6,0	22,0	26,0	50,0	-	70,0	37,0	10,0	24,0	-	M5	16.507.80.06.Z/70	30432279
80	8,0	24,0	28,0	50,0	-	70,0	37,0	10,0	24,0	-	M6	16.507.80.08.Z/70	30432282
80	10,0	26,0	30,0	50,0	-	80,0	41,0	10,0	35,0	-	M8x1	16.507.80.10.Z/80	30432285
80	12,0	28,0	32,0	50,0	-	85,0	46,0	10,0	40,0	-	M10x1	16.507.80.12.Z/85	30432287
80	14,0	30,0	34,0	50,0	-	85,0	46,0	10,0	40,0	-	M10x1	16.507.80.14.Z/85	30432288
80	16,0	34,0	38,0	50,0	-	95,0	49,0	10,0	51,0	-	M12x1	16.507.80.16.Z/95	30409104
80	18,0	36,0	40,0	50,0	-	95,0	49,0	10,0	51,0	-	M12x1	16.507.80.18.Z/95	30432290
80	20,0	38,0	42,0	50,0	-	95,0	51,0	10,0	51,0	-	M16x1	16.507.80.20.Z/95	30432292
80	25,0	53,0	57,0	63,0	-	110,0	57,0	10,0	65,0	-	M16x1	16.507.80.25.Z/110	30432295
80	32,0	59,0	63,0	66,5	-	125,0	61,0	10,0	63,0	-	M16x1	16.507.80.32.Z/125	30432301
100	6,0	22,0	26,0	50,0	-	75,0	37,0	10,0	26,0	-	M5	16.507.100.06.Z/75	30336784
100	6,0	22,0	26,0	50,0	-	120,0	37,0	10,0	71,0	-	M5	16.507.100.06.Z/120	30336786
100	8,0	24,0	28,0	50,0	-	75,0	37,0	10,0	26,0	-	M6	16.507.100.08.Z/75	30336788
100	8,0	24,0	28,0	50,0	-	120,0	37,0	10,0	71,0	-	M6	16.507.100.08.Z/120	30336790
100	10,0	26,0	30,0	50,0	-	90,0	41,0	10,0	42,0	-	M8x1	16.507.100.10.Z/90	30336792
100	10,0	26,0	30,0	50,0	-	120,0	41,0	10,0	72,0	-	M8x1	16.507.100.10.Z/120	30336794
100	12,0	28,0	32,0	50,0	-	95,0	46,0	10,0	47,0	-	M10x1	16.507.100.12.Z/95	30336796
100	12,0	28,0	32,0	50,0	-	120,0	46,0	10,0	72,0	-	M10x1	16.507.100.12.Z/120	30336798
100	14,0	30,0	34,0	50,0	-	95,0	46,0	10,0	47,0	-	M10x1	16.507.100.14.Z/95	30336800
100	16,0	34,0	38,0	50,0	-	100,0	49,0	10,0	53,0	-	M12x1	16.507.100.16.Z/100	30336802
100	18,0	36,0	40,0	50,0	-	100,0	49,0	10,0	53,0	-	M12x1	16.507.100.18.Z/100	30336806
100	20,0	38,0	42,0	50,0	-	105,0	51,0	10,0	59,0	-	M16x1	16.507.100.20.Z/105	30336808
100	25,0	53,0	57,0	63,0	-	110,0	57,0	10,0	62,0	-	M16x1	16.507.100.25.Z/110	30336812
100	32,0	59,0	63,0	67,0	-	110,0	61,0	10,0	62,0	-	M16x1	16.507.100.32.Z/110	30336814

Dimensions in mm.

For accessories and spare parts see "Accessories and spare parts" section.

Additional dimensions and special designs available upon request.

Hydraulic chuck

With axial tool length adjustment

SK shank according to ISO 7388-1 Form AD/AF

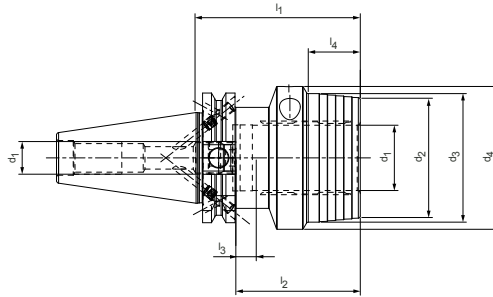
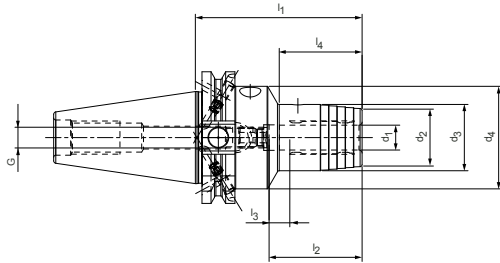

Preferred series available from stock

Steep taper	Dimensions										G	Order designation	Order no.
	d ₁	d ₂	d ₃	d ₄	d ₅	l ₁	l ₂	l ₃	l ₄	l ₅			
30*	6,0	23,0	26,0	44,5	-	55,0	37,0	10,0	20,0	-	M5	15.507.30.06.Z/55	30336701
30*	8,0	24,0	28,0	44,5	-	55,0	37,0	10,0	20,0	-	M6	15.507.30.08.Z/55	30336702
30*	10,0	27,0	30,0	44,5	-	55,0	41,0	10,0	21,0	-	M8x1	15.507.30.10.Z/55	30336703
30*	12,0	28,0	32,0	44,5	-	55,0	46,0	10,0	22,0	-	M8x1	15.507.30.12.Z/55	30336704
30*	14,0	30,0	34,0	44,5	-	90,0	46,0	10,0	42,0	-	M8x1	15.507.30.14.Z/90	30336705
30*	16,0	34,0	38,0	44,5	-	90,0	49,0	10,0	50,0	-	M8x1	15.507.30.16.Z/90	30336706
30*	18,0	36,0	40,0	44,5	-	90,0	49,0	10,0	50,0	-	M8x1	15.507.30.18.Z/90	30336707
30*	20,0	38,0	42,0	44,5	-	90,0	51,0	10,0	50,0	-	M8x1	15.507.30.20.Z/90	30336708
40	6,0	22,0	26,0	49,5	-	80,5	37,0	10,0	29,5	-	M5	15.507.40.06.Z/80.5	30336709
40	8,0	24,0	28,0	49,5	-	80,5	37,0	10,0	30,0	-	M6	15.507.40.08.Z/80.5	30336712
40	10,0	26,0	30,0	49,5	-	80,5	41,0	10,0	35,0	-	M8x1	15.507.40.10.Z/80.5	30336715
40	12,0	28,0	32,0	49,5	-	80,5	46,0	10,0	40,0	-	M10x1	15.507.40.12.Z/80.5	30336719
40	14,0	30,0	34,0	49,5	-	80,5	46,0	10,0	40,0	-	M10x1	15.507.40.14.Z/80.5	30336723
40	16,0	34,0	38,0	49,5	-	80,5	49,0	10,0	45,0	-	M12x1	15.507.40.16.Z/80.5	30336726
40	18,0	36,0	40,0	49,5	-	80,5	49,0	10,0	46,0	-	M12x1	15.507.40.18.Z/80.5	30336729
40	20,0	38,0	42,0	49,5	-	80,5	51,0	10,0	47,0	-	M16x1	15.507.40.20.Z/80.5	30336732
40	25,0	51,0	55,0	63,0	49,5	80,5	57,0	10,0	28,0	42,0	M16x1	15.507.40.25.Z/80.5	30336736
40	32,0	59,0	63,0	70,0	49,5	80,5	61,0	10,0	20,0	41,0	M16x1	15.507.40.32.Z/80.5	30336739
50	6,0	22,0	26,0	49,5	-	80,5	37,0	10,0	29,5	-	M5	15.507.50.06.Z/80.5	30336743
50	8,0	24,0	28,0	49,5	-	80,5	37,0	10,0	30,0	-	M6	15.507.50.08.Z/80.5	30336746
50	10,0	26,0	30,0	49,5	-	80,5	41,0	10,0	35,0	-	M8x1	15.507.50.10.Z/80.5	30336749
50	12,0	28,0	32,0	49,5	-	80,5	46,0	10,0	40,0	-	M10x1	15.507.50.12.Z/80.5	30336752
50	14,0	30,0	34,0	49,5	-	80,5	46,0	10,0	40,0	-	M10x1	15.507.50.14.Z/80.5	30336755
50	16,0	34,0	38,0	49,5	-	80,5	49,0	10,0	45,0	-	M12x1	15.507.50.16.Z/80.5	30336758
50	18,0	36,0	40,0	49,5	-	80,5	49,0	10,0	46,0	-	M12x1	15.507.50.18.Z/80.5	30336761
50	20,0	38,0	42,0	49,5	-	80,5	51,0	10,0	42,0	-	M16x1	15.507.50.20.Z/80.5	30336764
50	25,0	51,0	55,0	63,0	-	100,0	57,0	10,0	48,0	-	M16x1	15.507.50.25.Z/100	30336767
50	32,0	59,0	63,0	70,0	-	100,0	61,0	10,0	61,0	-	M16x1	15.507.50.32.Z/100	30336770

* Design: Taper shank size is not available in the AD/AF combination design

Dimensions in mm.

For accessories and spare parts see "Accessories and spare parts" section.
Additional dimensions and special designs available upon request.

Hydraulic chuck

With axial tool length adjustment

Shank BT according to ISO 7388-2 Form JD/JF (JIS B 6339)

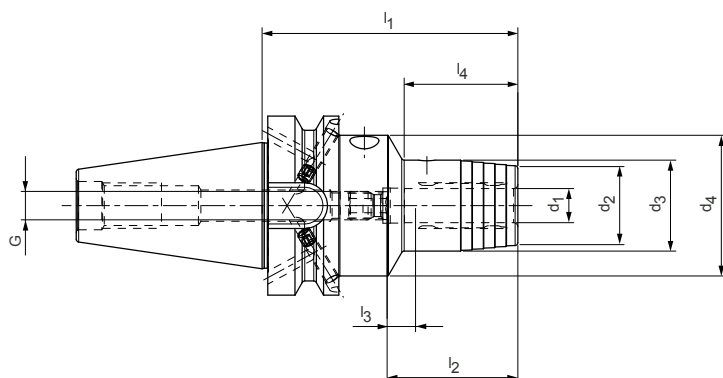

Preferred series available from stock

BT	Dimensions								G	Order designation	Order no.
	d ₁	d ₂	d ₃	d ₄	l ₁	l ₂	l ₃	l ₄			
30*	6,0	23,0	26,0	45,0	50,8	37,0	10,0	12,3	M5	22.507.30.06.Z/50.8	30336900
30*	8,0	25,0	28,0	45,0	50,8	37,0	10,0	12,5	M6	22.507.30.08.Z/50.8	30336905
30*	10,0	27,0	30,0	45,0	50,8	41,0	10,0	13,0	M8x1	22.507.30.10.Z/50.8	30336910
30*	12,0	29,0	32,0	45,0	50,8	46,0	10,0	14,0	M8x1	22.507.30.12.Z/50.8	30336915
30*	14,0	30,0	34,0	45,0	90,0	46,0	10,0	45,0	M8x1	22.507.30.14.Z/90	30336920
30*	16,0	34,0	38,0	45,0	90,0	49,0	10,0	50,0	M8x1	22.507.30.16.Z/90	30336921
30*	18,0	36,0	40,0	45,0	90,0	49,0	10,0	50,0	M8x1	22.507.30.18.Z/90	30336924
30*	20,0	38,0	42,0	45,0	90,0	51,0	10,0	50,0	M8x1	22.507.30.20.Z/90	30336925
40	6,0	22,0	26,0	49,5	90,0	37,0	10,0	29,0	M5	22.507.40.06.Z/90	30336927
40	8,0	24,0	28,0	49,5	90,0	37,0	10,0	30,0	M6	22.507.40.08.Z/90	30336933
40	10,0	26,0	30,0	49,5	90,0	41,0	10,0	35,0	M8x1	22.507.40.10.Z/90	30336939
40	12,0	28,0	32,0	49,5	90,0	46,0	10,0	40,0	M10x1	22.507.40.12.Z/90	30336946
40	14,0	30,0	34,0	49,5	90,0	46,0	10,0	40,0	M10x1	22.507.40.14.Z/90	30336953
40	16,0	34,0	38,0	49,5	90,0	49,0	10,0	45,0	M12x1	22.507.40.16.Z/90	30336958
40	18,0	36,0	40,0	49,5	90,0	49,0	10,0	46,0	M12x1	22.507.40.18.Z/90	30336964
40	20,0	38,0	42,0	49,5	90,0	51,0	10,0	47,0	M16x1	22.507.40.20.Z/90	30336969
40	25,0	51,0	55,0	52,0	90,0	57,0	10,0	50,0	M16x1	22.507.40.25.Z/90	30336975
40	32,0	59,0	63,0	62,0	90,0	61,0	10,0	48,0	M16x1	22.507.40.32.Z/90	30336982
50	6,0	22,0	26,0	49,5	90,0	37,0	10,0	29,0	M5	22.507.50.06.Z/90	30336989
50	8,0	24,0	28,0	49,5	90,0	37,0	10,0	30,0	M6	22.507.50.08.Z/90	30336995
50	10,0	26,0	30,0	49,5	90,0	41,0	10,0	34,0	M8x1	22.507.50.10.Z/90	30337001
50	12,0	28,0	32,0	49,5	90,0	46,0	10,0	34,0	M10x1	22.507.50.12.Z/90	30337007
50	14,0	30,0	34,0	49,5	90,0	46,0	10,0	35,0	M10x1	22.507.50.14.Z/90	30337013
50	16,0	34,0	38,0	49,5	90,0	49,0	10,0	35,0	M12x1	22.507.50.16.Z/90	30337017
50	18,0	36,0	40,0	49,5	90,0	49,0	10,0	35,0	M12x1	22.507.50.18.Z/90	30337023
50	20,0	38,0	42,0	49,5	90,0	51,0	10,0	35,0	M16x1	22.507.50.20.Z/90	30337027
50	25,0	51,0	55,0	63,0	110,0	57,0	10,0	48,0	M16x1	22.507.50.25.Z/110	30337033
50	32,0	59,0	63,0	70,0	110,0	61,0	10,0	50,0	M16x1	22.507.50.32.Z/110	30337039

* Design: Taper shank size is not available in the JD/JF combination design

Dimensions in mm.

For accessories and spare parts see "Accessories and spare parts" section.
Additional dimensions and special designs available upon request.

Hydraulic chuck

With radial and angular alignment and axial tool length adjustment
Module connection sizes in accordance with MN5000-14

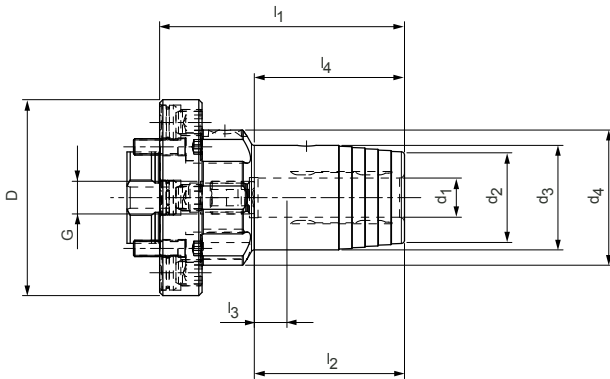

Preferred series available from stock

Mounting diameter Module D	Dimensions								G	Order designation	Order no.
	d ₁	d ₂	d ₃	d ₄	l ₁	l ₂	l ₃	l ₄			
60	6,0	22,0	26,0	42,0	65,0	37,0	10,0	34,0	M5	68.507.60.06.Z/65	30716685
60	8,0	24,0	28,0	42,0	65,0	37,0	10,0	35,0	M6	68.507.60.08.Z/65	30716687
60	10,0	26,0	30,0	42,0	70,0	41,0	10,0	40,0	M8x1	68.507.60.10.Z/70	30716688
60	12,0	28,0	32,0	42,0	75,0	46,0	10,0	46,0	M10x1	68.507.60.12.Z/75	30716691
80	12,0	28,0	32,0	50,0	77,5	46,0	10,0	41,5	M10x1	68.507.80.12.Z/77.5	30338153
80	16,0	34,0	38,0	50,0	82,5	49,0	10,0	47,5	M12x1	68.507.80.16.Z/82.5	30338154
80	20,0	38,0	42,0	50,0	82,5	51,0	10,0	50,0	M16x1	68.507.80.20.Z/82.5	30338155
100	25,0	53,0	57,0	63,0	100,0	57,0	10,0	61,0	M16x1	68.507.100.25.Z/100	30492397
117	32,0	60,0	64,0	75,0	103,0	61,0	10,0	61,0	M16x1	68.507.117.32.Z/103	30492399

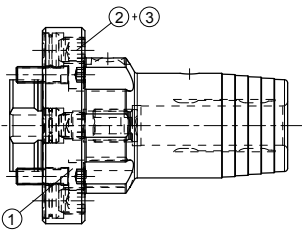

Spare parts for HydroChuck hydraulic chuck with radial and angular alignment

Module diameter D	Quantity required	① Cylinder head screw in accordance with ISO 4762		② Thrust pad		③ Threaded pin	
		Size	Order no.	Order designation	Order no.	Order designation	Order no.
60	4	M5x16 - 12.9	10003601	ø10.6x5	10040108	M8x1x8	10040109
80	4	M6x20 - 12.9	10003619	ø10.6x5	10040108	M8x1x11.5	10075074
100	4	M8x25 - 12.9	10003637	ø12.8x5	10075116	M10x1x14	10075100
117	4	M8x25 - 12.9	10003637	ø12.8x5	10075116	M10x1x14	10075100

Dimensions in mm.

For accessories and spare parts see "Accessories and spare parts" section.
Additional dimensions and special designs available upon request.

Hydraulic chuck

In accordance with DIN 69882-7 with radial tool length adjustment
HSK-A (hollow shank taper form A) shank according to DIN 69893-1

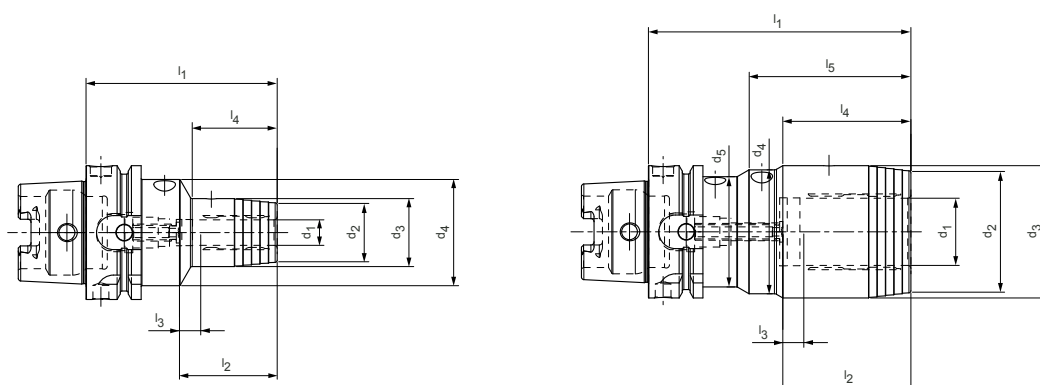

Preferred series available from stock

HSK-A	Dimensions										G	Order designation	Order no.
	d ₁	d ₂	d ₃	d ₄	d ₅	l ₁	l ₂	l ₃	l ₄	l ₅			
63	6,0	22,0	26,0	50,0	-	80,0	37,0	10,0	33,0	-	M6	16.510.63.06.Z/80	30349340
63	8,0	24,0	28,0	50,0	-	80,0	37,0	10,0	33,0	-	M6	16.510.63.08.Z/80	30349342
63	10,0	26,0	30,0	50,0	-	85,0	41,0	10,0	38,0	-	M8x1	16.510.63.10.Z/85	30349343
63	12,0	28,0	32,0	50,0	-	90,0	46,0	10,0	40,0	-	M8x1	16.510.63.12.Z/90	30349344
63	14,0	30,0	34,0	50,0	-	90,0	46,0	10,0	46,0	-	M8x1	16.510.63.14.Z/90	30349345
63	16,0	34,0	38,0	50,0	-	95,0	49,0	10,0	51,0	-	M8x1	16.510.63.16.Z/95	30349346
63	18,0	36,0	40,0	50,0	-	95,0	49,0	10,0	52,0	-	M8x1	16.510.63.18.Z/95	30349347
63	20,0	38,0	42,0	50,0	-	100,0	51,0	10,0	51,0	-	M8x1	16.510.63.20.Z/100	30349348
63	25,0	53,0	57,0	52,5	-	120,0	57,0	10,0	54,5	-	M8x1	16.510.63.25.Z/120	30349349
63	32,0	58,0	63,0	59,0	52,5	125,0	61,0	10,0	61,0	77,0	M8x1	16.510.63.32.Z/125	30349350
100	6,0	22,0	26,0	63,0	-	85,0	37,0	10,0	33,0	-	M6	16.510.100.06.Z/85	30349351
100	8,0	24,0	28,0	63,0	-	85,0	37,0	10,0	33,0	-	M6	16.510.100.08.Z/85	30349352
100	10,0	26,0	30,0	63,0	-	90,0	41,0	10,0	36,0	-	M8x1	16.510.100.10.Z/90	30349353
100	12,0	28,0	32,0	63,0	-	95,0	46,0	10,0	40,0	-	M8x1	16.510.100.12.Z/95	30349354
100	14,0	30,0	34,0	63,0	-	95,0	46,0	10,0	41,0	-	M8x1	16.510.100.14.Z/95	30349355
100	16,0	34,0	38,0	63,0	-	100,0	49,0	10,0	46,0	-	M8x1	16.510.100.16.Z/100	30349356
100	18,0	36,0	40,0	63,0	-	100,0	49,0	10,0	46,0	-	M8x1	16.510.100.18.Z/100	30349357
100	20,0	38,0	42,0	75,0	-	105,0	51,0	10,0	51,0	-	M8x1	16.510.100.20.Z/105	30349358
100	25,0	53,0	57,0	75,0	-	115,0	57,0	10,0	55,5	-	M8x1	16.510.100.25.Z/115	30349359
100	32,0	58,0	63,0	75,0	-	120,0	61,0	10,0	63,5	-	M8x1	16.510.100.32.Z/120	30349360

Dimensions in mm.

For accessories and spare parts see "Accessories and spare parts" section.
Additional dimensions and special designs available upon request.

Hydraulic chuck

With axial tool length adjustment

SK shank according to ISO 7388-1 Form AD/AF

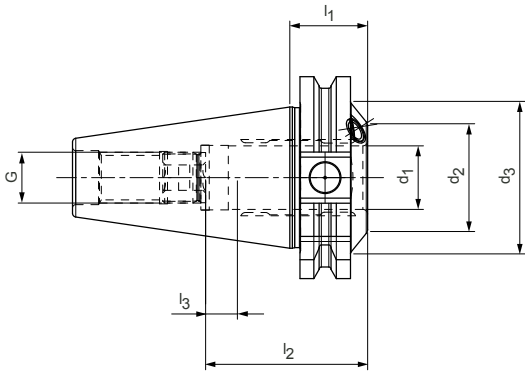

Ultra-short design | Preferred series available from stock

Steep taper	Dimensions						G	Order designation	Order no.
	d ₁	d ₂	d ₃	l ₁	l ₂	l ₃			
40	20,0	34,0	48,0	24,5	51,0	10,0	M16x1	15.501.40.20.Z/24.5	30349264

Dimensions in mm.

For accessories and spare parts see "Accessories and spare parts" section.
Additional dimensions and special designs available upon request.

Hydraulic chuck

With axial tool length adjustment

Shank BT according to ISO 7388-2 Form JD (JIS B 6339)

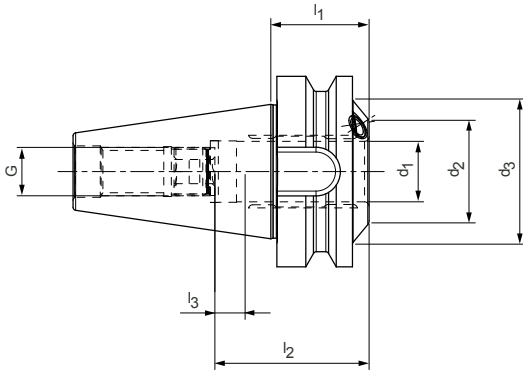

Ultra-short design | Preferred series available from stock

BT	Dimensions						G	Order designation	Order no.
	d_1	d_2	d_3	l_1	l_2	l_3			
40	20,0	38,0	48,0	32,5	51,0	10,0	M16x1	22.501.40.20.Z/32.5	30411484

Dimensions in mm.

For accessories and spare parts see "Accessories and spare parts" section.
Additional dimensions and special designs available upon request.

Hydraulic compensation chuck

With axial tool length adjustment and radial alignment feature
 HSK-A (hollow shank taper form A) shank according to DIN 69893-1

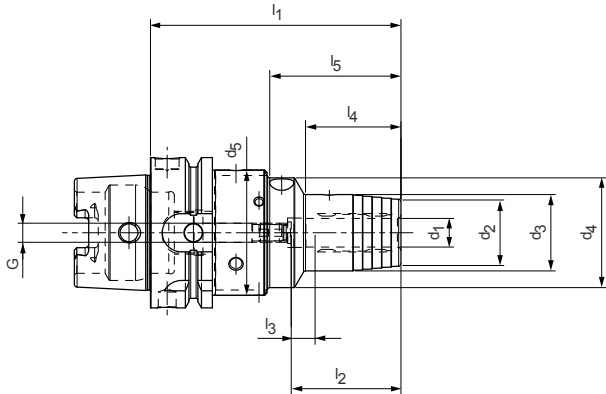

Preferred series available from stock

HSK-A	Dimensions										G	Order designation	Order no.
	d_1	d_2	d_3	d_4	d_5	l_1	l_2	l_3	l_4	l_5			
63	12,0	28,0	32,0	46,0	52,5	105,0	46,0	10,0	40,0	55,0	M8x1	16.512.63.12.Z/105	30614752
63	16,0	34,0	38,0	46,0	52,5	110,0	49,0	10,0	45,0	60,0	M8x1	16.512.63.16.Z/110	30614764
63	20,0	38,0	42,0	46,0	52,5	115,0	51,0	10,0	50,0	65,0	M8x1	16.512.63.20.Z/115	30614765
63	25,0	53,0	57,0	64,0	70,0	145,0	57,0	10,0	55,0	69,5	M16x1	16.512.63.25.Z/145	30614766
63	32,0	59,0	63,0	64,0	70,0	150,0	61,0	10,0	60,0	74,5	M16x1	16.512.63.32.Z/150	30614767
100	12,0	28,0	32,0	46,0	52,5	110,0	46,0	10,0	40,0	55,0	M8x1	16.512.63.12.Z/110	30870743
100	16,0	34,0	38,0	46,0	52,5	115,0	49,0	10,0	45,0	60,0	M8x1	16.512.63.16.Z/115	30870747
100	20,0	38,0	42,0	46,0	52,5	120,0	51,0	10,0	50,0	65,0	M8x1	16.512.63.20.Z/120	30870749
100	25,0	53,0	57,0	64,0	70,0	130,0	57,0	10,0	55,0	69,5	M16x1	16.512.63.25.Z/130	30870751
100	32,0	59,0	63,0	64,0	70,0	135,0	61,0	10,0	60,0	74,5	M16x1	16.512.63.32.Z/135	30870752

Dimensions in mm.

For accessories and spare parts see "Accessories and spare parts" section.
 Additional dimensions and special designs available upon request.

Hydraulic compensation chuck

With axial tool length adjustment and radial alignment feature
SK shank according to ISO 7388-1 Form AD/AF

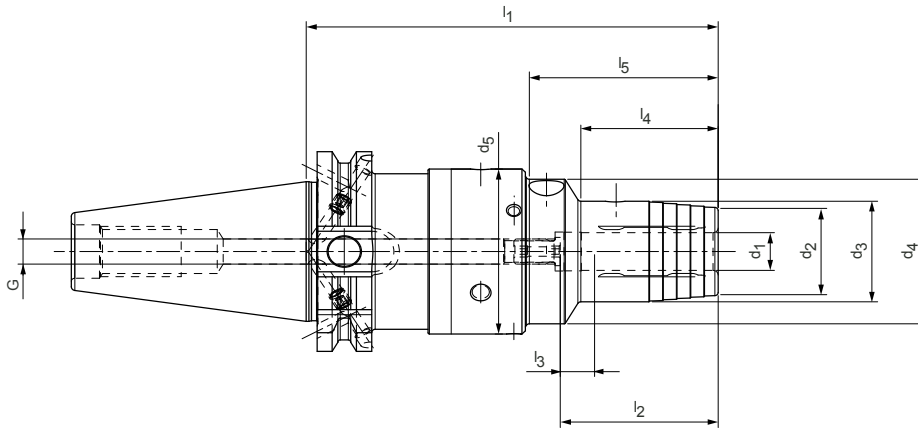

Preferred series available from stock

Steep taper	Dimensions										G	Order designation	Order no.
	d_1	d_2	d_3	d_4	d_5	l_1	l_2	l_3	l_4	l_5			
40	12,0	28,0	32,0	46,0	52,5	120,0	46,0	10,0	40,0	55,0	M8x1	15.512.40.12.Z/120	30870714
40	16,0	34,0	38,0	46,0	52,5	125,0	49,0	10,0	45,0	60,0	M8x1	15.512.40.16.Z/125	30870718
40	20,0	38,0	42,0	46,0	52,5	130,0	51,0	10,0	50,0	65,0	M8x1	15.512.40.20.Z/130	30870735
40	25,0	53,0	57,0	64,0	70,0	140,0	57,0	10,0	55,0	69,5	M16x1	15.512.40.25.Z/140	30870739
40	32,0	59,0	63,0	64,0	70,0	145,0	61,0	10,0	60,0	74,5	M16x1	15.512.40.32.Z/145	30870741
50	12,0	28,0	32,0	46,0	52,5	100,0	46,0	10,0	40,0	55,0	M8x1	15.512.50.12.Z/100	30870707
50	16,0	34,0	38,0	46,0	52,5	105,0	49,0	10,0	45,0	60,0	M8x1	15.512.50.16.Z/105	30870708
50	20,0	38,0	42,0	46,0	52,5	110,0	51,0	10,0	50,0	65,0	M8x1	15.512.50.20.Z/110	30614768
50	25,0	53,0	57,0	64,0	70,0	115,0	57,0	10,0	55,0	69,5	M16x1	15.512.50.25.Z/115	30614769
50	32,0	59,0	63,0	64,0	70,0	125,0	61,0	10,0	60,0	74,5	M16x1	15.512.50.32.Z/125	30614770

Dimensions in mm.

For accessories and spare parts see "Accessories and spare parts" section.
Additional dimensions and special designs available upon request.

Hydraulic compensation chuck

With axial tool length adjustment and radial alignment feature
Shank BT according to ISO 7388-2 Form JD (JIS B 6339)

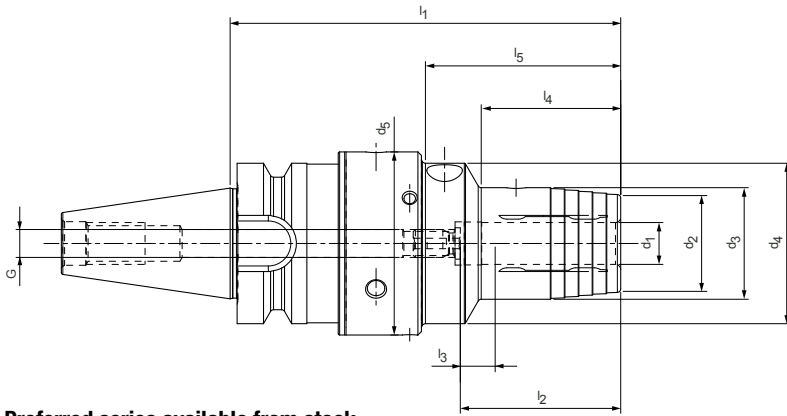

Preferred series available from stock

BT	Dimensions					G	Order designation	Order no.					
	d ₁	d ₂	d ₃	d ₄	d ₅								
30	12,0	28,0	32,0	46,0	52,5	112,0	46,0	10,0	40,0	56,0	M8x1	22.512.30.12.Z/112	30998006
30	20,0	38,0	42,0	46,0	52,5	122,0	51,0	10,0	50,0	66,0	M8x1	22.512.30.20.Z/122	30998036

Dimensions in mm.

For accessories and spare parts see "Accessories and spare parts" section.
Additional dimensions and special designs available upon request.

Hydraulic chuck

For tool sharpening and grinding machines, with axial tool length adjustment
Shank SK according to ISO 7388-1 Form AD

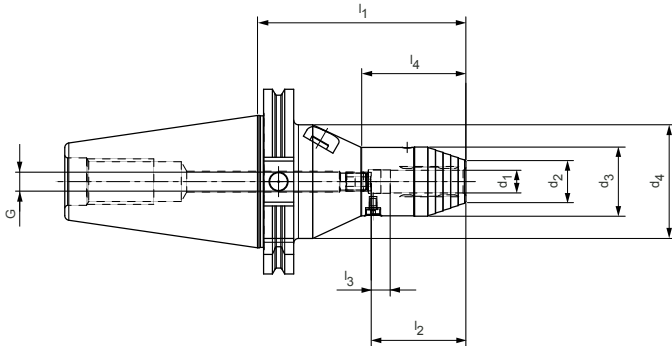

Available on request

SK/ISO	Dimensions								G	Order designation	Order no.
	d ₁	d ₂	d ₃	d ₄	l ₁	l ₂	l ₃	l ₄			
50	6,0	18,0	32,0	60,0	110,0	43,0	10,0	45,0	M5	15.509.50.06/110	30336773
50	8,0	19,5	33,5	60,0	110,0	43,0	10,0	50,0	M6	15.509.50.08/110	30336774
50	10,0	21,0	35,0	60,0	110,0	43,0	10,0	50,0	M8x1	15.509.50.10/110	30336775
50	12,0	22,5	36,5	60,0	110,0	50,0	10,0	55,0	M10x1	15.509.50.12/110	30336776
50	14,0	24,0	38,0	60,0	110,0	50,0	10,0	60,0	M10x1	15.509.50.14/110	30336777
50	16,0	25,5	39,5	60,0	110,0	53,0	10,0	60,0	M12x1	15.509.50.16/110	30336778
50	18,0	27,0	41,0	60,0	110,0	53,0	10,0	60,0	M12x1	15.509.50.18/110	30336779
50	20,0	28,0	42,0	70,0	110,0	95,0	10,0	41,0	M16x1	15.509.50.20/110	30336780
50	22,0	30,0	44,0	70,0	110,0	95,0	10,0	43,0	M16x1	15.509.50.22/110	30336781
50	25,0	33,0	47,0	70,0	110,0	95,0	10,0	40,0	M16x1	15.509.50.25/110	30336782
50	32,0	40,0	54,0	70,0	110,0	95,0	10,0	56,0	M16x1	15.509.50.32/110	30336783

Dimensions in mm.

For accessories and spare parts see "Accessories and spare parts" section.
Additional dimensions and special designs available upon request.

Hydraulic chuck

With axial tool length adjustment

Shank hollow shank taper E according to DIN 69893-5

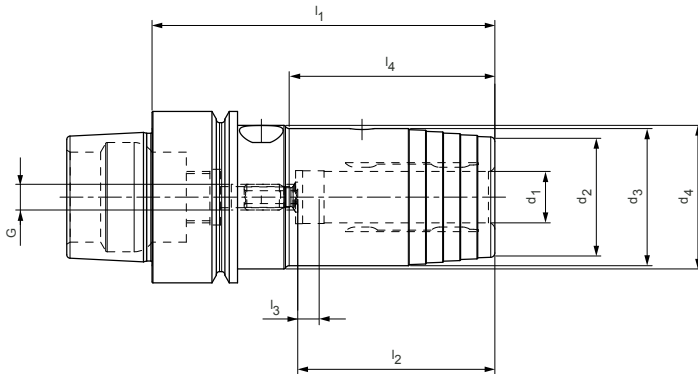

Preferred series available from stock

HSK-E	Dimensions								G	Order designation	Order no.
	d ₁	d ₂	d ₃	d ₄	l ₁	l ₂	l ₃	l ₄			
40	6,0	22,0	26,0	33,5	70,0	37,0	10,0	36,0	M5	18.507.40.06.Z/70	30336886
40	8,0	24,0	28,0	33,5	70,0	37,0	10,0	36,0	M6	18.507.40.08.Z/70	30336887
40	10,0	26,0	30,0	33,5	75,0	41,0	10,0	42,0	M6	18.507.40.10.Z/75	30336888
40	12,0	28,0	32,0	33,5	80,0	46,0	10,0	48,0	M6	18.507.40.12.Z/80	30336889
50	6,0	22,0	26,0	40,0	70,0	37,0	10,0	28,0	M5	18.507.50.06.Z/70	30336892
50	8,0	24,0	28,0	40,0	70,0	37,0	10,0	28,0	M6	18.507.50.08.Z/70	30336893
50	10,0	26,0	30,0	40,0	75,0	41,0	10,0	34,0	M8x1	18.507.50.10.Z/75	30336894
50	12,0	28,0	32,0	40,0	85,0	46,0	10,0	44,0	M10x1	18.507.50.12.Z/85	30336895
50	14,0	30,0	34,0	40,0	85,0	46,0	10,0	44,0	M10x1	18.507.50.14.Z/85	30336896
50	16,0	34,0	38,0	42,0	90,0	49,0	10,0	30,0	M12x1	18.507.50.16.Z/90	30336897
50	18,0	36,0	40,0	42,0	90,0	49,0	10,0	29,0	M12x1	18.507.50.18.Z/90	30336898
50	20,0	38,0	42,0	42,0	90,0	51,0	10,0	29,0	M16x1	18.507.50.20.Z/90	30336899

Dimensions in mm.

For accessories and spare parts see "Accessories and spare parts" section.

Additional dimensions and special designs available upon request.

Hydraulic chuck

With axial tool length adjustment
Shank HSK-F according to DIN 69893-6

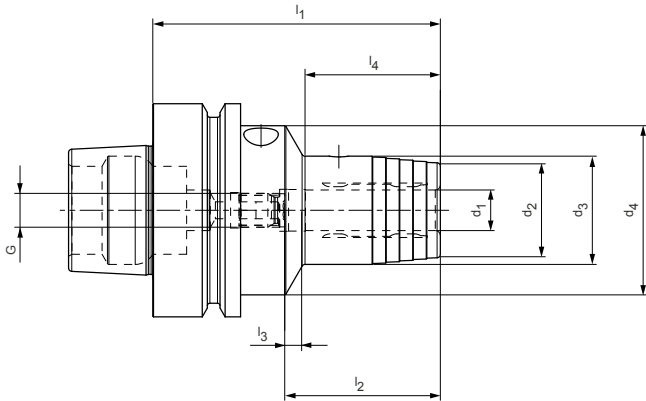

Available on request

HSK-F	Dimensions								G	Order designation	Order no.
	d ₁	d ₂	d ₃	d ₄	l ₁	l ₂	l ₃	l ₄			
63	6,0	22,0	26,0	50,0	70,0	37,0	10,0	24,0	M5	17.507.63.06/70	30336877
63	8,0	24,0	28,0	50,0	70,0	37,0	10,0	25,0	M6	17.507.63.08/70	30336878
63	10,0	26,0	30,0	50,0	75,0	41,0	10,0	35,0	M6	17.507.63.10/80	30336879
63	12,0	28,0	32,0	50,0	85,0	46,0	10,0	40,0	M6	17.507.63.12/85	30336880
63	14,0	30,0	34,0	50,0	85,0	46,0	10,0	40,0	M10x1	17.507.63.14/85	30336881
63	16,0	34,0	38,0	50,0	90,0	49,0	10,0	46,0	M12x1	17.507.63.16/90	30336882
63	18,0	36,0	40,0	50,0	90,0	49,0	10,0	47,0	M12x1	17.507.63.18/90	30336883
63	20,0	38,0	42,0	50,0	90,0	51,0	10,0	48,0	M16x1	17.507.63.20/90	30336884
63	25,0	53,0	57,0	53,0	120,0	57,0	10,0	63,0	M16x1	17.507.63.25/120	30336885

Dimensions in mm.

For accessories and spare parts see "Accessories and spare parts" section.
Additional dimensions and special designs available upon request.

Hydro-TurnChuck

Turning technology

1 Available as

- VDI 30/40
- Cylindrical shank 32/40

2 Clamping through hydraulic expansion bushing

3 Clamping screw

4 Fixing screw

5 Reducing bushing for flexible clamping diameters



WTE Hydro-TurnChuck

WTE is expanding its portfolio of clamping tools with a hydraulic chuck that makes the advantages of hydraulic expansion technology optimally usable on turning/milling centres.

The WTE Hydro-TurnChuck ensures high-precision clamping of the boring bar with shank tolerance h7 with an accuracy of repetition of 3 µm. A tool change takes place in a matter of seconds and can be carried out directly in the machine without peripheral devices.

The precise tension as well as the damping properties of the hydro expansion technology ensure that the surface roughness is reduced by up to 70 per cent compared to current solutions. The radially mounted adjusting screw is also responsible for this.

AT A GLANCE

- With length adjustment screw – can also be removed to allow the boring bar to be pushed through
- A screw to lock the boring bar in place
- Quick-change system
- Fine bore machining
- Flexible clamping of drilling and reaming tools



With length adjustment screw: For drilling and reaming work

Without length adjustment screw: For turning steels of different lengths

Hydro-TurnChuck

Hydraulic clamping insert for lathes with internal cooling

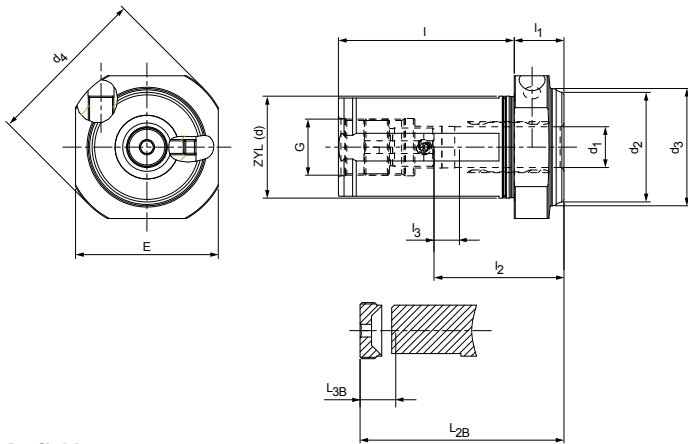

Available on request

ZYL (d)	Dimensions									G	L _{2B}	L _{3B}	Order designation	Order no.
	d ₁	d ₂	d ₃	d ₄	E	l	l ₁	l ₂	l ₃					
32	16,0	38,0	41,0	59,0	50,0	59,0	19,5	51,0	10,0	M22x1	70	14	41.560.32.16.Z/19,5	31183111
32	20,0	38,0	41,0	59,0	50,0	59,0	19,5	51,0	10,0	M22x1	70	14	41.560.32.20.Z/19,5	30782332
40	16,0	43,0	46,0	64,0	56,0	69,0	19,5	51,0	10,0	M22x1	80	14	41.560.40.16.Z/19,5	31183112
40	20,0	43,0	46,0	64,0	56,0	69,0	19,5	51,0	10,0	M22x1	80	14	41.560.40.20.Z/19,5	30898568
40	25,0	43,0	46,0	64,0	56,0	69,0	19,5	57,0	10,0	M27x1	80	14	41.560.40.25.Z/19,5	30337086

Hydro-hydraulic chuck VDI / DIN ISO 10889-1 for lathes with internal cooling

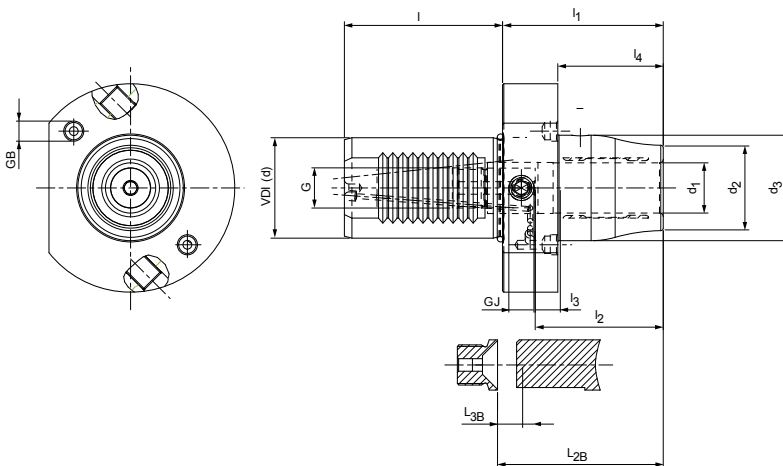

Available on request

VDI (d)	Dimensions									G	GJ	GB	L _{2B}	L _{3B}	Order designation	Order no.
	d ₁	d ₂	d ₃	l	l ₁	l ₂	l ₃	l ₄								
32	20,0	34,0	42,0	55,0	64,0	51,0	10,0	42,0		M16x1	M10	M8x1	66	10	49.560.30.20.Z/64	31152541
40	20,0	34,0	42,0	63,0	64,0	51,0	10,0	42,0		M16x1	M10	M8x1	66	10	49.560.40.20.Z/64	30337083

Dimensions in mm.

For accessories and spare parts see "Accessories and spare parts" section.
Additional dimensions and special designs available upon request.

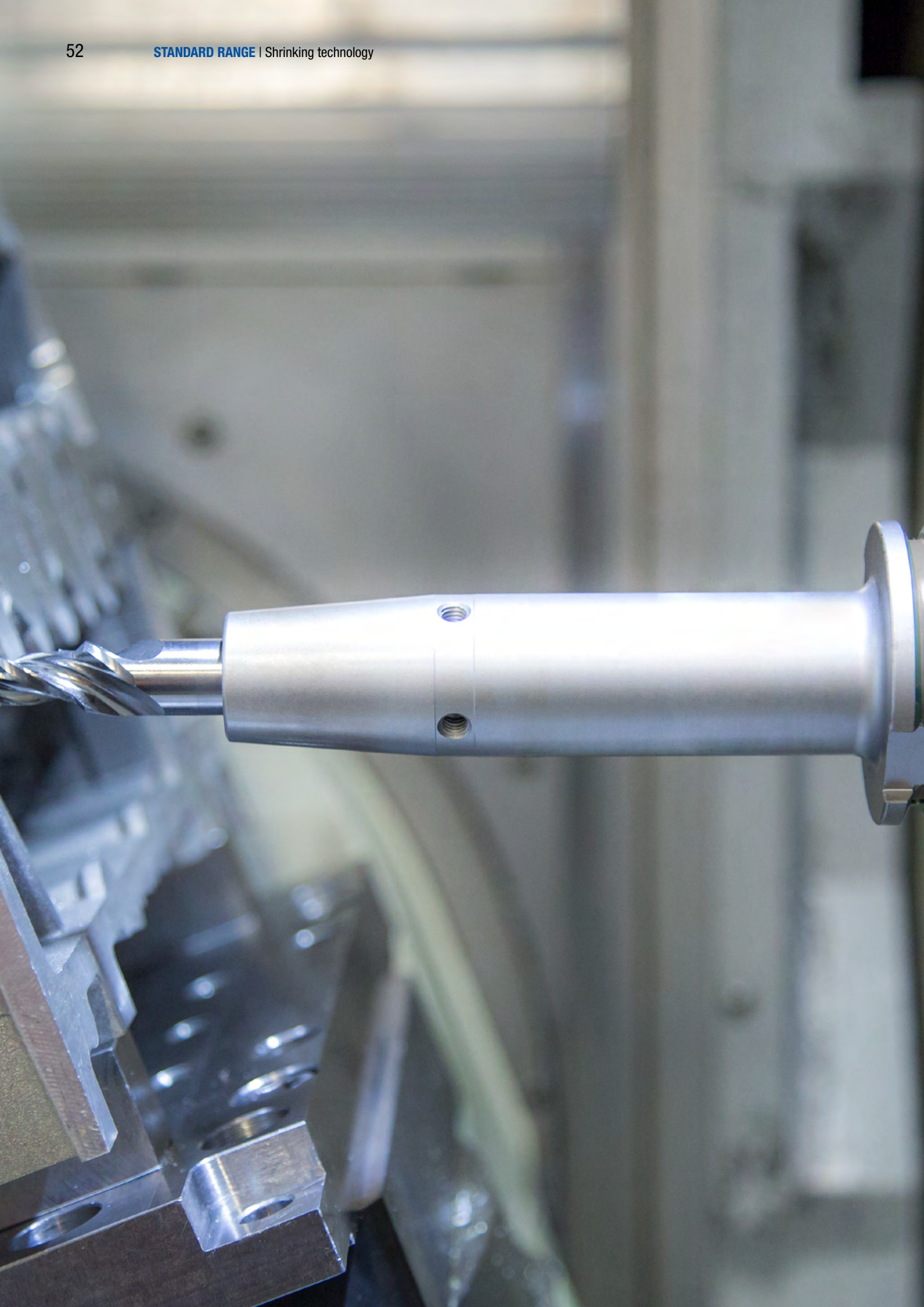

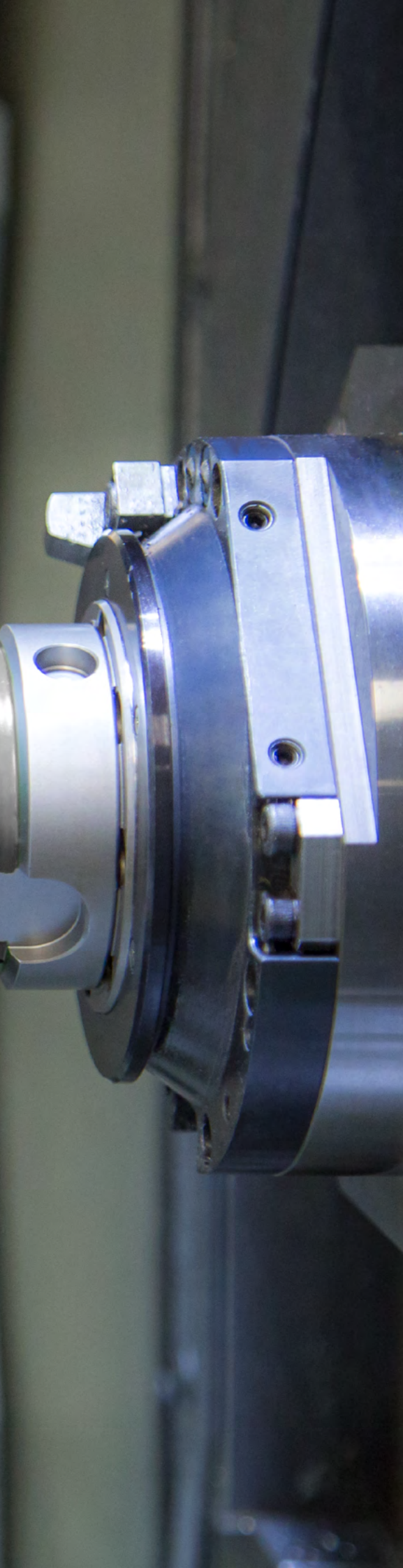

SHRINKING TECHNOLOGY

Shrink chuck

3° slim design with axial length adjustment	54
4.5° design with axial length adjustment	58
Design with coolant outlets and axial length adjustment	68

Shrink chuck

With axial tool length adjustment

HSK-A (hollow shank taper form A) shank according to DIN 69893-1

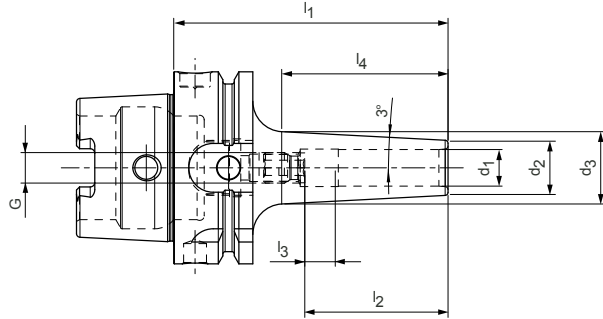

3° slim design | Preferred series available from stock

HSK-A	Dimensions							G	Order designation	Order no.
	d_1	d_2	d_3	l_1	l_2	l_3	l_4			
63	3,0	9,0	13,7	80,0	28,0	16,0	44,6	M6	16.304.63.03.Z/80	30385288
63*	3,0	9,0	16,0	120,0	12,0	-	66,7	-	16.304.63.03.Z/120	30385289
63	4,0	10,0	14,7	80,0	28,0	12,0	44,6	M6	16.304.63.04.Z/80	30385291
63*	4,0	10,0	17,0	120,0	16,0	-	66,7	-	16.304.63.04.Z/120	30385292
63	5,0	11,0	15,7	80,0	30,0	10,0	44,6	M6	16.304.63.05.Z/80	30385294
63*	5,0	11,0	18,0	120,0	20,0	-	66,7	-	16.304.63.05.Z/120	30385295
63	6,0	12,0	16,7	80,0	36,0	10,0	44,5	M5	16.304.63.06.Z/80	30385297
63	6,0	12,0	20,9	120,0	36,0	10,0	84,7	M5	16.304.63.06.Z/120	30385298
63	6,0	12,0	24,0	160,0	36,0	10,0	114,4	M5	16.304.63.06.Z/160	30385299
63	6,0	12,0	24,0	200,0	36,0	10,0	114,4	M5	16.304.63.06.Z/200	30596937
63	8,0	14,0	18,7	80,0	36,0	10,0	44,5	M6	16.304.63.08.Z/80	30385300
63	8,0	14,0	22,9	120,0	36,0	10,0	84,7	M6	16.304.63.08.Z/120	30385301
63	8,0	14,0	26,0	160,0	36,0	10,0	114,4	M6	16.304.63.08.Z/160	30385302
63	8,0	14,0	26,0	200,0	36,0	10,0	114,4	M6	16.304.63.08.Z/200	30596938
63	10,0	16,0	21,2	85,0	41,0	10,0	49,5	M8x1	16.304.63.10.Z/85	30385303
63	10,0	16,0	24,9	120,0	41,0	10,0	84,7	M8x1	16.304.63.10.Z/120	30385304
63	10,0	16,0	28,0	160,0	41,0	10,0	114,4	M8x1	16.304.63.10.Z/160	30385305
63	10,0	16,0	28,0	200,0	41,0	10,0	114,4	M8x1	16.304.63.10.Z/200	30596939
63	12,0	18,0	23,8	90,0	47,0	10,0	57,1	M10x1	16.304.63.12.Z/90	30385306
63	12,0	18,0	26,9	120,0	47,0	10,0	84,7	M10x1	16.304.63.12.Z/120	30385307
63	12,0	18,0	30,0	160,0	47,0	10,0	114,4	M10x1	16.304.63.12.Z/160	30385308
63	12,0	18,0	30,0	200,0	47,0	10,0	114,4	M10x1	16.304.63.12.Z/200	30596941
63	14,0	20,0	25,8	90,0	47,0	10,0	57,1	M10x1	16.304.63.14.Z/90	30385309
63	14,0	20,0	28,9	120,0	47,0	10,0	84,7	M10x1	16.304.63.14.Z/120	30385310
63	14,0	20,0	32,0	160,0	47,0	10,0	114,4	M10x1	16.304.63.14.Z/160	30385311
63	14,0	20,0	32,0	200,0	47,0	10,0	114,4	M10x1	16.304.63.14.Z/200	30596943
63	16,0	22,0	28,5	95,0	50,0	10,0	62,1	M12x1	16.304.63.16.Z/95	30385312
63	16,0	22,0	31,2	120,0	50,0	10,0	84,7	M12x1	16.304.63.16.Z/120	30385313
63	16,0	22,0	34,0	160,0	50,0	10,0	114,4	M12x1	16.304.63.16.Z/160	30385314
63	16,0	22,0	34,0	200,0	50,0	10,0	114,4	M12x1	16.304.63.16.Z/200	30596946
63	18,0	24,0	30,5	95,0	50,0	10,0	62,1	M12x1	16.304.63.18.Z/95	30385315
63	18,0	24,0	33,2	120,0	50,0	10,0	84,7	M12x1	16.304.63.18.Z/120	30385316
63	18,0	24,0	36,0	160,0	50,0	10,0	114,4	M12x1	16.304.63.18.Z/160	30385317
63	18,0	24,0	36,0	200,0	50,0	10,0	114,4	M12x1	16.304.63.18.Z/200	30596947
63	20,0	26,0	33,1	100,0	52,0	10,0	67,1	M16x1	16.304.63.20.Z/100	30385318
63	20,0	26,0	35,2	120,0	52,0	10,0	84,7	M16x1	16.304.63.20.Z/120	30385319
63	20,0	26,0	38,0	160,0	52,0	10,0	114,4	M16x1	16.304.63.20.Z/160	30385320
63	20,0	26,0	38,0	200,0	52,0	10,0	114,4	M16x1	16.304.63.20.Z/200	30596949

Slim design 3° | Available upon request

HSK-A	Dimensions							G	Order designation	Order no.
	d ₁	d ₂	d ₃	l ₁	l ₂	l ₃	l ₄			
100	6,0	12,0	17,0	85,0	36,0	10,0	41,8	M5	16.304.100.06.Z/85	30597883
100	6,0	12,0	20,0	120,0	36,0	10,0	76,8	M5	16.304.100.06.Z/120	30597904
100	6,0	12,0	23,0	160,0	36,0	10,0	104,9	M5	16.304.100.06.Z/160	30597918
100	6,0	12,0	27,0	200,0	36,0	10,0	143,1	M5	16.304.100.06.Z/200	30597934
100	8,0	14,0	19,0	85,0	36,0	10,0	41,8	M6	16.304.100.08.Z/85	30597886
100	8,0	14,0	22,0	120,0	36,0	10,0	76,8	M6	16.304.100.08.Z/120	30597906
100	8,0	14,0	25,0	160,0	36,0	10,0	104,9	M6	16.304.100.08.Z/160	30597921
100	8,0	14,0	27,0	200,0	36,0	10,0	124,0	M6	16.304.100.08.Z/200	30597935
100	10,0	16,0	21,0	90,0	41,0	10,0	46,8	M8x1	16.304.100.10.Z/90	30597889
100	10,0	16,0	24,0	120,0	41,0	10,0	76,8	M8x1	16.304.100.10.Z/120	30597909
100	10,0	16,0	27,0	160,0	41,0	10,0	104,9	M8x1	16.304.100.10.Z/160	30597923
100	10,0	16,0	31,0	200,0	41,0	10,0	143,1	M8x1	16.304.100.10.Z/200	30597937
100	12,0	18,0	24,0	95,0	47,0	10,0	51,8	M10x1	16.304.100.12.Z/95	30597890
100	12,0	18,0	26,0	120,0	47,0	10,0	76,8	M10x1	16.304.100.12.Z/120	30597911
100	12,0	18,0	29,0	160,0	47,0	10,0	104,9	M10x1	16.304.100.12.Z/160	30597924
100	12,0	18,0	32,0	200,0	47,0	10,0	133,5	M10x1	16.304.100.12.Z/200	30597939
100	14,0	20,0	26,0	95,0	47,0	10,0	51,8	M10x1	16.304.100.14.Z/95	30597891
100	14,0	20,0	28,0	120,0	47,0	10,0	76,8	M10x1	16.304.100.14.Z/120	30597912
100	14,0	20,0	30,0	160,0	47,0	10,0	95,4	M10x1	16.304.100.14.Z/160	30597926
100	14,0	20,0	34,0	200,0	47,0	10,0	133,5	M10x1	16.304.100.14.Z/200	30597941
100	16,0	22,0	28,0	100,0	50,0	10,0	56,8	M12x1	16.304.100.16.Z/100	30597892
100	16,0	22,0	30,0	120,0	50,0	10,0	76,8	M12x1	16.304.100.16.Z/120	30597913
100	16,0	22,0	32,0	160,0	50,0	10,0	95,4	M12x1	16.304.100.16.Z/160	30597927
100	16,0	22,0	34,0	200,0	50,0	10,0	114,4	M12x1	16.304.100.16.Z/200	30597943
100	18,0	24,0	30,0	100,0	50,0	10,0	56,8	M12x1	16.304.100.18.Z/100	30597894
100	18,0	24,0	32,0	120,0	50,0	10,0	76,8	M12x1	16.304.100.18.Z/120	30597915
100	18,0	24,0	36,0	160,0	50,0	10,0	114,4	M12x1	16.304.100.18.Z/160	30597929
100	18,0	24,0	40,0	200,0	50,0	10,0	152,6	M12x1	16.304.100.18.Z/200	30597944
100	20,0	27,0	34,0	105,0	52,0	10,0	61,8	M16x1	16.304.100.20.Z/105	30597896
100	20,0	27,0	35,0	120,0	52,0	10,0	76,8	M16x1	16.304.100.20.Z/120	30597917
100	20,0	27,0	42,0	160,0	52,0	10,0	104,9	M16x1	16.304.100.20.Z/160	30597931
100	20,0	27,0	42,0	200,0	52,0	10,0	146,1	M16x1	16.304.100.20.Z/200	30597945

* Without axial tool length adjustment

Dimensions in mm.

For accessories and spare parts see "Accessories and spare parts" section.

Additional dimensions and special designs available upon request.

Shrink chuck

With axial tool length adjustment

SK shank according to ISO 7388-1 Form AD/AF

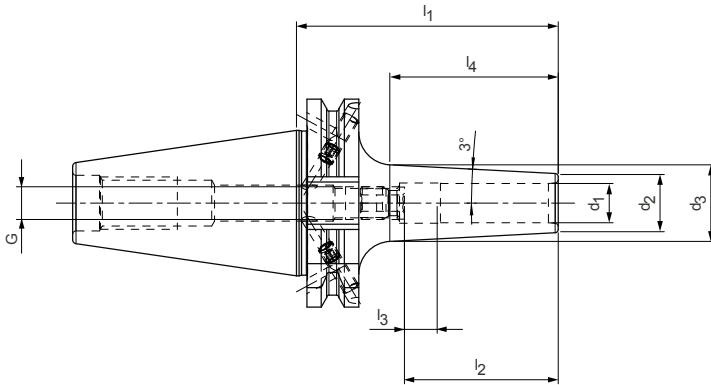

3° slim design | Preferred series available from stock

Steep taper	Dimensions							G	Order designation	Order no.
	d_1	d_2	d_3	l_1	l_2	l_3	l_4			
40	3,0	9,0	14,4	80,0	28,0	16,0	51,5	M6	15.304.40.03.Z/80	30385321
40*	3,0	9,0	16,0	120,0	12,0	-	66,7	-	15.304.40.03.Z/120	30385322
40	4,0	10,0	15,4	80,0	28,0	12,0	51,5	M6	15.304.40.04.Z/80	30385324
40*	4,0	10,0	17,0	120,0	16,0	-	66,7	-	15.304.40.04.Z/120	30385325
40	5,0	11,0	16,4	80,0	30,0	10,0	51,5	M6	15.304.40.05.Z/80	30385327
40*	5,0	11,0	18,0	120,0	20,0	-	66,7	-	15.304.40.05.Z/120	30385328
40	6,0	12,0	17,4	80,0	36,0	10,0	51,5	M5	15.304.40.06.Z/80	30385330
40	6,0	12,0	21,6	120,0	36,0	10,0	91,5	M5	15.304.40.06.Z/120	30385331
40	6,0	12,0	24,0	160,0	36,0	10,0	114,4	M5	15.304.40.06.Z/160	30385332
40	6,0	12,0	24,0	200,0	36,0	10,0	114,4	M5	15.304.40.06.Z/200	30596519
40	8,0	14,0	19,4	80,0	36,0	10,0	51,5	M6	15.304.40.08.Z/80	30385333
40	8,0	14,0	23,6	120,0	36,0	10,0	91,2	M6	15.304.40.08.Z/120	30385334
40	8,0	14,0	26,0	160,0	36,0	10,0	114,4	M6	15.304.40.08.Z/160	30385335
40	8,0	14,0	26,0	200,0	36,0	10,0	114,4	M6	15.304.40.08.Z/200	30596520
40	10,0	16,0	21,4	80,0	41,0	10,0	51,5	M8x1	15.304.40.10.Z/80	30385336
40	10,0	16,0	25,6	120,0	41,0	10,0	91,2	M8x1	15.304.40.10.Z/120	30385337
40	10,0	16,0	28,0	160,0	41,0	10,0	114,4	M8x1	15.304.40.10.Z/160	30385338
40	10,0	16,0	28,0	200,0	41,0	10,0	114,4	M8x1	15.304.40.10.Z/200	30596521
40	12,0	18,0	23,4	80,0	47,0	10,0	51,5	M10x1	15.304.40.12.Z/80	30385339
40	12,0	18,0	27,9	120,0	47,0	10,0	94,1	M10x1	15.304.40.12.Z/120	30385340
40	12,0	18,0	30,0	160,0	47,0	10,0	114,4	M10x1	15.304.40.12.Z/160	30385341
40	12,0	18,0	30,0	200,0	47,0	10,0	114,4	M10x1	15.304.40.12.Z/200	30596522
40	14,0	20,0	25,7	80,0	47,0	10,0	53,9	M10x1	15.304.40.14.Z/80	30385342
40	14,0	20,0	30,1	120,0	47,0	10,0	96,4	M10x1	15.304.40.14.Z/120	30385343
40	14,0	20,0	32,0	160,0	47,0	10,0	114,4	M10x1	15.304.40.14.Z/160	30385344
40	14,0	20,0	32,0	200,0	47,0	10,0	114,4	M10x1	15.304.40.14.Z/200	30596523
40	16,0	22,0	27,7	80,0	50,0	10,0	53,9	M12x1	15.304.40.16.Z/80	30385345
40	16,0	22,0	32,1	120,0	50,0	10,0	96,4	M12x1	15.304.40.16.Z/120	30385346
40	16,0	22,0	34,0	160,0	50,0	10,0	114,4	M12x1	15.304.40.16.Z/160	30385347
40	16,0	22,0	34,0	200,0	50,0	10,0	114,4	M12x1	15.304.40.16.Z/200	30596525
40	18,0	24,0	29,7	80,0	50,0	10,0	53,9	M12x1	15.304.40.18.Z/80	30385348
40	18,0	24,0	34,4	120,0	50,0	10,0	98,6	M12x1	15.304.40.18.Z/120	30385349
40	18,0	24,0	36,0	160,0	50,0	10,0	114,4	M12x1	15.304.40.18.Z/160	30385350
40	18,0	24,0	36,0	200,0	50,0	10,0	56,4	M12x1	15.304.40.18.Z/200	30596526
40	20,0	26,0	31,9	80,0	52,0	10,0	98,6	M16x1	15.304.40.20.Z/80	30385351
40	20,0	26,0	36,4	120,0	52,0	10,0	114,4	M16x1	15.304.40.20.Z/120	30385352
40	20,0	26,0	38,0	160,0	52,0	10,0	114,4	M16x1	15.304.40.20.Z/160	30385353
40	20,0	26,0	38,0	200,0	52,0	10,0	114,4	M16x1	15.304.40.20.Z/200	30596528

Dimensions in mm.

For accessories and spare parts see "Accessories and spare parts" section.

Additional dimensions and special designs available upon request.

* Without axial tool length adjustment

Shrink chuck

With axial tool length adjustment

Shank BT according to ISO 7388-2 Form JD/JF (JIS B 6339)

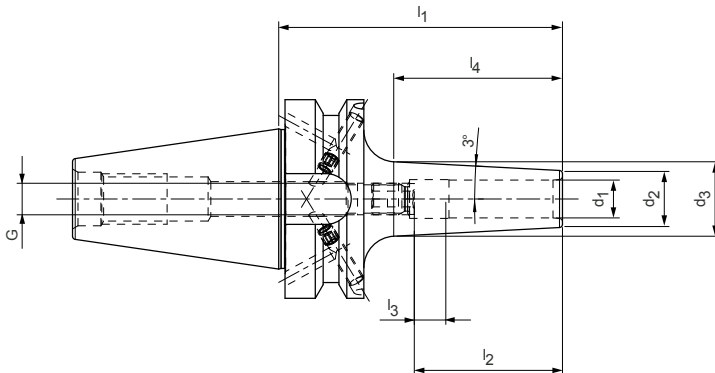

3° slim design | Preferred series available from stock

BT	Dimensions							G	Order designation	Order no.
	d_1	d_2	d_3	l_1	l_2	l_3	l_4			
40	3,0	9,0	14,7	90,0	28,0	16,0	53,5	M6	22.304.40.03.Z/90	30385354
40*	3,0	9,0	16,0	120,0	12,0	-	66,7	-	22.304.40.03.Z/120	30385355
40	4,0	10,0	15,7	90,0	28,0	12,0	53,5	M6	22.304.40.04.Z/90	30385357
40*	4,0	10,0	17,0	120,0	16,0	-	66,7	-	22.304.40.04.Z/120	30385358
40	5,0	11,0	16,7	90,0	30,0	10,0	53,5	M6	22.304.40.05.Z/90	30385360
40*	5,0	11,0	18,0	120,0	20,0	-	66,7	-	22.304.40.05.Z/120	30385361
40	6,0	12,0	17,7	90,0	36,0	10,0	53,5	M5	22.304.40.06.Z/90	30385363
40	6,0	12,0	20,8	120,0	36,0	10,0	83,5	M5	22.304.40.06.Z/120	30385364
40	6,0	12,0	24,0	160,0	36,0	10,0	114,4	M5	22.304.40.06.Z/160	30385365
40	6,0	12,0	24,0	200,0	36,0	10,0	114,4	M5	22.304.40.06.Z/200	30597096
40	8,0	14,0	19,7	90,0	36,0	10,0	53,5	M6	22.304.40.08.Z/90	30385366
40	8,0	14,0	22,8	120,0	36,0	10,0	83,5	M6	22.304.40.08.Z/120	30385367
40	8,0	14,0	26,0	160,0	36,0	10,0	114,4	M6	22.304.40.08.Z/160	30385368
40	8,0	14,0	26,0	200,0	36,0	10,0	114,4	M6	22.304.40.08.Z/200	30597098
40	10,0	16,0	21,7	90,0	41,0	10,0	53,5	M8x1	22.304.40.10.Z/90	30385369
40	10,0	16,0	24,8	120,0	41,0	10,0	83,5	M8x1	22.304.40.10.Z/120	30385370
40	10,0	16,0	28,0	160,0	41,0	10,0	114,4	M8x1	22.304.40.10.Z/160	30385371
40	10,0	16,0	28,0	200,0	41,0	10,0	114,4	M8x1	22.304.40.10.Z/200	30597099
40	12,0	18,0	23,7	90,0	47,0	10,0	53,5	M10x1	22.304.40.12.Z/90	30385372
40	12,0	18,0	27,0	120,0	47,0	10,0	83,5	M10x1	22.304.40.12.Z/120	30385373
40	12,0	18,0	30,0	160,0	47,0	10,0	114,4	M10x1	22.304.40.12.Z/160	30385374
40	12,0	18,0	30,0	200,0	47,0	10,0	114,4	M10x1	22.304.40.12.Z/200	30597100
40	14,0	20,0	25,9	90,0	47,0	10,0	55,8	M10x1	22.304.40.14.Z/90	30385375
40	14,0	20,0	29,3	120,0	47,0	10,0	88,2	M10x1	22.304.40.14.Z/120	30385376
40	14,0	20,0	32,0	160,0	47,0	10,0	114,4	M10x1	22.304.40.14.Z/160	30385377
40	14,0	20,0	32,0	200,0	47,0	10,0	114,4	M10x1	22.304.40.14.Z/200	30597101
40	16,0	22,0	27,9	90,0	50,0	10,0	55,8	M12x1	22.304.40.16.Z/90	30385378
40	16,0	22,0	31,3	120,0	50,0	10,0	88,2	M12x1	22.304.40.16.Z/120	30385379
40	16,0	22,0	34,0	160,0	50,0	10,0	114,4	M12x1	22.304.40.16.Z/160	30385380
40	16,0	22,0	34,0	200,0	50,0	10,0	114,4	M12x1	22.304.40.16.Z/200	30597102
40	18,0	24,0	29,9	90,0	50,0	10,0	55,8	M12x1	22.304.40.18.Z/90	30385381
40	18,0	24,0	33,5	120,0	50,0	10,0	90,6	M12x1	22.304.40.18.Z/120	30385382
40	18,0	24,0	36,0	160,0	50,0	10,0	114,4	M12x1	22.304.40.18.Z/160	30385383
40	18,0	24,0	36,0	200,0	50,0	10,0	114,4	M12x1	22.304.40.18.Z/200	30597104
40	20,0	26,0	32,2	90,0	52,0	10,0	58,2	M16x1	22.304.40.20.Z/90	30385384
40	20,0	26,0	35,5	120,0	52,0	10,0	90,6	M16x1	22.304.40.20.Z/120	30385385
40	20,0	26,0	38,0	160,0	52,0	10,0	114,4	M16x1	22.304.40.20.Z/160	30385386
40	20,0	26,0	38,0	200,0	52,0	10,0	114,4	M16x1	22.304.40.20.Z/200	30597107

Dimensions in mm.

For accessories and spare parts see "Accessories and spare parts" section.

Additional dimensions and special designs available upon request.

* Without axial tool length adjustment

Shrink chuck

With axial tool length adjustment

HSK-A (hollow shank taper form A) shank according to DIN 69893-1

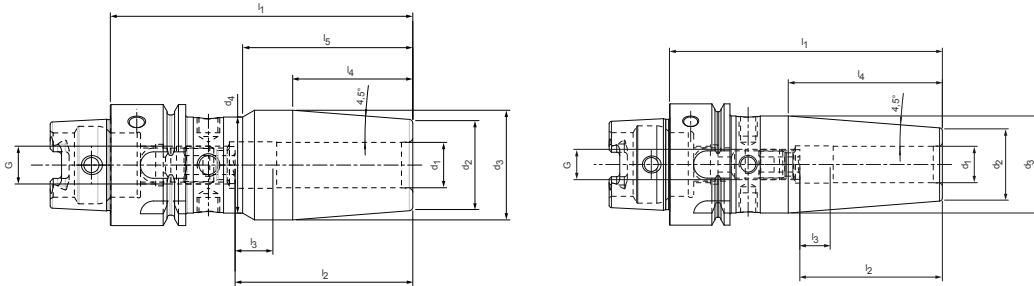

Preferred series available from stock

HSK-A	Dimensions									G	Order designation	Order no.
	d ₁	d ₂	d ₃	d ₄	l ₁	l ₂	l ₃	l ₄	l ₅			
32	3,0	10,0	15,0	-	60,0	28,0	16,0	31,7	-	M5	16.306.32.03.Z/60	30337360
32	4,0	10,0	15,0	-	60,0	28,0	12,0	31,7	-	M5	16.306.32.04.Z/60	30337361
32	5,0	10,0	15,0	-	60,0	30,0	10,0	31,7	-	M6	16.306.32.05.Z/60	30337362
32	6,0	21,0	25,0	-	70,0	36,0	10,0	25,4	-	M5	16.306.32.06.Z/70	30337363
32	8,0	21,0	25,0	-	70,0	36,0	10,0	25,4	-	M6	16.306.32.08.Z/70	30337364
32	10,0	24,0	29,0	25,4	75,0	41,0	10,0	37	40	M8x1	16.306.32.10.Z/75	30337365
32	12,0	24,0	29,0	25,4	80,0	47,0	10,0	42	45	M10x1	16.306.32.12.Z/80	30337366
40	3,0	10,0	15,0	-	60,0	28,0	16,0	31,7	-	M6	16.306.40.03.Z/60	30337367
40	4,0	10,0	15,0	-	60,0	28,0	12,0	31,7	-	M6	16.306.40.04.Z/60	30337370
40	5,0	10,0	15,0	-	60,0	30,0	10,0	31,7	-	M6	16.306.40.05.Z/60	30337373
40	6,0	21,0	27,0	-	80,0	36,0	10,0	38,1	-	M5	16.306.40.06.Z/80	30337376
40	8,0	21,0	27,0	-	80,0	36,0	10,0	38,1	-	M6	16.306.40.08.Z/80	30337379
40	10,0	24,0	32,0	-	80,0	41,0	10,0	50,2	-	M8x1	16.306.40.10.Z/80	30337382
40	12,0	24,0	32,0	-	90,0	47,0	10,0	51	-	M10x1	16.306.40.12.Z/90	30337385
40	14,0	27,0	33,5	-	90,0	47,0	10,0	41,3	-	M10x1	16.306.40.14.Z/90	30337388
40	16,0	27,0	33,5	-	90,0	50,0	10,0	41,3	-	M12x1	16.306.40.16.Z/90	30337391
50	3,0	10,0	15,0	-	80,0	28,0	16,0	31,7	-	M6	16.306.50.03.Z/80	30337394
50	4,0	15,0	22,0	-	80,0	28,0	12,0	44,4	-	M6	16.306.50.04.Z/80	30337397
50	5,0	15,0	22,0	-	80,0	30,0	10,0	44,4	-	M6	16.306.50.05.Z/80	30337400
50	6,0	21,0	27,0	-	80,0	36,0	10,0	38,1	-	M5	16.306.50.06.Z/80	30337403
50	8,0	21,0	27,0	-	80,0	36,0	10,0	38,1	-	M6	16.306.50.08.Z/80	30337407
50	10,0	24,0	32,0	-	85,0	41,0	10,0	49	-	M8x1	16.306.50.10.Z/85	30337410
50	12,0	24,0	32,0	-	90,0	47,0	10,0	50,8	-	M10x1	16.306.50.12.Z/90	30337413
50	14,0	27,0	34,0	-	90,0	47,0	10,0	44,4	-	M10x1	16.306.50.14.Z/90	30337416
50	16,0	27,0	34,0	-	95,0	50,0	10,0	44,4	-	M12x1	16.306.50.16.Z/95	30337419
50	18,0	33,0	41,5	-	95,0	50,0	10,0	54	-	M12x1	16.306.50.18.Z/95	30337422
50	20,0	33,0	41,5	-	100,0	52,0	10,0	54	-	M16x1	16.306.50.20.Z/100	30337425
63	3,0	10,0	15,0	-	80,0	28,0	16,0	31,7	-	M6	16.306.63.03.Z/80	30337115
63*	3,0	10,0	20,0	-	120,0	12,0	-	63,5	-	-	16.306.63.03.Z/120	30337428
63	4,0	15,0	22,0	-	80,0	28,0	12,0	44,4	-	M6	16.306.63.04.Z/80	30337116
63*	4,0	15,0	22,0	-	120,0	16,0	-	44,4	-	-	16.306.63.04.Z/120	30337430
63	5,0	15,0	22,0	-	80,0	30,0	10,0	44,4	-	M6	16.306.63.05.Z/80	30337117
63*	5,0	15,0	22,0	-	120,0	20,0	-	44,4	-	-	16.306.63.05.Z/120	30337432
63	6,0	21,0	27,0	-	80,0	36,0	10,0	44,4	-	M5	16.306.63.06.Z/80	30337118
63	6,0	21,0	27,0	-	120,0	36,0	10,0	84	-	M5	16.306.63.06.Z/120	30337434
63	6,0	21,0	27,0	-	160,0	36,0	10,0	38,1	-	M5	16.306.63.06.Z/160	30337435
63	6,0	21,0	27,0	-	200,0	36,0	10,0	38,1	-	M5	16.306.63.06.Z/200	30526480
63	8,0	21,0	27,0	-	80,0	36,0	10,0	44,4	-	M6	16.306.63.08.Z/80	30337120
63	8,0	21,0	27,0	-	120,0	36,0	10,0	38,1	-	M6	16.306.63.08.Z/120	30337436

Shrink chuck DIN 69893-1 | Preferred series available from stock

HSK-A	Dimensions									G	Order designation	Order no.
	d ₁	d ₂	d ₃	d ₄	l ₁	l ₂	l ₃	l ₄	l ₅			
63	8,0	21,0	27,0	-	160,0	36,0	10,0	38,1	-	M6	16.306.63.08.Z/160	30337437
63	8,0	21,0	27,0	-	200,0	36,0	10,0	38,1	-	M6	16.306.63.08.Z/200	30337438
63	10,0	24,0	32,0	-	85,0	41,0	10,0	49,4	-	M8x1	16.306.63.10.Z/85	30337122
63	10,0	24,0	32,0	-	120,0	41,0	10,0	50,8	-	M8x1	16.306.63.10.Z/120	30337439
63	10,0	24,0	32,0	-	160,0	41,0	10,0	50,8	-	M8x1	16.306.63.10.Z/160	30337440
63	10,0	24,0	32,0	-	200,0	41,0	10,0	50,8	-	M8x1	16.306.63.10.Z/200	30419210
63	12,0	24,0	32,0	-	90,0	47,0	10,0	50,8	-	M10x1	16.306.63.12.Z/90	30337124
63	12,0	24,0	32,0	-	120,0	47,0	10,0	50,8	-	M10x1	16.306.63.12.Z/120	30337441
63	12,0	24,0	32,0	-	160,0	47,0	10,0	50,8	-	M10x1	16.306.63.12.Z/160	30337442
63	12,0	24,0	32,0	-	200,0	47,0	10,0	50,8	-	M10x1	16.306.63.12.Z/200	30425006
63	14,0	27,0	34,0	-	90,0	47,0	10,0	44,4	-	M10x1	16.306.63.14.Z/90	30337126
63	14,0	27,0	34,0	-	120,0	47,0	10,0	44,4	-	M10x1	16.306.63.14.Z/120	30337443
63	14,0	27,0	34,0	-	160,0	47,0	10,0	44,4	-	M10x1	16.306.63.14.Z/160	30337444
63	14,0	27,0	34,0	-	200,0	47,0	10,0	44,4	-	M10x1	16.306.63.14.Z/200	30526482
63	16,0	27,0	34,0	-	95,0	50,0	10,0	44,4	-	M12x1	16.306.63.16.Z/95	30337128
63	16,0	27,0	34,0	-	120,0	50,0	10,0	44,4	-	M12x1	16.306.63.16.Z/120	30337445
63	16,0	27,0	34,0	-	160,0	50,0	10,0	44,4	-	M12x1	16.306.63.16.Z/160	30337446
63	16,0	27,0	34,0	-	200,0	50,0	10,0	44,4	-	M12x1	16.306.63.16.Z/200	30526485
63	18,0	33,0	42,0	-	95,0	50,0	10,0	57,1	-	M12x1	16.306.63.18.Z/95	30337129
63	18,0	33,0	42,0	-	120,0	50,0	10,0	57,1	-	M12x1	16.306.63.18.Z/120	30337447
63	18,0	33,0	42,0	-	160,0	50,0	10,0	57,1	-	M12x1	16.306.63.18.Z/160	30337448
63	18,0	33,0	42,0	-	200,0	50,0	10,0	57,1	-	M12x1	16.306.63.18.Z/200	30526487
63	20,0	33,0	42,0	-	100,0	52,0	10,0	57,1	-	M16x1	16.306.63.20.Z/100	30337130
63	20,0	33,0	42,0	-	120,0	52,0	10,0	57,1	-	M16x1	16.306.63.20.Z/120	30337449
63	20,0	33,0	42,0	-	160,0	52,0	10,0	57,1	-	M16x1	16.306.63.20.Z/160	30337450
63	20,0	33,0	42,0	-	200,0	52,0	10,0	57,1	-	M16x1	16.306.63.20.Z/200	30526488
63	25,0	44,0	52,5	-	115,0	58,0	10,0	54	-	M16x1	16.306.63.25.Z/115	30337131
63	25,0	44,0	52,5	-	120,0	58,0	10,0	54	-	M16x1	16.306.63.25.Z/120	30337451
63	25,0	44,0	52,5	-	160,0	58,0	10,0	54	-	M16x1	16.306.63.25.Z/160	30337452
63	25,0	44,0	52,5	-	200,0	58,0	10,0	54	-	M16x1	16.306.63.25.Z/200	30526489
63	32,0	44,0	52,5	-	120,0	62,0	10,0	54	-	M16x1	16.306.63.32.Z/120	30337132
63	32,0	44,0	52,5	-	160,0	62,0	10,0	54	-	M16x1	16.306.63.32.Z/160	30337453
63	32,0	44,0	52,5	-	200,0	62,0	10,0	54	-	M16x1	16.306.63.32.Z/200	30526491
80	6,0	21,0	27,0	-	85,0	36,0	10,0	38,1	-	M5	16.306.80.06.Z/85	30337454
80	8,0	21,0	27,0	-	85,0	36,0	10,0	38,1	-	M6	16.306.80.08.Z/85	30337457
80	10,0	24,0	32,0	-	90,0	41,0	10,0	53,3	-	M8x1	16.306.80.10.Z/90	30337460
80	12,0	24,0	32,0	-	95,0	47,0	10,0	50,8	-	M10x1	16.306.80.12.Z/95	30337463
80	14,0	27,0	34,0	-	95,0	47,0	10,0	44,4	-	M10x1	16.306.80.14.Z/95	30337466
80	16,0	27,0	34,0	-	100,0	50,0	10,0	44,4	-	M12x1	16.306.80.16.Z/100	30337469
80	18,0	33,0	42,0	-	100,0	50,0	10,0	56,4	-	M12x1	16.306.80.18.Z/100	30337472
80	20,0	33,0	42,0	-	105,0	52,0	10,0	57,1	-	M16x1	16.306.80.20.Z/105	30337475
80	25,0	44,0	53,0	-	115,0	58,0	10,0	57,1	-	M16x1	16.306.80.25.Z/115	30337478
80	32,0	44,0	53,0	-	120,0	62,0	10,0	57,1	-	M16x1	16.306.80.32.Z/120	30337481
100	6,0	21,0	27,0	-	85,0	36,0	10,0	38,1	-	M5	16.306.100.06.Z.85	30337331
100	6,0	21,0	27,0	-	120,0	36,0	10,0	38,1	-	M5	16.306.100.06.Z/120	30337332
100	6,0	21,0	27,0	-	160,0	36,0	10,0	38,1	-	M5	16.306.100.06.Z/160	30337333
100	6,0	21,0	27,0	-	200,0	36,0	10,0	38,1	-	M5	16.306.100.06.Z/200	30530904
100	8,0	21,0	27,0	-	85,0	36,0	10,0	38,1	-	M6	16.306.100.08.Z/85	30337334
100	8,0	21,0	27,0	-	120,0	36,0	10,0	38,1	-	M6	16.306.100.08.Z/120	30337335
100	8,0	21,0	27,0	-	160,0	36,0	10,0	38,1	-	M6	16.306.100.08.Z/160	30337336
100	8,0	21,0	27,0	-	200,0	36,0	10,0	38,1	-	M6	16.306.100.08.Z/200	30530906
100	10,0	24,0	32,0	-	90,0	41,0	10,0	53,8	-	M8x1	16.306.100.10.Z/90	30337337
100	10,0	24,0	32,0	-	120,0	41,0	10,0	50,8	-	M8x1	16.306.100.10.Z/120	30337338
100	10,0	24,0	32,0	-	160,0	41,0	10,0	50,8	-	M8x1	16.306.100.10.Z/160	30337339
100	10,0	24,0	32,0	-	200,0	41,0	10,0	50,8	-	M8x1	16.306.100.10.Z/200	30408832
100	12,0	24,0	32,0	-	95,0	47,0	10,0	50,8	-	M10x1	16.306.100.12.Z/95	30337340
100	12,0	24,0	32,0	-	120,0	47,0	10,0	50,8	-	M10x1	16.306.100.12.Z/120	30337341

Continued on next page.

Shrink chuck DIN 69893-1 | Preferred series available from stock

HSK-A	Dimensions									G	Order designation	Order no.
	d ₁	d ₂	d ₃	d ₄	l ₁	l ₂	l ₃	l ₄	l ₅			
100	12,0	24,0	32,0	-	160,0	47,0	10,0	50,8	-	M10x1	16.306.100.12.Z/160	30337342
100	12,0	24,0	32,0	-	200,0	47,0	10,0	50,8	-	M10x1	16.306.100.12.Z/200	30530907
100	14,0	27,0	34,0	-	95,0	47,0	10,0	44,7	-	M10x1	16.306.100.14.Z/95	30337343
100	14,0	27,0	34,0	-	120,0	47,0	10,0	44,7	-	M10x1	16.306.100.14.Z/120	30337344
100	14,0	27,0	34,0	-	160,0	47,0	10,0	44,7	-	M10x1	16.306.100.14.Z/160	30337345
100	14,0	27,0	34,0	-	200,0	47,0	10,0	44,7	-	M10x1	16.306.100.14.Z/200	30530909
100	16,0	27,0	34,0	-	100,0	50,0	10,0	44,7	-	M12x1	16.306.100.16.Z/100	30337346
100	16,0	27,0	34,0	-	120,0	50,0	10,0	44,7	-	M12x1	16.306.100.16.Z/120	30337347
100	16,0	27,0	34,0	-	160,0	50,0	10,0	44,7	-	M12x1	16.306.100.16.Z/160	30337348
100	16,0	27,0	34,0	-	200,0	50,0	10,0	44,7	-	M12x1	16.306.100.16.Z/200	30530910
100	18,0	33,0	42,0	-	100,0	50,0	10,0	61,2	-	M12x1	16.306.100.18.Z/100	30337349
100	18,0	33,0	42,0	-	120,0	50,0	10,0	57,1	-	M12x1	16.306.100.18.Z/120	30337350
100	18,0	33,0	42,0	-	160,0	50,0	10,0	57,1	-	M12x1	16.306.100.18.Z/160	30337351
100	18,0	33,0	42,0	-	200,0	50,0	10,0	57,1	-	M12x1	16.306.100.18.Z/200	30530911
100	20,0	33,0	42,0	-	105,0	52,0	10,0	57,1	-	M16x1	16.306.100.20.Z/105	30337352
100	20,0	33,0	42,0	-	120,0	52,0	10,0	57,1	-	M16x1	16.306.100.20.Z/120	30337353
100	20,0	33,0	42,0	-	160,0	52,0	10,0	57,1	-	M16x1	16.306.100.20.Z/160	30337354
100	20,0	33,0	42,0	-	200,0	52,0	10,0	57,1	-	M16x1	16.306.100.20.Z/200	30530912
100	25,0	44,0	53,0	-	115,0	58,0	10,0	57,1	-	M16x1	16.306.100.25.Z/115	30337355
100	25,0	44,0	53,0	-	120,0	58,0	10,0	57,1	-	M16x1	16.306.100.25.Z/120	30337356
100	25,0	44,0	53,0	-	160,0	58,0	10,0	57,1	-	M16x1	16.306.100.25.Z/160	30337357
100	25,0	44,0	53,0	-	200,0	58,0	10,0	57,1	-	M16x1	16.306.100.25.Z/200	30530913
100	32,0	44,0	53,0	-	120,0	62,0	10,0	57,1	-	M16x1	16.306.100.32.Z/120	30337358
100	32,0	44,0	53,0	-	160,0	62,0	10,0	57,1	-	M16x1	16.306.100.32.Z/160	30337359
100	32,0	44,0	53,0	-	200,0	62,0	10,0	57,1	-	M16x1	16.306.100.32.Z/200	30530916

* Without axial tool length adjustment

Dimensions in mm.

For accessories and spare parts see "Accessories and spare parts" section.
Additional dimensions and special designs available upon request.

Shrink chuck

With axial tool length adjustment

SK shank according to ISO 7388-1 Form AD/AF

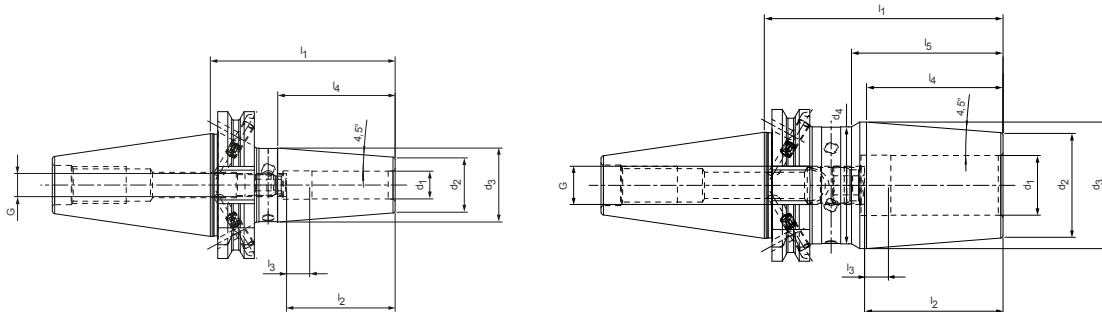

Preferred series available from stock

Steep taper	Dimensions									G	Order designation	Order no.
	d ₁	d ₂	d ₃	d ₄	l ₁	l ₂	l ₃	l ₄	l ₅			
30*	3,0	10,0	17,0	-	80,0	28,0	16,0	44,5	-	M6	15.306.30.03.Z/80	30337201
30*	4,0	15,0	22,0	-	80,0	28,0	12,0	44,5	-	M6	15.306.30.04.Z/80	30337202
30*	5,0	15,0	22,0	-	80,0	30,0	10,0	44,5	-	M6	15.306.30.05.Z/80	30337203
30*	6,0	21,0	27,0	-	80,0	36,0	10,0	38,1	-	M5	15.306.30.06.Z/80	30337204
30*	8,0	21,0	27,0	-	80,0	36,0	10,0	38,1	-	M6	15.306.30.08.Z/80	30337205
30*	10,0	24,0	32,0	-	80,0	41,0	10,0	50,8	-	M8x1	15.306.30.10.Z/80	30337206
30*	12,0	24,0	32,0	-	80,0	47,0	10,0	50,8	-	M10x1	15.306.30.12.Z/80	30337207
30*	14,0	27,0	34,0	-	80,0	47,0	10,0	44,5	-	M10x1	15.306.30.14.Z/80	30337208
30*	16,0	27,0	34,0	-	80,0	50,0	10,0	44,5	-	M12x1	15.306.30.16.Z/80	30337209
30*	18,0	33,0	42,0	-	80,0	50,0	10,0	55,3	-	M12x1	15.306.30.18.Z/80	30337210
30*	20,0	33,0	42,0	-	80,0	52,0	10,0	55,3	-	M16x1	15.306.30.20.Z/80	30337211
40	3,0	10,0	17,0	-	80,0	28,0	16,0	44,5	-	M6	15.306.40.03.Z/80	30337097
40**	3,0	10,0	20,0	-	120,0	12,0	-	63,53	-	-	15.306.40.03.Z/120	30337212
40	4,0	15,0	22,0	-	80,0	28,0	12,0	44,5	-	M6	15.306.40.04.Z/80	30337098
40**	4,0	15,0	22,0	-	120,0	16,0	-	44,5	-	-	15.306.40.04.Z/120	30337214
40	5,0	15,0	22,0	-	80,0	30,0	10,0	44,5	-	M6	15.306.40.05.Z/80	30337099
40**	5,0	15,0	22,0	-	120,0	20,0	-	44,5	-	-	15.306.40.05.Z/120	30337216
40	6,0	21,0	27,0	-	80,0	36,0	10,0	38,1	-	M5	15.306.40.06.Z/80	30337100
40	6,0	21,0	27,0	-	120,0	36,0	10,0	38,1	-	M5	15.306.40.06.Z/120	30337218
40	6,0	21,0	27,0	-	160,0	36,0	10,0	38,1	-	M5	15.306.40.06.Z/160	30337219
40	6,0	21,0	27,0	-	200,0	36,0	10,0	38,1	-	M5	15.306.40.06.Z/200	30562525
40	8,0	21,0	27,0	-	80,0	36,0	10,0	38,1	-	M6	15.306.40.08.Z/80	30337102
40	8,0	21,0	27,0	-	120,0	36,0	10,0	38,1	-	M6	15.306.40.08.Z/120	30337220
40	8,0	21,0	27,0	-	160,0	36,0	10,0	38,1	-	M6	15.306.40.08.Z/160	30337221
40	8,0	21,0	27,0	-	200,0	36,0	10,0	38,1	-	M6	15.306.40.08.Z/200	30562526
40	10,0	24,0	32,0	-	80,0	41,0	10,0	50,8	-	M8x1	15.306.40.10.Z/80	30337104
40	10,0	24,0	32,0	-	120,0	41,0	10,0	50,8	-	M8x1	15.306.40.10.Z/120	30337222
40	10,0	24,0	32,0	-	160,0	41,0	10,0	50,8	-	M8x1	15.306.40.10.Z/160	30337223
40	10,0	24,0	32,0	-	200,0	41,0	10,0	50,8	-	M8x1	15.306.40.10.Z/200	30562527
40	12,0	24,0	32,0	-	80,0	47,0	10,0	50,8	-	M10x1	15.306.40.12.Z/80	30337106
40	12,0	24,0	32,0	-	120,0	47,0	10,0	50,8	-	M10x1	15.306.40.12.Z/120	30337224
40	12,0	24,0	32,0	-	160,0	47,0	10,0	50,8	-	M10x1	15.306.40.12.Z/160	30337225
40	12,0	24,0	32,0	-	200,0	47,0	10,0	50,8	-	M10x1	15.306.40.12.Z/200	30337226
40	14,0	27,0	34,0	-	80,0	47,0	10,0	44,5	-	M10x1	15.306.40.14.Z/80	30337108
40	14,0	27,0	34,0	-	120,0	47,0	10,0	44,5	-	M10x1	15.306.40.14.Z/120	30337227
40	14,0	27,0	34,0	-	160,0	47,0	10,0	44,5	-	M10x1	15.306.40.14.Z/160	30337228
40	14,0	27,0	34,0	-	200,0	47,0	10,0	44,5	-	M10x1	15.306.40.14.Z/200	30562530
40	16,0	27,0	34,0	-	80,0	50,0	10,0	44,5	-	M12x1	15.306.40.16.Z/80	30337110
40	16,0	27,0	34,0	-	120,0	50,0	10,0	44,5	-	M12x1	15.306.40.16.Z/120	30337229

Shrink chuck ISO 7388-1, Form AD | Preferred series available from stock

Steep taper	Dimensions									G	Order designation	Order no.
	d ₁	d ₂	d ₃	d ₄	l ₁	l ₂	l ₃	l ₄	l ₅			
40	16,0	27,0	34,0	-	160,0	50,0	10,0	44,5	-	M12x1	15.306.40.16.Z/160	30337230
40	16,0	27,0	34,0	-	200,0	50,0	10,0	44,5	-	M12x1	15.306.40.16.Z/200	30562531
40	18,0	33,0	42,0	-	80,0	50,0	10,0	52,45	-	M12x1	15.306.40.18.Z/80	30337111
40	18,0	33,0	42,0	-	120,0	50,0	10,0	57,2	-	M12x1	15.306.40.18.Z/120	30337231
40	18,0	33,0	42,0	-	160,0	50,0	10,0	57,2	-	M12x1	15.306.40.18.Z/160	30337232
40	18,0	33,0	42,0	-	200,0	50,0	10,0	57,2	-	M12x1	15.306.40.18.Z/200	30562534
40	20,0	33,0	42,0	-	80,0	52,0	10,0	52,65	-	M16x1	15.306.40.20.Z/80	30337112
40	20,0	33,0	42,0	-	120,0	52,0	10,0	57,2	-	M16x1	15.306.40.20.Z/120	30337233
40	20,0	33,0	42,0	-	160,0	52,0	10,0	57,2	-	M16x1	15.306.40.20.Z/160	30337234
40	20,0	33,0	42,0	-	200,0	52,0	10,0	57,2	-	M16x1	15.306.40.20.Z/200	30562535
40	25,0	44,0	49,0	53	100,0	58,0	10,0	57,2	63,5	M16x1	15.306.40.25.Z/100	30337113
40	25,0	44,0	53,0	49	120,0	58,0	10,0	57,2	63,5	M16x1	15.306.40.25.Z/120	30337235
40	25,0	44,0	53,0	49	160,0	58,0	10,0	57,2	63,5	M16x1	15.306.40.25.Z/160	30337236
40	25,0	44,0	53,0	49	200,0	58,0	10,0	57,2	63,5	M16x1	15.306.40.25.Z/200	30562536
40	32,0	44,0	49,0	53	100,0	62,0	10,0	57,2	63,5	M16x1	15.306.40.32.Z/100	30337114
40	32,0	44,0	53,0	49	120,0	62,0	10,0	57,2	63,5	M16x1	15.306.40.32.Z/120	30337237
40	32,0	44,0	53,0	49	160,0	62,0	10,0	57,2	63,5	M16x1	15.306.40.32.Z/160	30337238
40	32,0	44,0	53,0	49	200,0	62,0	10,0	57,2	63,5	M16x1	15.306.40.32.Z/200	30562537
50**	3,0	10,0	17,0	-	80,0	12,0	-	44,5	-	-	15.306.50.03.Z/80	30337239
50**	3,0	10,0	20,0	-	120,0	12,0	-	63,53	-	-	15.306.50.03.Z/120	30337240
50**	4,0	15,0	22,0	-	80,0	16,0	-	44,5	-	-	15.306.50.04.Z/80	30337242
50**	4,0	15,0	22,0	-	120,0	16,0	-	44,5	-	-	15.306.50.04.Z/120	30337243
50**	5,0	15,0	22,0	-	80,0	20,0	-	44,5	-	-	15.306.50.05.Z/80	30337245
50**	5,0	15,0	22,0	-	120,0	20,0	-	44,5	-	-	15.306.50.05.Z/120	30337246
50	6,0	21,0	27,0	-	80,0	36,0	10,0	38,1	-	M5	15.306.50.06.Z/80	30337248
50	6,0	21,0	27,0	-	120,0	36,0	10,0	38,1	-	M5	15.306.50.06.Z/120	30337249
50	6,0	21,0	27,0	-	160,0	36,0	10,0	38,1	-	M5	15.306.50.06.Z/160	30337250
50	8,0	21,0	27,0	-	80,0	36,0	10,0	38,1	-	M6	15.306.50.08.Z/80	30337251
50	8,0	21,0	27,0	-	120,0	36,0	10,0	38,1	-	M6	15.306.50.08.Z/120	30337252
50	8,0	21,0	27,0	-	160,0	36,0	10,0	38,1	-	M6	15.306.50.08.Z/160	30337253
50	10,0	24,0	32,0	-	80,0	41,0	10,0	50,8	-	M8x1	15.306.50.10.Z/80	30337254
50	10,0	24,0	32,0	-	120,0	41,0	10,0	50,8	-	M8x1	15.306.50.10.Z/120	30337255
50	10,0	24,0	32,0	-	160,0	41,0	10,0	50,8	-	M8x1	15.306.50.10.Z/160	30337256
50	12,0	24,0	32,0	-	80,0	47,0	10,0	50,8	-	M10x1	15.306.50.12.Z/80	30337257
50	12,0	24,0	32,0	-	120,0	47,0	10,0	50,8	-	M10x1	15.306.50.12.Z/120	30337258
50	12,0	24,0	32,0	-	160,0	47,0	10,0	50,8	-	M10x1	15.306.50.12.Z/160	30337259
50	14,0	27,0	34,0	-	80,0	47,0	10,0	44,5	-	M10x1	15.306.50.14.Z/80	30337260
50	14,0	27,0	34,0	-	120,0	47,0	10,0	44,5	-	M10x1	15.306.50.14.Z/120	30337261
50	14,0	27,0	34,0	-	160,0	47,0	10,0	44,5	-	M10x1	15.306.50.14.Z/160	30337262
50	16,0	27,0	34,0	-	80,0	50,0	10,0	44,5	-	M12x1	15.306.50.16.Z/80	30337263
50	16,0	27,0	34,0	-	120,0	50,0	10,0	44,5	-	M12x1	15.306.50.16.Z/120	30337264
50	16,0	27,0	34,0	-	160,0	50,0	10,0	44,5	-	M12x1	15.306.50.16.Z/160	30337265
50	18,0	33,0	42,0	-	80,0	50,0	10,0	55,3	-	M12x1	15.306.50.18.Z/80	30337266
50	18,0	33,0	42,0	-	120,0	50,0	10,0	57,2	-	M12x1	15.306.50.18.Z/120	30337267
50	18,0	33,0	42,0	-	160,0	50,0	10,0	57,2	-	M12x1	15.306.50.18.Z/160	30337268
50	20,0	33,0	42,0	-	80,0	52,0	10,0	55,3	-	M16x1	15.306.50.20.Z/80	30337269

Shrink chuck ISO 7388-1, Form AD | Preferred series available from stock

Steep taper	Dimensions									G	Order designation	Order no.
	d ₁	d ₂	d ₃	d ₄	l ₁	l ₂	l ₃	l ₄	l ₅			
50	20,0	33,0	42,0	-	120,0	52,0	10,0	57,2	-	M16x1	15.306.50.20.Z/120	30337270
50	20,0	33,0	42,0	-	160,0	52,0	10,0	57,2	-	M16x1	15.306.50.20.Z/160	30337271
50	25,0	44,0	53,0	-	100,0	58,0	10,0	57,2	-	M16x1	15.306.50.25.Z/100	30337272
50	25,0	44,0	53,0	-	120,0	58,0	10,0	57,2	-	M16x1	15.306.50.25.Z/120	30337273
50	25,0	44,0	53,0	-	160,0	58,0	10,0	57,2	-	M16x1	15.306.50.25.Z/160	30337274
50	32,0	44,0	53,0	-	100,0	62,0	10,0	57,2	-	M16x1	15.306.50.32.Z/100	30337275
50	32,0	44,0	53,0	-	120,0	62,0	10,0	57,2	-	M16x1	15.306.50.32.Z/120	30337276
50	32,0	44,0	53,0	-	160,0	62,0	10,0	57,2	-	M16x1	15.306.50.32.Z/160	30337277

* design: Taper shank is not available in the AD/AF combination design

** Without axial tool length adjustment

Dimensions in mm.

For accessories and spare parts see "Accessories and spare parts" section.
Additional dimensions and special designs available upon request.

Shrink chuck

With axial tool length adjustment

Shank BT according to ISO 7388-2 Form JD/JF (JIS B 6339)

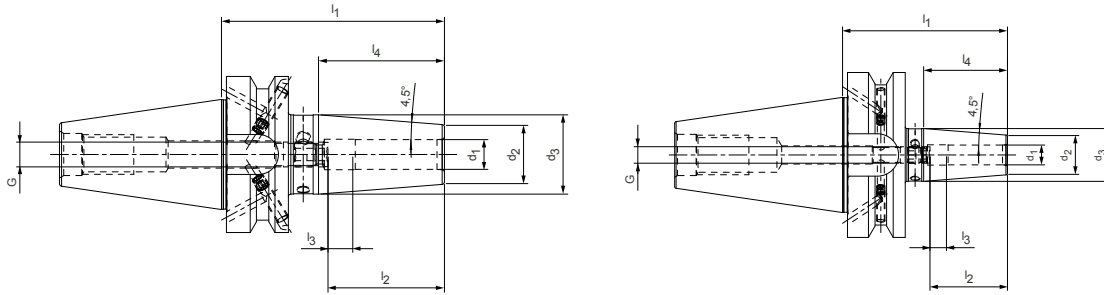

Preferred series available from stock

BT	Dimensions							G	Order designation	Order no.
	d ₁	d ₂	d ₃	l ₁	l ₂	l ₃	l ₄			
30*	3,0	10,0	17,0	85,0	28,0	16,0	44,5	M6	22.306.30.03.Z/85	30337666
30*	4,0	15,0	22,0	85,0	28,0	12,0	44,5	M6	22.306.30.04.Z/85	30337667
30*	5,0	15,0	22,0	85,0	30,0	10,0	44,5	M6	22.306.30.05.Z/85	30337668
30*	6,0	21,0	27,0	85,0	36,0	10,0	38,1	M5	22.306.30.06.Z/85	30337669
30*	8,0	21,0	27,0	85,0	36,0	10,0	38,1	M6	22.306.30.08.Z/85	30337670
30*	10,0	24,0	32,0	85,0	41,0	10,0	50,8	M8x1	22.306.30.10.Z/85	30337671
30*	12,0	24,0	32,0	85,0	47,0	10,0	50,8	M10x1	22.306.30.12.Z/85	30337672
30*	14,0	27,0	34,0	85,0	47,0	10,0	44,5	M10x1	22.306.30.14.Z/85	30337673
30*	16,0	27,0	34,0	85,0	50,0	10,0	44,5	M12x1	22.306.30.16.Z/85	30337674
30*	18,0	33,0	42,0	85,0	50,0	10,0	55,3	M12x1	22.306.30.18.Z/85	30337675
30*	20,0	33,0	42,0	85,0	52,0	10,0	55,3	M16x1	22.306.30.20.Z/85	30337676
40	3,0	10,0	17,0	90,0	28,0	16,0	44,5	M6	22.306.40.03.Z/90	30337677
40**	3,0	10,0	20,0	120,0	-	-	63,53	-	22.306.40.03.Z/120	30337678
40	4,0	15,0	22,0	90,0	28,0	12,0	44,5	M6	22.306.40.04.Z/90	30337680
40**	4,0	15,0	22,0	120,0	-	-	44,5	-	22.306.40.04.Z/120	30337681
40	5,0	15,0	22,0	90,0	30,0	10,0	44,5	M6	22.306.40.05.Z/90	30337683
40**	5,0	15,0	22,0	120,0	-	-	44,5	-	22.306.40.05.Z/120	30337684
40	6,0	21,0	27,0	90,0	36,0	10,0	38,1	M5	22.306.40.06.Z/90	30337686
40	6,0	21,0	27,0	120,0	36,0	10,0	38,1	M5	22.306.40.06.Z/120	30337687
40	6,0	21,0	27,0	160,0	36,0	10,0	38,1	M5	22.306.40.06.Z/160	30337688
40	8,0	21,0	27,0	90,0	36,0	10,0	38,1	M6	22.306.40.08.Z/90	30337690
40	8,0	21,0	27,0	120,0	36,0	10,0	38,1	M6	22.306.40.08.Z/120	30337691
40	8,0	21,0	27,0	160,0	36,0	10,0	38,1	M6	22.306.40.08.Z/160	30337692
40	10,0	24,0	32,0	90,0	41,0	10,0	50,8	M8x1	22.306.40.10.Z/90	30337694
40	10,0	24,0	32,0	120,0	41,0	10,0	50,8	M8x1	22.306.40.10.Z/120	30337695
40	10,0	24,0	32,0	160,0	41,0	10,0	50,8	M8x1	22.306.40.10.Z/160	30337696
40	12,0	24,0	32,0	90,0	47,0	10,0	50,8	M10x1	22.306.40.12.Z/90	30337699
40	12,0	24,0	32,0	120,0	47,0	10,0	50,8	M10x1	22.306.40.12.Z/120	30337700
40	12,0	24,0	32,0	160,0	47,0	10,0	50,8	M10x1	22.306.40.12.Z/160	30337701
40	14,0	27,0	34,0	90,0	47,0	10,0	44,5	M10x1	22.306.40.14.Z/90	30337703
40	14,0	27,0	34,0	120,0	47,0	10,0	44,5	M10x1	22.306.40.14.Z/120	30337704
40	14,0	27,0	34,0	160,0	47,0	10,0	44,5	M10x1	22.306.40.14.Z/160	30342696
40	16,0	27,0	34,0	90,0	50,0	10,0	44,5	M12x1	22.306.40.16.Z/90	30337706
40	16,0	27,0	34,0	120,0	50,0	10,0	44,5	M12x1	22.306.40.16.Z/120	30337707
40	16,0	27,0	34,0	160,0	50,0	10,0	44,5	M12x1	22.306.40.16.Z/160	30337708
40	18,0	33,0	42,0	90,0	50,0	10,0	55,3	M12x1	22.306.40.18.Z/90	30337709
40	18,0	33,0	42,0	120,0	50,0	10,0	57,2	M12x1	22.306.40.18.Z/120	30337710
40	18,0	33,0	42,0	160,0	50,0	10,0	57,2	M12x1	22.306.40.18.Z/160	30337711
40	20,0	33,0	42,0	90,0	52,0	10,0	55,3	M16x1	22.306.40.20.Z/90	30337712

Shrink chuck ISO 7388-2 (JIS B6339) | With coolant supply according to ISO 7388-2, Form JD | Preferred series available from stock

BT	Dimensions							G	Order designation	Order no.
	d ₁	d ₂	d ₃	l ₁	l ₂	l ₃	l ₄			
40	20,0	33,0	42,0	120,0	52,0	10,0	57,2	M16x1	22.306.40.20.Z/120	30337713
40	20,0	33,0	42,0	160,0	52,0	10,0	57,2	M16x1	22.306.40.20.Z/160	30337714
40	25,0	44,0	53,0	100,0	58,0	10,0	57,2	M16x1	22.306.40.25.Z/100	30337715
40	25,0	44,0	53,0	120,0	58,0	10,0	57,2	M16x1	22.306.40.25.Z/120	30337716
40	25,0	44,0	53,0	160,0	58,0	10,0	57,2	M16x1	22.306.40.25.Z/160	30337717
40	32,0	44,0	53,0	100,0	62,0	10,0	57,2	M16x1	22.306.40.32.Z/100	30337718
40	32,0	44,0	53,0	120,0	62,0	10,0	57,2	M16x1	22.306.40.32.Z/120	30337719
40	32,0	44,0	53,0	160,0	62,0	10,0	57,2	M16x1	22.306.40.32.Z/160	30337720
50	6,0	21,0	27,0	100,0	36,0	10,0	38,1	M5	22.306.50.06.Z/100	30337730
50	8,0	21,0	27,0	100,0	36,0	10,0	38,1	M6	22.306.50.08.Z/100	30337733
50	10,0	24,0	32,0	100,0	41,0	10,0	50,8	M8x1	22.306.50.10.Z/100	30337736
50	12,0	24,0	32,0	100,0	47,0	10,0	50,8	M10x1	22.306.50.12.Z/100	30337739
50	14,0	27,0	34,0	100,0	47,0	10,0	44,5	M10x1	22.306.50.14.Z/100	30337742
50	16,0	27,0	34,0	100,0	50,0	10,0	44,5	M12x1	22.306.50.16.Z/100	30337745
50	18,0	33,0	42,0	100,0	50,0	10,0	55,3	M12x1	22.306.50.18.Z/100	30337748
50	20,0	33,0	42,0	100,0	52,0	10,0	55,3	M16x1	22.306.50.20.Z/100	30337751
50	25,0	44,0	53,0	110,0	58,0	10,0	57,2	M16x1	22.306.50.25.Z/110	30337754
50	32,0	44,0	53,0	110,0	62,0	10,0	57,2	M16x1	22.306.50.32.Z/110	30337757

* Design: Taper shank is not available in the AD/AF combination design

** Without axial tool length adjustment

Dimensions in mm.

For accessories and spare parts see "Accessories and spare parts" section.
Additional dimensions and special designs available upon request.

Shrink chuck

With axial tool length adjustment

Shank similar to ISO 7388-2 Form JD (with face connection)

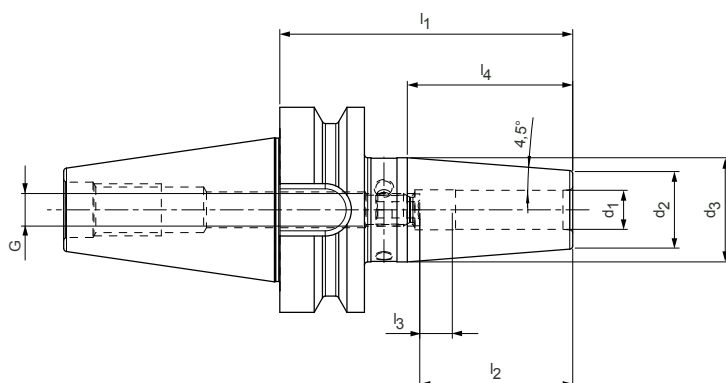

Preferred series available from stock

BT-FC	Dimensions							G	Order designation	Order no.
	d ₁	d ₂	d ₃	l ₁	l ₂	l ₃	l ₄			
30	3,0	10,0	17,0	85,0	28,0	16,0	44,5	M6	27.306.30.03.Z/85	30660169
30	4,0	15,0	22,0	85,0	28,0	12,0	44,5	M6	27.306.30.04.Z/85	30660172
30	5,0	15,0	22,0	85,0	30,0	10,0	44,5	M6	27.306.30.05.Z/85	30660173
30	6,0	21,0	27,0	85,0	36,0	10,0	38,1	M5	27.306.30.06.Z/85	30660174
30	8,0	21,0	27,0	85,0	36,0	10,0	38,1	M6	27.306.30.08.Z/85	30660175
30	10,0	24,0	32,0	85,0	41,0	10,0	50,8	M8x1	27.306.30.10.Z/85	30660176
30	12,0	24,0	32,0	85,0	47,0	10,0	50,8	M10x1	27.306.30.12.Z/85	30660177
30	14,0	27,0	34,0	85,0	47,0	10,0	44,5	M10x1	27.306.30.14.Z/85	30660178
30	16,0	27,0	34,0	85,0	50,0	10,0	44,5	M12x1	27.306.30.16.Z/85	30660179
30	18,0	33,0	42,0	85,0	50,0	10,0	55,3	M12x1	27.306.30.18.Z/85	30660180
30	20,0	33,0	42,0	85,0	52,0	10,0	55,3	M16x1	27.306.30.20.Z/85	30660181
40	3,0	10,0	17,0	90,0	28,0	16,0	44,5	M6	27.306.40.03.Z/90	30660182
40	4,0	15,0	22,0	90,0	28,0	12,0	44,5	M6	27.306.40.04.Z/90	30660183
40	5,0	15,0	22,0	90,0	30,0	10,0	44,5	M6	27.306.40.05.Z/90	30660184
40	6,0	21,0	27,0	90,0	36,0	10,0	38,1	M5	27.306.40.06.Z/90	30660185
40	8,0	21,0	27,0	90,0	36,0	10,0	38,1	M6	27.306.40.08.Z/90	30660186
40	10,0	24,0	32,0	90,0	41,0	10,0	50,8	M8x1	27.306.40.10.Z/90	30660187
40	12,0	24,0	32,0	90,0	47,0	10,0	50,8	M10x1	27.306.40.12.Z/90	30660188
40	14,0	27,0	34,0	90,0	47,0	10,0	44,5	M10x1	27.306.40.14.Z/90	30660189
40	16,0	27,0	34,0	90,0	50,0	10,0	44,5	M12x1	27.306.40.16.Z/90	30660190
40	18,0	33,0	42,0	90,0	50,0	10,0	55,3	M12x1	27.306.40.18.Z/90	30660191
40	20,0	33,0	42,0	90,0	52,0	10,0	55,3	M16x1	27.306.40.20.Z/90	30660192
40	25,0	44,0	53,0	100,0	58,0	10,0	57,2	M16x1	27.306.40.25.Z/100	30660193
40	32,0	44,0	53,0	100,0	62,0	10,0	57,2	M16x1	27.306.40.32.Z/100	30660194

Dimensions in mm.

For accessories and spare parts see "Accessories and spare parts" section.

Additional dimensions and special designs available upon request.

Shrink chuck

With radial and angular alignment and axial tool length adjustment
Module connection sizes in accordance with MN5000-14

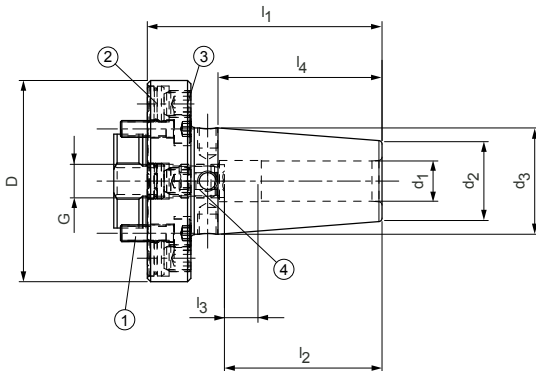

Preferred series available from stock

Mounting diameter module D	Dimensions							G	Order designation	Order no.
	d ₁	d ₂	d ₃	l ₁	l ₂	l ₃	l ₄			
60	6,0	21,0	27,0	70,0	36,0	10,0	38,1	M5	68.306.60.06.Z/70	30559449
60	8,0	21,0	27,0	70,0	36,0	10,0	38,1	M6	68.306.60.08.Z/70	30559531
60	10,0	24,0	32,0	70,0	41,0	10,0	48,9	M8x1	68.306.60.10.Z/70	30559536
60	12,0	24,0	32,0	70,0	47,0	10,0	48,9	M10x1	68.306.60.12.Z/70	30559537
70	14,0	27,0	34,0	75,0	47,0	10,0	44,5	M10x1	68.306.70.14.Z/75	30559543
70	16,0	27,0	34,0	75,0	50,0	10,0	44,5	M12x1	68.306.70.16.Z/75	30559544
80	18,0	33,0	42,0	80,0	50,0	10,0	55,3	M12x1	68.306.80.18.Z/80	30559545
80	20,0	33,0	42,0	80,0	52,0	10,0	55,3	M16x1	68.306.80.20.Z/80	30559547
100	25,0	44,0	53,0	80,0	58,0	10,0	56,5	M16x1	68.306.100.25.Z/80	30559548
100	32,0	44,0	53,0	80,0	62,0	10,0	56,5	M16x1	68.306.100.32.Z/80	30559551

Spare parts for shrink chucks with radial and angular alignment

Module diameter D	Quantity required	Cylinder head screw in accordance with ISO 4762		Thrust pad		Threaded pin	
		Size	Order no.	Order designation	Order no.	Order designation	Order no.
60	4	M5x16 – 12.9	10003601	ø10.6x5	10040108	M8x1x8	10040109
70	4	M6x20 – 12.9	10003619	ø10.6x5	10040108	M8x1x8	10040109
80	4	M6x20 – 12.9	10003619	ø10.6x5	10040108	M8x1x11.5	10075074
100	4	M8x25 – 12.9	10003637	ø12.8x5	10075116	M10x1x14	10075100

Module diameter D	Order designation	④ Length adjustment screw	
		Order designation	Order no.
60	68.306.60.06.Z/70	M5x16-45H	10049051
60	68.306.60.08.Z/70	M6x16-45H	10049052
60	68.306.60.10.Z/70	M8x1x16-45H	10049053
60	68.306.60.12.Z/70	M10x1x18-45H	10049056
70	68.306.70.14.Z/75	M10x1x18-45H	10049056
70	68.306.70.16.Z/75	M12x1x18-45H	10049059
80	68.306.80.18.Z/80	M12x1x18-45H	10049059
80	68.306.80.20.Z/80	M16x1x18-45H	10067787
100	68.306.100.25.Z/80	M16x1x22-45H	10067681
100	68.306.100.32.Z/80	M16x1x22-45H	10067681

Dimensions in mm.

For accessories and spare parts see "Accessories and spare parts" section.
Additional dimensions and special designs available upon request.

Shrink chuck

With axial tool length adjustment

HSK-A (hollow shank taper form A) shank according to DIN 69893-1

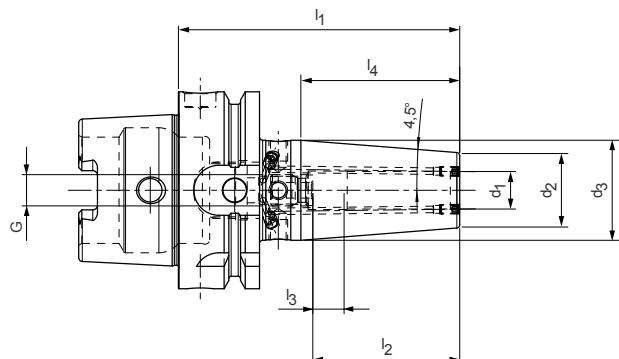

Design with two cooling channel outlets, resealable | Preferred series available from stock

HSK-A	Dimensions							G	Order designation	Order no.
	d ₁	d ₂	d ₃	l ₁	l ₂	l ₃	l ₄			
63	3,0	10,0	15,0	80,0	28,0	16,0	31,77	M6	16.306.63.03.KKB/80	30590796
63*	3,0	10,0	20,0	120,0	12,0	-	63,53	-	16.306.63.03.KKB/120	30590800
63	4,0	15,0	22,0	80,0	28,0	12,0	44,5	M6	16.306.63.04.KKB/80	30590797
63*	4,0	15,0	22,0	120,0	16,0	-	44,5	-	16.306.63.04.KKB/120	30590801
63	5,0	15,0	22,0	80,0	30,0	10,0	44,5	M6	16.306.63.05.KKB/80	30590798
63*	5,0	15,0	22,0	120,0	20,0	-	44,5	-	16.306.63.05.KKB/120	30590802
63	6,0	21,0	27,0	80,0	36,0	10,0	38,1	M5	16.306.63.06.KKB/80	30589885
63	6,0	21,0	27,0	120,0	36,0	10,0	38,1	M5	16.306.63.06.KKB/120	30589886
63	8,0	21,0	27,0	80,0	36,0	10,0	38,1	M6	16.306.63.08.KKB/80	30589886
63	8,0	21,0	27,0	120,0	36,0	10,0	38,1	M6	16.306.63.08.KKB/120	30589899
63	10,0	24,0	32,0	85,0	41,0	10,0	49,0	M8x1	16.306.63.10.KKB/85	30589887
63	10,0	24,0	32,0	120,0	41,0	10,0	49,0	M8x1	16.306.63.10.KKB/120	30589900
63	12,0	24,0	32,0	90,0	47,0	10,0	49,0	M10x1	16.306.63.12.KKB/90	30589888
63	12,0	24,0	32,0	120,0	47,0	10,0	49,0	M10x1	16.306.63.12.KKB/120	30589901
63	14,0	27,0	34,0	90,0	47,0	10,0	44,5	M10x1	16.306.63.14.KKB/90	30589889
63	14,0	27,0	34,0	120,0	47,0	10,0	44,5	M10x1	16.306.63.14.KKB/120	30589902
63	16,0	27,0	34,0	95,0	50,0	10,0	44,5	M12x1	16.306.63.16.KKB/95	30589890
63	16,0	27,0	34,0	120,0	50,0	10,0	44,5	M12x1	16.306.63.16.KKB/120	30589907
63	18,0	33,0	42,0	95,0	50,0	10,0	57,2	M12x1	16.306.63.18.KKB/95	30589891
63	18,0	33,0	42,0	120,0	50,0	10,0	57,2	M12x1	16.306.63.18.KKB/120	30589908
63	20,0	33,0	42,0	100,0	52,0	10,0	57,2	M16x1	16.306.63.20.KKB/100	30589892
63	20,0	33,0	42,0	120,0	52,0	10,0	57,2	M16x1	16.306.63.20.KKB/120	30589909
63	25,0	44,0	52,5	115,0	58,0	10,0	54,0	M16x1	16.306.63.25.KKB/115	30589894
63	25,0	44,0	52,5	120,0	58,0	10,0	54,0	M16x1	16.306.63.25.KKB/120	30589910
63	32,0	44,0	52,5	120,0	62,0	10,0	54,0	M16x1	16.306.63.32.KKB/120	30589895

* Without axial tool length adjustment

Dimensions in mm.

For accessories and spare parts see "Accessories and spare parts" section.

Additional dimensions and special designs available upon request.

Shrink chuck

Reinforced design, with axial tool length adjustment

HSK-A (hollow shank taper form A) shank according to DIN 69893-1

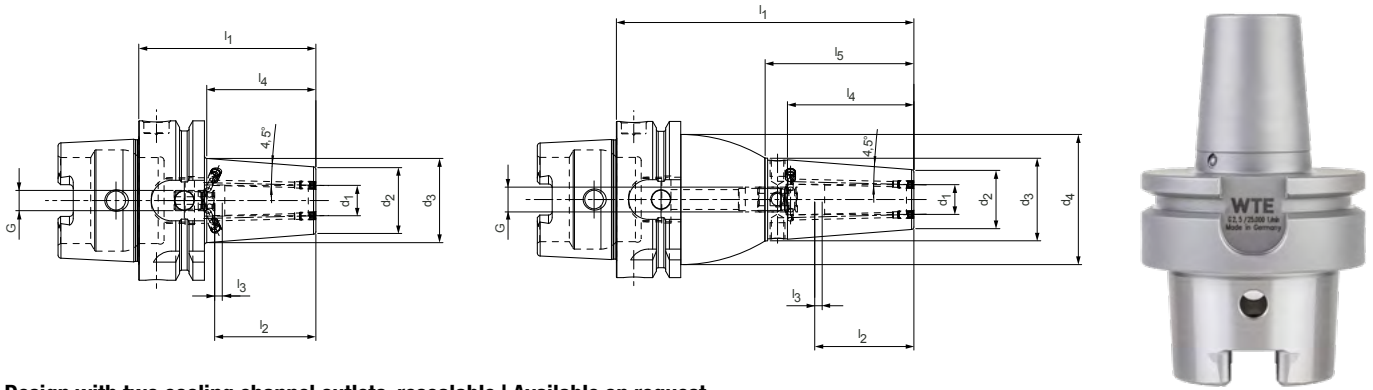

Design with two cooling channel outlets, resealable | Available on request

HSK-A	Dimensions									G	Order designation	Order no.
	d ₁	d ₂	d ₃	d ₄	l ₁	l ₂	l ₃	l ₄	l ₅			
63	6,0	22,0	28,8	-	70,0	36,0	10,0	43,1	-	M5	16.307.63.06.KKB/70	30655242
63	6,0	21,0	29,0	52,5	120,0	36,0	10,0	42,0	51,0	M5	16.307.63.06.KKB/120	30655250
63	8,0	22,0	28,8	-	70,0	36,0	10,0	43,1	-	M6	16.307.63.08.KKB/70	30655243
63	8,0	21,0	29,0	52,5	120,0	36,0	10,0	42,0	51,0	M6	16.307.63.08.KKB/120	30655251
63	10,0	26,5	33,3	-	70,0	36,0	5,0	43,1	-	M8x1	16.307.63.10.KKB/70	30655244
63	10,0	24,0	32,7	52,5	120,0	41,0	10,0	46,0	55,0	M8x1	16.307.63.10.KKB/120	30655252
63	12,0	26,5	33,3	-	70,0	40,0	3,0	43,1	-	M8x1	16.307.63.12.KKB/70	30655245
63	12,0	24,0	33,4	52,5	120,0	47,0	10,0	51,0	60,0	M10x1	16.307.63.12.KKB/120	30655253
63	16,0	29,5	37,1	-	75,0	45,0	5,0	48,1	-	M8x1	16.307.63.16.KKB/75	30655246
63	16,0	27,0	36,9	52,5	120,0	50,0	10,0	54,0	63,0	M12x1	16.307.63.16.KKB/120	30655254
63	20,0	35,5	43,1	-	75,0	45,0	3,0	48,1	-	M8x1	16.307.63.20.KKB/75	30655247
63	20,0	33,0	43,2	52,5	120,0	52,0	10,0	56,0	65,0	M16x1	16.307.63.20.KKB/120	30655255
63	25,0	45,0	52,5	-	85,0	53,0	5,0	47,65	-	M8x1	16.307.63.25.KKB/85	30655248
63	25,0	44,0	52,5	-	120,0	58,0	10,0	54,0	-	M16x1	16.307.63.25.KKB/120	30655256
63	32,0	45,0	52,5	-	85,0	55,0	3,0	47,65	-	M8x1	16.307.63.32.KKB/85	30655249
63	32,0	44,0	52,5	-	120,0	62,0	10,0	54,0	-	M16x1	16.307.63.32.KKB/120	30655257

Dimensions in mm.

For accessories and spare parts see "Accessories and spare parts" section.

Additional dimensions and special designs available upon request.

Shrink chuck

With axial tool length adjustment

SK shank according to ISO 7388-1 Form AD/AF

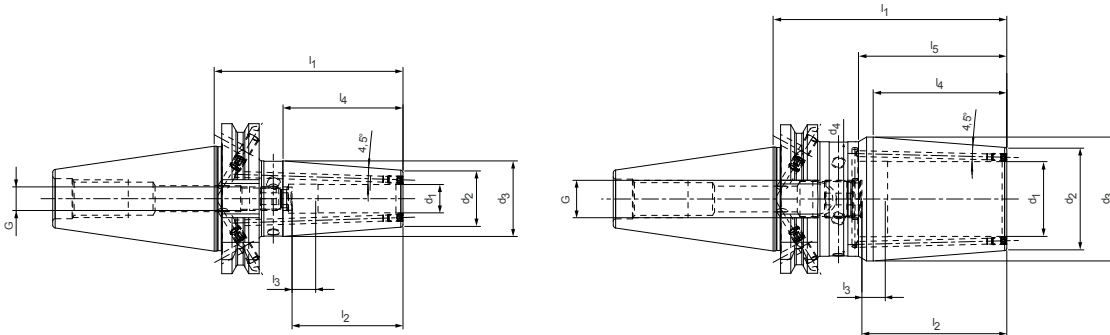

Design with two cooling channel outlets, resealable | Preferred series available from stock

Steep taper	Dimensions									G	Order designation	Order no.
	d ₁	d ₂	d ₃	d ₄	l ₁	l ₂	l ₃	l ₄	l ₅			
40	3,0	10,0	17,0	-	80,0	28,0	16,0	44,5	-	M6	15.306.40.03.KKB/80	30590786
40*	3,0	10,0	20,0	-	120,0	12,0	-	63,53	-	-	15.306.40.03.KKB/120	30590790
40	4,0	15,0	22,0	-	80,0	28,0	12,0	44,5	-	M6	15.306.40.04.KKB/80	30590787
40*	4,0	15,0	22,0	-	120,0	16,0	-	44,5	-	-	15.306.40.04.KKB/120	30590793
40	5,0	15,0	22,0	-	80,0	30,0	10,0	44,5	-	M6	15.306.40.05.KKB/80	30590789
40*	5,0	15,0	22,0	-	120,0	20,0	-	44,5	-	-	15.306.40.05.KKB/120	30590794
40	6,0	21,0	27,0	-	80,0	36,0	10,0	38,1	-	M5	15.306.40.06.KKB/80	30589845
40	6,0	21,0	27,0	-	120,0	36,0	10,0	38,1	-	M5	15.306.40.06.KKB/120	30589873
40	8,0	21,0	27,0	-	80,0	36,0	10,0	38,1	-	M6	15.306.40.08.KKB/80	30589849
40	8,0	21,0	27,0	-	120,0	36,0	10,0	38,1	-	M6	15.306.40.08.KKB/120	30589874
40	10,0	24,0	32,0	-	80,0	41,0	10,0	50,8	-	M8x1	15.306.40.10.KKB/80	30589850
40	10,0	24,0	32,0	-	120,0	41,0	10,0	50,8	-	M8x1	15.306.40.10.KKB/120	30589875
40	12,0	24,0	32,0	-	80,0	47,0	10,0	50,8	-	M10x1	15.306.40.12.KKB/80	30589852
40	12,0	24,0	32,0	-	120,0	47,0	10,0	50,8	-	M10x1	15.306.40.12.KKB/120	30589876
40	14,0	27,0	34,0	-	80,0	47,0	10,0	44,5	-	M10x1	15.306.40.14.KKB/80	30589853
40	14,0	27,0	34,0	-	120,0	47,0	10,0	44,5	-	M10x1	15.306.40.14.KKB/120	30589877
40	16,0	27,0	34,0	-	80,0	50,0	10,0	44,5	-	M12x1	15.306.40.16.KKB/80	30589855
40	16,0	27,0	34,0	-	120,0	50,0	10,0	44,5	-	M12x1	15.306.40.16.KKB/120	30589879
40	18,0	33,0	42,0	-	80,0	50,0	10,0	58,95	-	M12x1	15.306.40.18.KKB/80	30589857
40	18,0	33,0	42,0	-	120,0	50,0	10,0	57,2	-	M12x1	15.306.40.18.KKB/120	30589880
40	20,0	33,0	42,0	-	80,0	52,0	10,0	59,15	-	M16x1	15.306.40.20.KKB/80	30589858
40	20,0	33,0	42,0	-	120,0	52,0	10,0	57,2	-	M16x1	15.306.40.20.KKB/120	30589881
40	25,0	44,0	53,0	49,0	100,0	58,0	10,0	60	63,5	M16x1	15.306.40.25.KKB/100	30589870
40	25,0	44,0	53,0	49,0	120,0	58,0	10,0	60	63,5	M16x1	15.306.40.25.KKB/120	30589882
40	32,0	44,0	53,0	49,0	100,0	62,0	10,0	60	63,5	M16x1	15.306.40.32.KKB/100	30589872
40	32,0	44,0	53,0	49,0	120,0	62,0	10,0	60	63,5	M16x1	15.306.40.32.KKB/120	30589883

* Without axial tool length adjustment

Dimensions in mm.

For accessories and spare parts see "Accessories and spare parts" section.
Additional dimensions and special designs available upon request.

Shrink chuck

With axial tool length adjustment

Shank hollow shank taper E according to DIN 69893-5

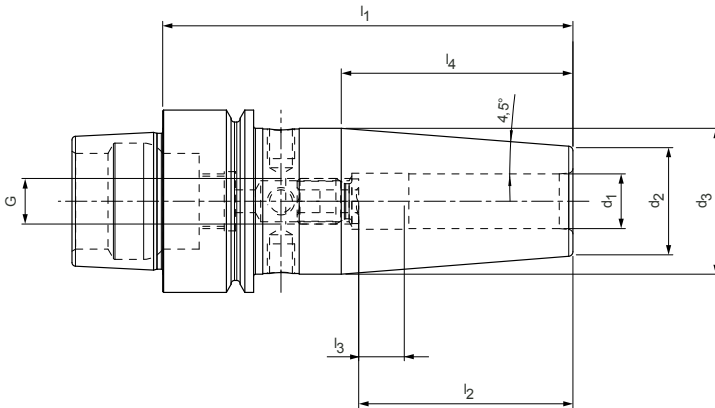

Available on request

HSK-E	Dimensions							G	Order designation	Order no.
	d ₁	d ₂	d ₃	l ₁	l ₂	l ₃	l ₄			
40	3,0	10,0	15,0	60,0	28,0	16,0	31,77	M6	18.306.40.03.Z/60	30337547
40	4,0	10,0	15,0	60,0	28,0	12,0	31,77	M6	18.306.40.04.Z/60	30337550
40	5,0	10,0	15,0	60,0	30,0	10,0	31,77	M6	18.306.40.05.Z/60	30337553
40	6,0	21,0	27,0	80,0	36,0	10,0	38,1	M5	18.306.40.06.Z/80	30337556
40	8,0	21,0	27,0	80,0	36,0	10,0	38,1	M6	18.306.40.08.Z/80	30337559
40	10,0	24,0	32,0	80,0	41,0	10,0	50,0	M8x1	18.306.40.10.Z/80	30337562
40	12,0	24,0	32,0	90,0	47,0	10,0	50,8	M10x1	18.306.40.12.Z/90	30337565
40	14,0	27,0	33,5	90,0	47,0	10,0	41,3	M10x1	18.306.40.14.Z/90	30337568
40	16,0	27,0	33,5	90,0	50,0	10,0	41,3	M12x1	18.306.40.16.Z/90	30337571
50	3,0	10,0	15,0	80,0	28,0	16,0	31,77	M6	18.306.50.03.Z/80	30337574
50	4,0	15,0	22,0	80,0	28,0	12,0	44,5	M6	18.306.50.04.Z/80	30337577
50	5,0	15,0	22,0	80,0	30,0	10,0	44,5	M6	18.306.50.05.Z/80	30337580
50	6,0	21,0	27,0	80,0	36,0	10,0	38,1	M5	18.306.50.06.Z/80	30337583
50	8,0	21,0	27,0	80,0	36,0	10,0	38,1	M6	18.306.50.08.Z/80	30337586
50	10,0	24,0	32,0	85,0	41,0	10,0	49,0	M8x1	18.306.50.10.Z/85	30337589
50	12,0	24,0	32,0	90,0	47,0	10,0	50,8	M10x1	18.306.50.12.Z/90	30337592
50	14,0	27,0	34,0	90,0	47,0	10,0	44,5	M10x1	18.306.50.14.Z/90	30337595
50	16,0	27,0	34,0	95,0	50,0	10,0	44,5	M12x1	18.306.50.16.Z/95	30337598
50	18,0	33,0	42,0	95,0	50,0	10,0	57,2	M12x1	18.306.50.18.Z/95	30337601
50	20,0	33,0	42,0	100,0	52,0	10,0	57,2	M16x1	18.306.50.20.Z/100	30337604

Dimensions in mm.

For accessories and spare parts see "Accessories and spare parts" section.

Additional dimensions and special designs available upon request.





MECHANICAL TOOL CLAMPING TECHNOLOGY

Chucks for cylindrical shanks

MillChuck, HB 74

Precision drill chuck

CNC precision drill chucks 78

Standard NC drill chucks 101

MICRO universal chuck 104

MillChuck, HB

Mill chuck for high-performance milling operations

The new side lock chuck from WTE impresses with its reliable clamping ability, easy handling and significantly improved radial run-out. The clamping bore is therefore manufactured with significantly more precision. This reduces the radial play of the clamped tool and considerably improves the radial run-out. The large tolerance on the lateral clamping surface is also compensated for.

To achieve this, WTE uses a spring element in the connection that enables a defined form fit between the tool and connection. Coolant channels parallel to the axis in the clamping range also ensure improved coolant supply.

A two-part clamping element is used to considerably simplify handling. This reduces the tightening torque while maintaining the same clamping force, allowing the tool to be clamped in the connection with manual force in a process-reliable manner.

AT A GLANCE

- Significantly precision clamping bore
- Available with clamping diameters from 6 to 32 mm for hollow shank taper form A (HSK-A) and steep taper (SK)
- Balancing quality of G 2.5 at 16,000 rpm
- Can be easily combined with WTE high-performance milling cutters

ADVANTAGES

- Easy to handle thanks to a differential screw
- Maximum cost-effectiveness and precision
- Axial tool positioning can be defined using a spring system
- Decentralised coolant outlets for maximum process reliability



Tool features in detail

1 Decentralised coolant supply channels

- Optimum coolant supply

2 Differential screw

- Easy to handle

3 Spring package

- Perfect connection to the HB clamping surface

4 Contour

- Application-optimised contour for maximum rigidity

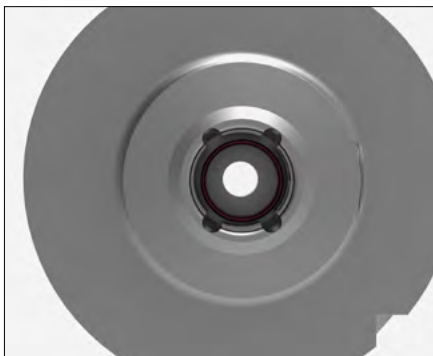
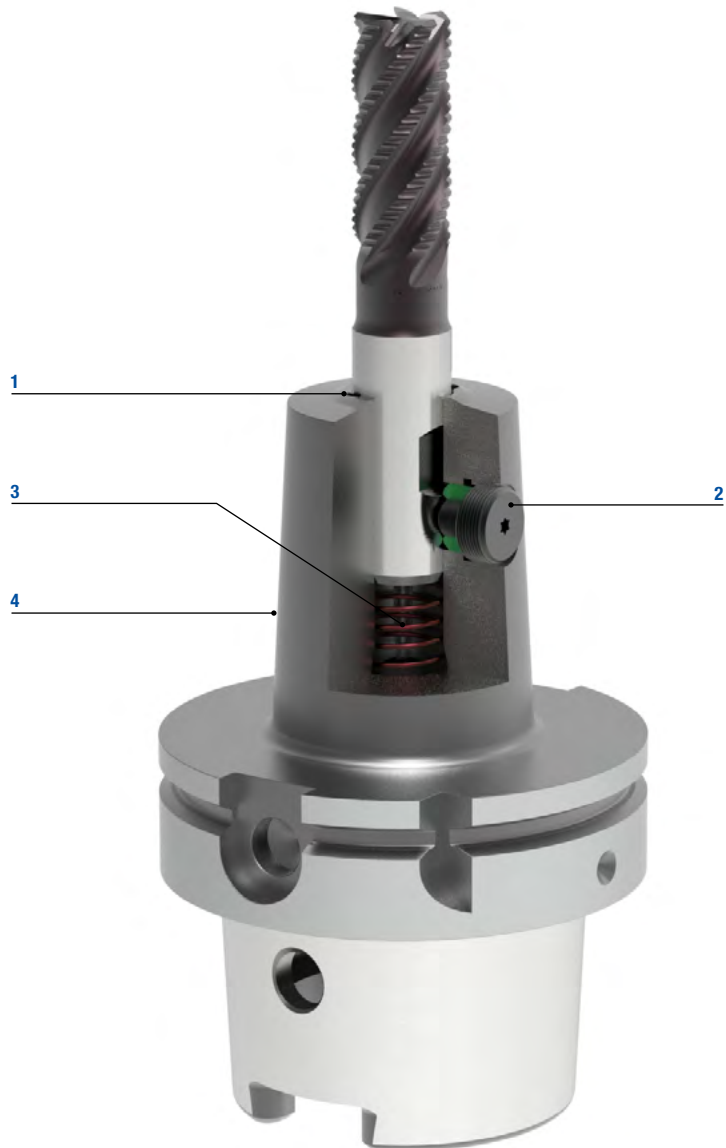

Optimal coolant supply

- Decentralised coolant supply channels
- Use of standard tools without internal cooling
- Tool life improved thanks to optimal cooling



Process-reliable tool clamping

- High clamping force thanks to two-part clamping element
- Differential screw for reduced tightening torque
- Process-reliable clamping through self-locking

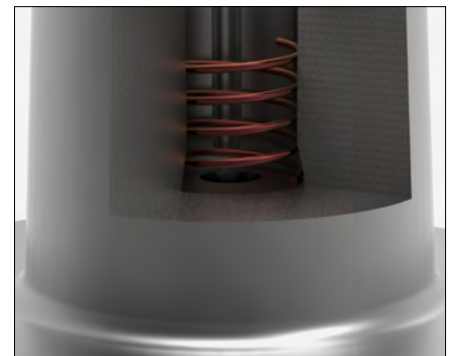

Defined milling cutter positioning

- Perfect connection to the HB clamping surface
- Form fit between tool and connection
- Prevents any pull-out during machining

MillChuck HB

Without tool length adjustment

HSK-A (hollow shank taper form A) shank according to DIN 69893-1

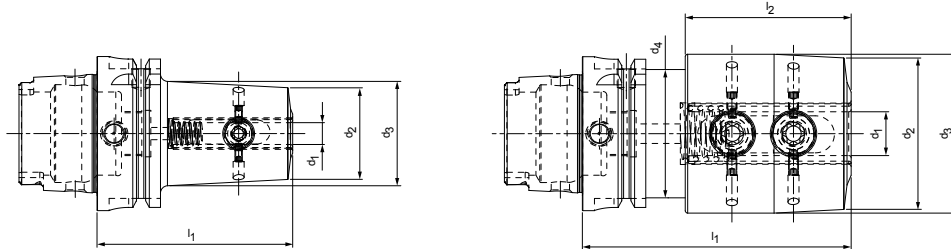

Preferred series available from stock

HSK-A	Dimensions						Order designation	Order no.
	d ₁	d ₂	d ₃	d ₄	l ₁	l ₂		
63	6,0	22,5	26,2	-	65,0	-	16.256.63.06.Z/65	31090556
63	8,0	25,0	28,7	-	65,0	-	16.256.63.08.Z/65	31090470
63	10,0	32,0	36,2	-	70,0	-	16.256.63.10.Z/70	31090471
63	12,0	37,5	42,7	-	80,0	-	16.256.63.12.Z/80	31090472
63	16,0	43,0	48,3	-	80,0	-	16.256.63.16.Z/80	31090474
63	20,0	46,5	52,0	-	80,0	-	16.256.63.20.Z/80	31090476
63	25,0	62,0	65,0	52,5	110,0	68,0	16.256.63.25.Z/110	31090477
63	32,0	69,0	72,0	52,5	110,0	68,0	16.256.63.32.Z/110	31090478
100	6,0	22,5	27,5	-	80,0	-	16.256.100.06.Z/80	31090479
100	8,0	25,0	30,0	-	80,0	-	16.256.100.08.Z/80	31090480
100	10,0	32,0	36,9	-	80,0	-	16.256.100.10.Z/80	31090481
100	12,0	37,5	42,9	-	85,0	-	16.256.100.12.Z/85	31090482
100	16,0	43,0	50,0	-	100,0	-	16.256.100.16.Z/100	31090484
100	20,0	46,5	53,5	-	100,0	-	16.256.100.20.Z/100	31090486
100	25,0	62,0	65,0	-	100,0	-	16.256.100.25.Z/100	31090487
100	32,0	69,0	72,0	-	110,0	-	16.256.100.32.Z/110	31090488

Dimensions in mm.

For accessories and spare parts see "Accessories and spare parts" section.

Additional dimensions and special designs available upon request.

MillChuck HB

Without tool length adjustment

SK shank according to ISO 7388-1 Form AD/AF

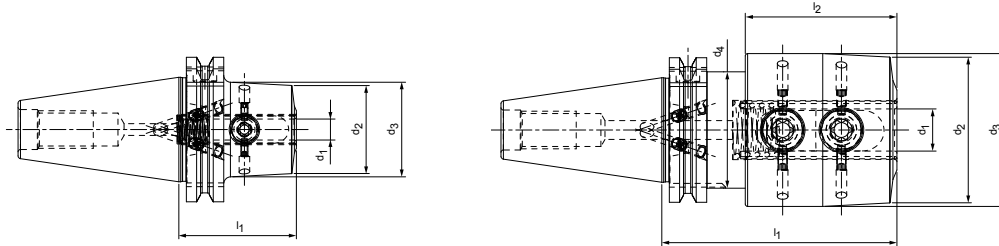

Preferred series available from stock

Steep taper	Dimensions						Order designation	Order no.
	d ₁	d ₂	d ₃	d ₄	l ₁	l ₂		
40	6,0	22,5	25,4	-	50,0	-	15.256.40.06.Z/50	31090489
40	8,0	25,0	27,9	-	50,0	-	15.256.40.08.Z/50	31090490
40	10,0	32,0	34,8	-	50,0	-	15.256.40.10.Z/50	31090491
40	12,0	37,5	40,3	-	50,0	-	15.256.40.12.Z/50	31090492
40	16,0	43,0	47,3	-	63,0	-	15.256.40.16.Z/63	31090494
40	20,0	46,5	46,5	-	63,0	-	15.256.40.20.Z/63	31090496
40	25,0	62,0	65,0	49,5	100,0	64,5	15.256.40.25.Z/100	31090497
40	32,0	69,0	72,0	49,5	100,0	64,5	15.256.40.32.Z/100	31090498
50	6,0	22,5	26,7	-	63,0	-	15.256.50.06.Z/63	31090499
50	8,0	25,0	29,2	-	63,0	-	15.256.50.08.Z/63	31090500
50	10,0	32,0	36,2	-	63,0	-	15.256.50.10.Z/63	31090501
50	12,0	37,5	41,7	-	63,0	-	15.256.50.12.Z/63	31090502
50	16,0	43,0	47,1	-	63,0	-	15.256.50.16.Z/63	31090504
50	20,0	46,5	50,6	-	63,0	-	15.256.50.20.Z/63	31090506
50	25,0	62,0	67,8	-	80,0	-	15.256.50.25.Z/80	31090507
50	32,0	69,0	76,0	-	100,0	-	15.256.50.32.Z/100	31090508

Dimensions in mm.

For accessories and spare parts see "Accessories and spare parts" section.

Additional dimensions and special designs available upon request.

CNC precision drill chucks

Without coolant outlet

HSK-A (hollow shank taper form A) shank according to DIN 69893-1

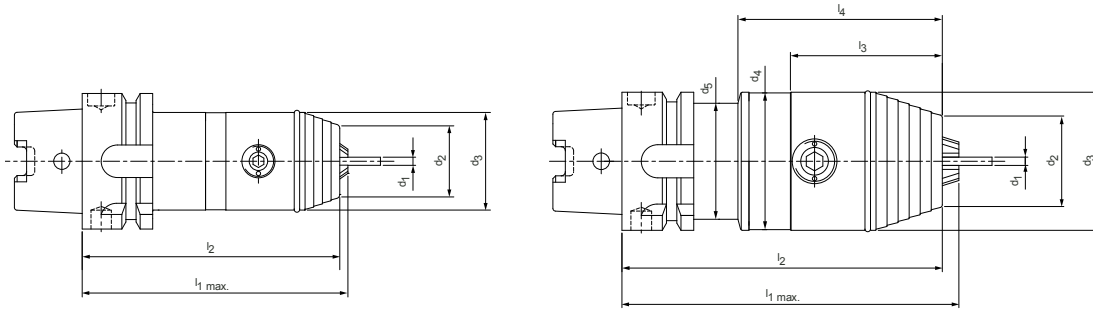

Preferred series available from stock

HSK-A	Dimensions									Order designation	Order no.
	Clamping range d ₁	d ₂	d ₃	d ₄	d ₅	l _{1 max.}	l ₂	l ₃	l ₄		
32	0,3 - 8,0	23,0	36,0	-	-	93,0	90,0	-	-	16.296.32.08	30335995
40	0,3 - 8,0	23,0	36,0	-	-	94,0	91,0	-	-	16.296.40.08	30335998
50	0,3 - 8,0	23,0	36,0	-	-	98,0	95,0	-	-	16.296.50.08	30336001
50	0,5 - 13,0	35,0	50,0	49,5	41,5	122,0	116,0	55,0	74,0	16.296.50.13	30336004
50	2,5 - 16,0	36,0	57,0	50,0	41,5	127,0	121,0	56,5	78,0	16.296.50.16	30336007
63	0,3 - 8,0	23,0	36,0	-	-	99,0	96,0	-	-	16.296.63.08	30336010
63	0,5 - 13,0	35,0	50,0	-	-	110,0	104,0	-	-	16.296.63.13	30336013
63	2,5 - 16,0	36,0	57,0	50,0	-	115,0	109,0	56,5	-	16.296.63.16	30336017
100	0,5 - 13,0	35,0	50,0	-	-	117,0	111,0	-	-	16.296.100.13	30335988
100	2,5 - 16,0	36,0	57,0	50,0	-	122,0	116,0	56,5	-	16.296.100.16	30335992

Available on request

80	0,5 - 13,0	35,0	50,0	-	-	115,0	109,0	-	-	16.296.80.13	30336021
80	2,5 - 16,0	36,0	57,0	-	-	120,0	114,0	-	-	16.296.80.16	30336024

Dimensions in mm.

For accessories and spare parts see "Accessories and spare parts" section.

Additional dimensions and special designs available upon request.

CNC precision drill chucks

With centralised coolant outlet

HSK-A (hollow shank taper form A) shank according to DIN 69893-1

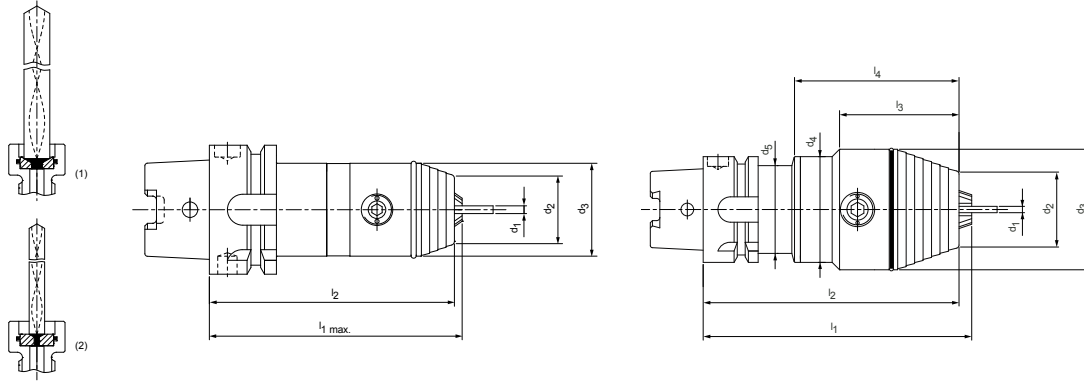

Preferred series available from stock

HSK-A	Dimensions										Order designation	Order no.
	Clamping range d ₁	d ₂	d ₃	d ₄	d ₅	l _{1 max.}	l ₂	l ₃	l ₄			
32	0,3 - 8,0	23,0	36,0	-	-	93,0	90,0	-	-	16.296.32.08.Z	30335996	
40	0,3 - 8,0	23,0	36,0	-	-	94,0	91,0	-	-	16.296.40.08.Z	30335999	
50	0,3 - 8,0	23,0	36,0	-	-	98,0	95,0	-	-	16.296.50.08.Z	30336002	
50	0,5 - 13,0	35,0	50,0	49,8	41,5	122,0	116,0	55,0	74,0	16.296.50.13.Z	30336005	
50	2,5 - 16,0	36,0	57,0	49,8	41,5	127,0	121,0	56,5	78,0	16.296.50.16.Z	30336008	
63	0,3 - 8,0	23,0	36,0	-	-	99,0	96,0	-	-	16.296.63.08.Z	30336011	
63	0,5 - 13,0	35,0	50,0	-	-	110,0	104,0	-	-	16.296.63.13.Z	30336014	
63	2,5 - 16,0	36,0	57,0	49,8	-	115,0	109,0	56,5	-	16.296.63.16.Z	30336018	
100	0,5 - 13,0	35,0	50,0	-	-	117,0	111,0	-	-	16.296.100.13.Z	30335989	
100	2,5 - 16,0	36,0	57,0	49,8	-	122,0	116,0	56,5	-	16.296.100.16.Z	30335993	

Available on request

80	0,5 - 13,0	35,0	50,0	-	-	115,0	109,0	-	-	16.296.80.13.Z	30336022
80	2,5 - 16,0	36,0	57,0	-	-	120,0	114,0	-	-	16.296.80.16.Z	30336025

(1) Sealing disc WTE 08 (ø 3.2 mm) installed in drill chuck head, for cooling channel drills ø 4-8 mm with straight shank according to DIN 6535, Form HA.

(2) Sealing disc WTE 08 (ø 1.8mm) included in scope of delivery, for cooling channel drills ø 2-4 mm with straight shank according to DIN 6535, Form HA.

(1) Sealing disc WTE 13 (ø 4.2 mm) installed in drill chuck head, for cooling channel drills ø 6-13 mm with straight shank according to DIN 6535, Form HA.

(2) Sealing disc WTE 13 (ø 2.05mm) included in scope of delivery, for cooling channel drills ø 3-6 mm with straight shank according to DIN 6535, Form HA.

(1) Sealing disc WTE 16 (ø 4.2 mm) installed in drill chuck head, for cooling channel drills ø 6-16 mm with straight shank according to DIN 6535, Form HA.

(2) Sealing disc WTE 16 (ø 2.05mm) included in scope of delivery, for cooling channel drills ø 3-6 mm with straight shank according to DIN 6535, Form HA.

Dimensions in mm.

For accessories and spare parts see "Accessories and spare parts" section.

Additional dimensions and special designs available upon request.

CNC precision drill chucks

With decentralised coolant outlet

HSK-A (hollow shank taper form A) shank according to DIN 69893-1

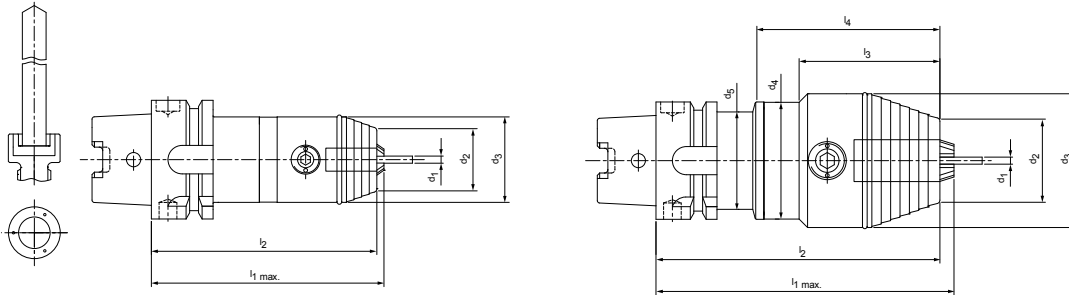

Preferred series available from stock

HSK-A	Dimensions									Order designation	Order no.
	Clamping range d ₁	d ₂	d ₃	d ₄	d ₅	l _{1 max.}	l ₂	l ₃	l ₄		
32	0,3 - 8,0	23,0	36,0	-	-	93,0	90,0	-	-	16.296.32.08.ZBA	30335997
40	0,3 - 8,0	23,0	36,0	-	-	94,0	91,0	-	-	16.296.40.08.ZBA	30336000
50	0,3 - 8,0	23,0	36,0	-	-	98,0	95,0	-	-	16.296.50.08.ZBA	30336003
50	0,5 - 13,0	35,0	50,0	49,8	41,5	122,0	116,0	60,0	78,0	16.296.50.13.ZBA	30336006
50	2,5 - 16,0	36,0	57,0	49,8	41,5	127,0	121,0	56,5	78,0	16.296.50.16.ZBA	30336009
63	0,3 - 8,0	23,0	36,0	-	-	99,0	96,0	-	-	16.296.63.08.ZBA	30336012
63	0,5 - 13,0	35,0	50,0	-	-	110,0	104,0	-	-	16.296.63.13.ZBA	30336016
63	2,5 - 16,0	36,0	57,0	49,8	-	115,0	109,0	60,0	-	16.296.63.16.ZBA	30336020
100	0,5 - 13,0	35,0	50,0	-	-	117,0	111,0	-	-	16.296.100.13.ZBA	30335990
100	2,5 - 16,0	36,0	57,0	49,8	-	122,0	116,0	60,0	-	16.296.100.16.ZBA	30335994

Available on request

80	0,5 - 13,0	35,0	50,0	-	-	115,0	109,0	-	-	16.296.80.13.ZBA	30336023
80	2,5 - 16,0	36,0	57,0	-	-	120,0	114,0	-	-	16.296.80.16.ZBA	30336026

Dimensions in mm.

For accessories and spare parts see "Accessories and spare parts" section.

Additional dimensions and special designs available upon request.

CNC precision drill chucks

Without coolant outlet

Shank SK according to ISO 7388-1 Form AD

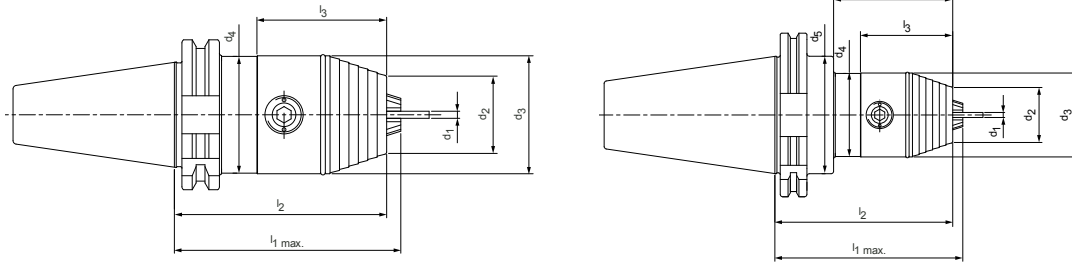

Preferred series available from stock

Steep taper	Dimensions									Order designation	Order no.
	Clamping range d ₁	d ₂	d ₃	d ₄	d ₅	l ₁ max.	l ₂	l ₃	l ₄		
30	0,3 - 8,0	23,0	36,0	-	-	73,0	70,0	40,5	-	11.296.30.08	30335949
30	0,5 - 13,0	35,0	50,0	49,8	45,0	117,0	111,0	54,5	76,0	11.296.30.13	30335950
40	0,3 - 8,0	23,0	36,0	-	-	73,0	70,0	40,5	-	11.296.40.08	30335952
40	0,5 - 13,0	35,0	50,0	-	-	96,0	90,0	54,5	-	11.296.40.13	30335953
40	2,5 - 16,0	36,0	57,0	49,8	-	101,0	95,0	60,0	-	11.296.40.16	30335954
50	0,5 - 13,0	35,0	50,0	49,8	70,0	112,0	106,0	54,5	76,0	11.296.50.13	30335959
50	2,5 - 16,0	36,0	57,0	49,8	-	117,0	111,0	60,0	76,0	11.296.50.16	30335962

Dimensions in mm.

For accessories and spare parts see "Accessories and spare parts" section.

Additional dimensions and special designs available upon request.

CNC precision drill chucks

With centralised coolant outlet

Shank SK in accordance with ISO 7388-1 Form AD/ AF

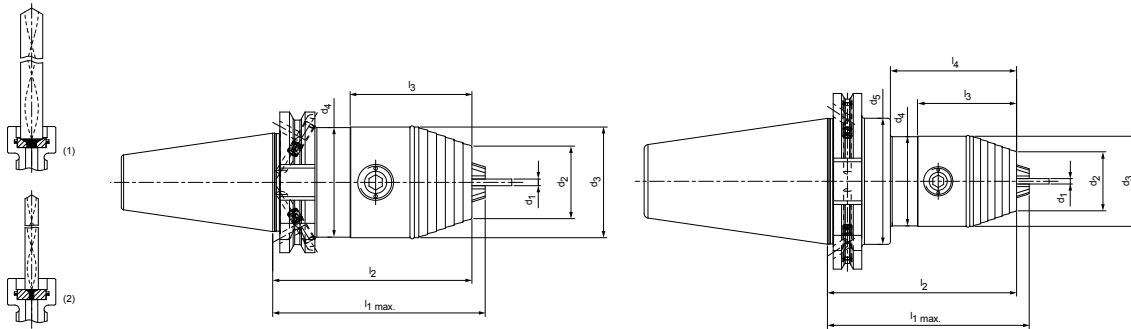

Preferred series available from stock

Steep taper	Dimensions									Order designation	Order no.
	Clamping range d_1	d_2	d_3	d_4	d_5	$l_1 \text{ max.}$	l_2	l_3	l_5		
40	0,3 - 8,0	23,0	36,0	-	-	76,0	73,0	-	-	15.296.40.08	30335971
40	0,5 - 13,0	35,0	50,0	-	-	96,0	90,0	-	-	15.296.40.13	30335973
40	2,5 - 16,0	36,0	57,0	49,8	-	101,0	95,0	60,0	-	15.296.40.16	30335976
50	0,5 - 13,0	35,0	50,0	49,8	70,0	112,0	105,0	54,5	71,0	15.296.50.13	30335984
50	2,5 - 16,0	36,0	57,0	49,8	70,0	117,0	111,0	60,0	76,0	15.296.50.16	30335986

(1) Sealing disc WTE 08 (\varnothing 3.2 mm) installed in drill chuck head, for cooling channel drills \varnothing 4-8 mm with straight shank according to DIN 6535, Form HA.

(2) Sealing disc WTE 08 (\varnothing 1.8mm) included in scope of delivery, for cooling channel drills \varnothing 2-4 mm with straight shank according to DIN 6535, Form HA.

(1) Sealing disc WTE 13 (\varnothing 4.2 mm) installed in drill chuck head, for cooling channel drills \varnothing 6-13 mm with straight shank according to DIN 6535, Form HA.

(2) Sealing disc WTE 13 (\varnothing 2.05mm) included in scope of delivery, for cooling channel drills \varnothing 3-6 mm with straight shank according to DIN 6535, Form HA.

(1) Sealing disc WTE 16 (\varnothing 4.2 mm) installed in drill chuck head, for cooling channel drills \varnothing 6-16 mm with straight shank according to DIN 6535, Form HA.

(2) Sealing disc WTE 16 (\varnothing 2.05mm) included in scope of delivery, for cooling channel drills \varnothing 3-6 mm with straight shank according to DIN 6535, Form HA.

Dimensions in mm.

For accessories and spare parts see "Accessories and spare parts" section.

Additional dimensions and special designs available upon request.

CNC precision drill chucks

With decentralised coolant outlet

Shank SK in accordance with ISO 7388-1 Form AD/ AF

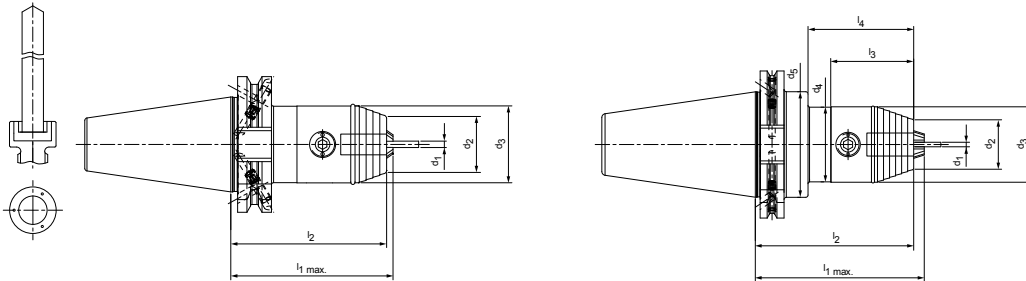

Preferred series available from stock

Steep taper	Dimensions									Order designation	Order no.
	Clamping range d_1	d_2	d_3	d_4	d_5	l_1 max.	l_2	l_3	l_4		
40	0,3 - 8,0	23,0	36,0	-	-	76,0	73,0	-	-	15.296.40.08.ZBA	30335972
40	0,5 - 13,0	35,0	50,0	-	-	96,0	90,0	-	-	15.296.40.13.ZBA	30335974
40	2,5 - 16,0	36,0	57,0	49,8	-	101,0	95,0	60,0	-	15.296.40.16.ZBA	30335977
50	0,5 - 13,0	35,0	50,0	49,8	70,0	112,0	105,0	54,5	71,0	15.296.50.13.ZBA	30335985
50	2,5 - 16,0	36,0	57,0	49,8	70,0	117,0	111,0	60,0	76,0	15.296.50.16.ZBA	30335987

Dimensions in mm.

For accessories and spare parts see "Accessories and spare parts" section.
Additional dimensions and special designs available upon request.

CNC precision drill chucks

Without coolant outlet

Shank BT according to ISO 7388-2 Form JD / JF (JIS B 6339)

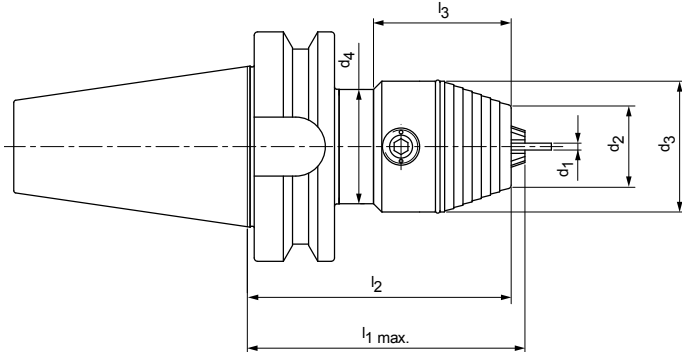

Preferred series available from stock

BT	Dimensions							Order designation	Order no.
	Clamping range d_1	d_2	d_3	d_4	$l_1 \text{ max.}$	l_2	l_3		
40	0,3 - 8,0	23,0	36,0	35,8	81,0	78,0	40,5	20.296.40.08	30336055
40	0,5 - 13,0	35,0	50,0	49,8	104,0	98,0	54,5	20.296.40.13	30336056
40	2,5 - 16,0	36,0	57,0	49,8	109,0	103,0	60,0	20.296.40.16	30336057
50	0,5 - 13,0	35,0	50,0	49,8	116,0	110,0	54,5	20.296.50.13	30336060
50	2,5 - 16,0	36,0	57,0	49,8	121,0	115,0	60,0	20.296.50.16	30336061

Dimensions in mm.

For accessories and spare parts see "Accessories and spare parts" section.

Additional dimensions and special designs available upon request.

CNC precision drill chucks

With centralised coolant outlet

Shank BT according to ISO 7388-2 Form JD / JF (JIS B 6339)

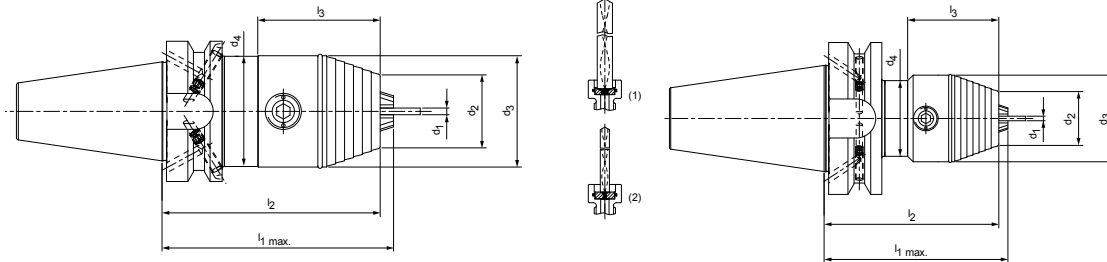

Preferred series available from stock

BT	Dimensions							Order designation	Order no.
	Clamping range d_1	d_2	d_3	d_4	l_1 max.	l_2	l_3		
40	0,3 - 8,0	23,0	36,0	-	84,0	81,0	-	22.296.40.08	30336062
40	0,5 - 13,0	35,0	50,0	-	104,0	98,0	-	22.296.40.13	30336064
40	2,5 - 16,0	36,0	57,0	49,8	109,0	103,0	60,0	22.296.40.16	30336067
50	0,5 - 13,0	35,0	50,0	49,8	116,0	110,0	54,5	22.296.50.13	30336070
50	2,5 - 16,0	36,0	57,0	49,8	121,0	115,0	60,0	22.296.50.16	30336072

(1) Sealing disc WTE 08 (\varnothing 3.2 mm) installed in drill chuck head, for cooling channel drills \varnothing 4-8 mm with straight shank according to DIN 6535, Form HA.

(2) Sealing disc WTE 08 (\varnothing 1.8mm) included in scope of delivery, for cooling channel drills \varnothing 2-4 mm with straight shank according to DIN 6535, Form HA.

(1) Sealing disc WTE 13 (\varnothing 4.2 mm) installed in drill chuck head, for cooling channel drills \varnothing 6-13 mm with straight shank according to DIN 6535, Form HA.

(2) Sealing disc WTE 13 (\varnothing 2.05mm) included in scope of delivery, for cooling channel drills \varnothing 3-6 mm with straight shank according to DIN 6535, Form HA.

(1) Sealing disc WTE 16 (\varnothing 4.2 mm) installed in drill chuck head, for cooling channel drills \varnothing 6-16 mm with straight shank according to DIN 6535, Form HA.

(2) Sealing disc WTE 16 (\varnothing 2.05mm) included in scope of delivery, for cooling channel drills \varnothing 3-6 mm with straight shank according to DIN 6535, Form HA.

Dimensions in mm.

For accessories and spare parts see "Accessories and spare parts" section.

Additional dimensions and special designs available upon request.

CNC precision drill chucks

With decentralised coolant outlet for tools without IK
Shank BT according to ISO 7388-2 Form JD / JF (JIS B 6339)

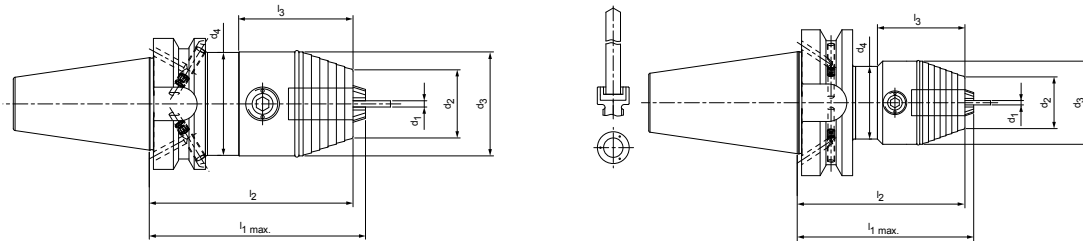

Preferred series available from stock

BT	Dimensions							Order designation	Order no.
	Clamping range d_1	d_2	d_3	d_4	l_1 max.	l_2	l_3		
40	0,3 - 8,0	23,0	36,0	-	84,0	81,0	-	22.296.40.08.ZBA	30336063
40	0,5 - 13,0	35,0	50,0	-	104,0	98,0	-	22.296.40.13.ZBA	30336065
40	2,5 - 16,0	36,0	57,0	49,8	109,0	103,0	60,0	22.296.40.16.ZBA	30336068
50	0,5 - 13,0	35,0	50,0	49,8	116,0	110,0	54,5	22.296.50.13.ZBA	30336071
50	2,5 - 16,0	36,0	57,0	49,8	121,0	115,0	60,0	22.296.50.16.ZBA	30336073

Dimensions in mm.

For accessories and spare parts see "Accessories and spare parts" section.
Additional dimensions and special designs available upon request.

CNC precision drill chucks

Without coolant outlet

Shank SK according to DIN 2080 Form A

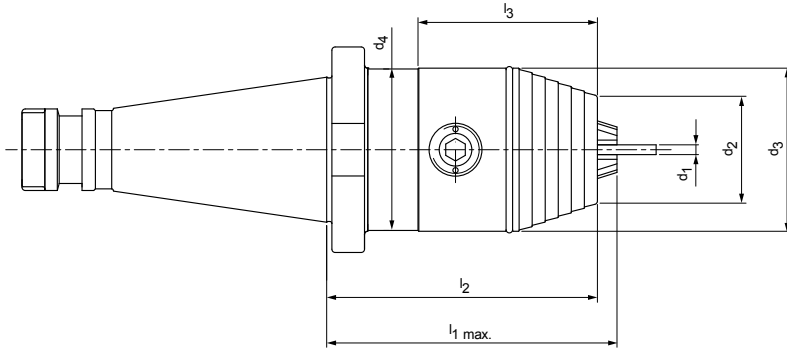

Available on request

SK/ISO	Dimensions							Order designation	Order no.
	Clamping range d_1	d_2	d_3	d_4	$l_1 \text{ max.}$	l_2	l_3		
30	0,3 - 8,0	23,0	36,0	35,8	63,0	60,0	42,0	10.296.30.08	30335939
40	0,3 - 8,0	23,0	36,0	35,8	65,0	62,0	42,0	10.296.40.08	30335942
30	0,5 - 13,0	35,0	50,0	49,8	104,0	98,0	55,0	10.296.30.13	30335940
40	0,5 - 13,0	35,0	50,0	49,5	89,0	83,0	55,0	10.296.40.13	30335944
50	0,5 - 13,0	35,0	50,0	49,5	106,0	100,0	55,0	10.296.50.13	30335947
40	2,5 - 16,0	36,0	57,0	50,0	94,0	88,0	60,0	10.296.40.16	30335945
50	2,5 - 16,0	36,0	57,0	50,0	111,0	105,0	60,0	10.296.50.16	30335948

Dimensions in mm.

For accessories and spare parts see "Accessories and spare parts" section.

Additional dimensions and special designs available upon request.

CNC precision drill chucks

Without coolant outlet

Shank WTE PLUS according to DIN 238

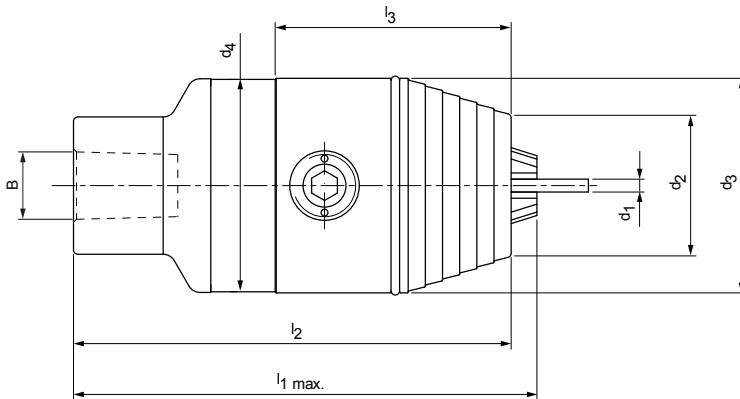

Available on request

B	Dimensions							Order designation	Order no.
	Clamping range d_1	d_2	d_3	d_4	l_1 max.	l_2	l_3		
B 12	0,3 - 8,0	23,0	36,0	35,8	79,0	76,0	42,0	12.296.B12.08	30344488
B 12	0,5 - 13,0	35,0	50,0	49,8	104,0	98,0	55,0	12.296.B12.13	30344489
B 16	0,3 - 8,0	23,0	36,0	35,8	85,0	82,0	42,0	12.296.B16.08	30344490
B 16	0,5 - 13,0	35,0	50,0	49,8	108,0	102,0	55,0	12.296.B16.13	30344491
B 16	2,5 - 16,0	36,0	57,0	49,8	113,0	107,0	60,0	12.296.B16.16	30344492
B 18	0,5 - 13,0	35,0	50,0	49,8	116,0	110,0	55,0	12.296.B18.13	30344493
B 18	2,5 - 16,0	36,0	57,0	49,8	121,0	115,0	60,0	12.296.B18.16	30344494

Dimensions in mm.

For accessories and spare parts see "Accessories and spare parts" section.

Additional dimensions and special designs available upon request.

CNC precision drill chucks

Without coolant outlet

Shank HSK-F according to DIN 69893-6

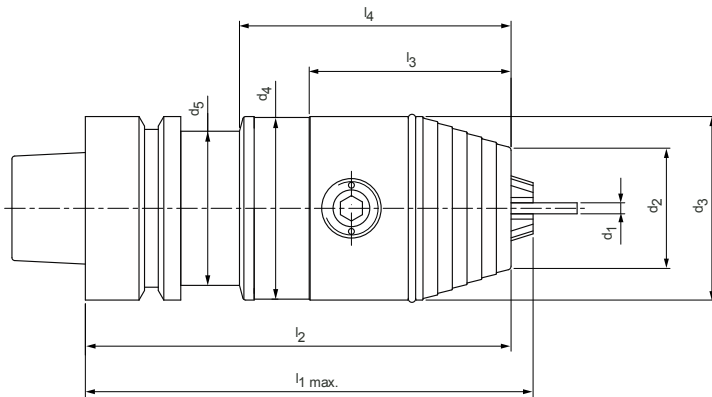

Available on request

HSK-F	Dimensions									Order designation	Order no.
	Clamping range d_1	d_2	d_3	d_4	d_5	$l_1 \text{ max.}$	l_2	l_3	l_4		
40	0,3 - 8,0	23,0	36,0	35,8	-	90,0	87,0	42,0	49,5	17.296.40.08	30336027
50	0,5 - 13,0	35,0	50,0	49,5	41,5	122,0	116,0	55,0	75,0	17.296.50.13	30336028
63	0,5 - 13,0	35,0	50,0	49,8	-	103,0	97,0	55,0	-	17.296.63.13	30336031
50	2,5 - 16,0	36,0	57,0	49,8	41,5	127,0	121,0	60,0	75,0	17.296.50.16	30336029
63	2,5 - 16,0	36,0	57,0	49,8	-	108,0	102,0	60,0	75,0	17.296.63.16	30336032

Dimensions in mm.

For accessories and spare parts see "Accessories and spare parts" section.

Additional dimensions and special designs available upon request.

CNC precision drill chucks

Without coolant outlet

Shank hollow shank taper E according to DIN 69893-5

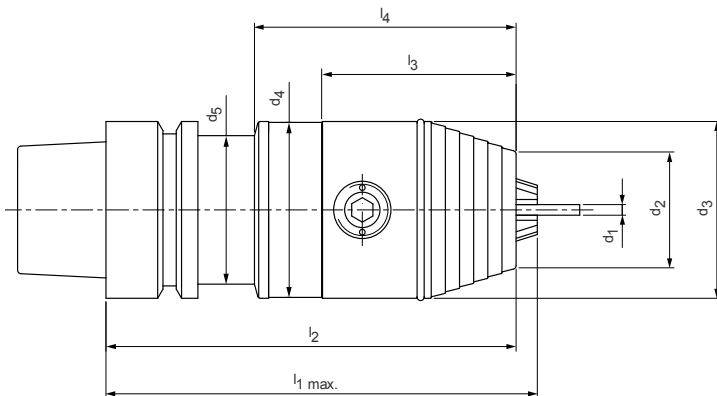

Available on request

HSK-E	Dimensions									Order designation	Order no.
	Clamping range d ₁	d ₂	d ₃	d ₄	d ₅	l ₁ max.	l ₂	l ₃	l ₄		
40	0,3 - 8,0	23,0	36,0	-	-	94,0	91,0	-	-	18.296.40.08	30336033
50	0,3 - 8,0	23,0	36,0	-	-	98,0	95,0	-	-	18.296.50.08	30336035
63	0,3 - 8,0	23,0	36,0	-	-	99,0	96,0	-	-	18.296.63.08	30336043
50	0,5 - 13,0	35,0	50,0	49,8	41,5	122,0	116,0	55,0	70,0	18.296.50.13	30336038
63	0,5 - 13,0	35,0	50,0	49,8	50,0	110,0	104,0	55,0	70,0	18.296.63.13	30336045
50	2,5 - 16,0	36,0	57,0	49,8	41,5	127,0	121,0	60,0	75,0	18.296.50.16	30336041
63	2,5 - 16,0	36,0	57,0	49,8	50,0	115,0	109,0	60,0	75,0	18.296.63.16	30336047

Dimensions in mm.

For accessories and spare parts see "Accessories and spare parts" section.

Additional dimensions and special designs available upon request.

CNC precision drill chucks

With centralised coolant outlet

Shank hollow shank taper E according to DIN 69893-5

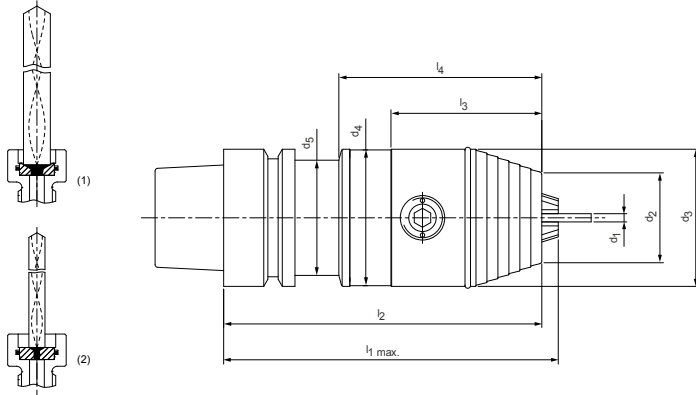

Available on request

HSK-E	Dimensions									Order designation	Order no.
	Clamping range d_1	d_2	d_3	d_4	d_5	$l_1 \text{ max.}$	l_2	l_3	l_4		
40	0,3 - 8,0	23,0	36,0	-	-	94,0	91,0	-	-	18.296.40.08.Z	30336034
50	0,3 - 8,0	23,0	36,0	-	-	98,0	95,0	-	-	18.296.50.08.Z	30336036
63	0,3 - 8,0	23,0	36,0	-	-	99,0	96,0	-	-	18.296.63.08.Z	30336044
50	0,5 - 13,0	35,0	50,0	49,8	41,5	122,0	116,0	55,0	70,0	18.296.50.13.Z	30336039
63	0,5 - 13,0	35,0	50,0	49,8	50,0	110,0	104,0	55,0	70,0	18.296.63.13.Z	30336046
50	2,5 - 16,0	36,0	57,0	49,8	41,5	127,0	121,0	60,0	75,0	18.296.50.16.Z	30336042
63	2,5 - 16,0	36,0	57,0	49,8	50,0	115,0	109,0	60,0	75,0	18.296.63.16.Z	30336048

(1) Sealing disc WTE 08 (\varnothing 3.2 mm) installed in drill chuck head, for cooling channel drills \varnothing 4-8 mm with straight shank according to DIN 6535, Form HA.

(2) Sealing disc WTE 08 (\varnothing 1.8mm) included in scope of delivery, for cooling channel drills \varnothing 2-4 mm with straight shank according to DIN 6535, Form HA.

(1) Sealing disc WTE 13 (\varnothing 4.2 mm) installed in drill chuck head, for cooling channel drills \varnothing 6-13 mm with straight shank according to DIN 6535, Form HA.

(2) Sealing disc WTE 13 (\varnothing 2.05mm) included in scope of delivery, for cooling channel drills \varnothing 3-6 mm with straight shank according to DIN 6535, Form HA.

(1) Sealing disc WTE 16 (\varnothing 4.2 mm) installed in drill chuck head, for cooling channel drills \varnothing 6-16 mm with straight shank according to DIN 6535, Form HA.

(2) Sealing disc WTE 16 (\varnothing 2.05mm) included in scope of delivery, for cooling channel drills \varnothing 3-6 mm with straight shank according to DIN 6535, Form HA.

Dimensions in mm.

For accessories and spare parts see "Accessories and spare parts" section.

Additional dimensions and special designs available upon request.

CNC precision drill chucks

Without coolant outlet

Shank morse taper according to DIN 228-A (without tang)

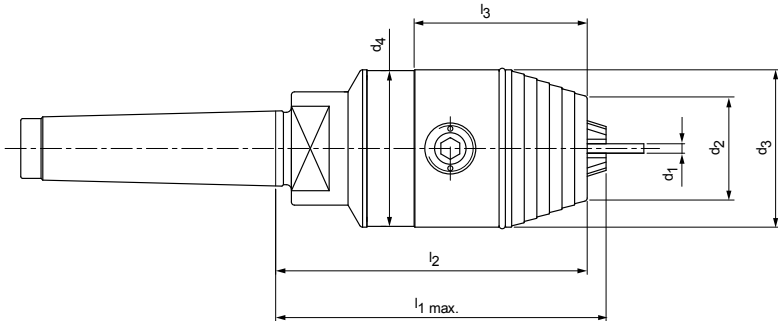

Available on request

MK	Dimensions							Order designation	Order no.
	Clamping range d_1	d_2	d_3	d_4	$l_1 \text{ max.}$	l_2	l_3		
MK2	0,3 - 8,0	23,0	36,0	35,8	76,0	73,0	42,0	36.296.02.08	30336113
MK3	0,3 - 8,0	23,0	36,0	35,8	76,0	73,0	42,0	36.296.03.08	30336115
MK2	0,5 - 13,0	35,0	50,0	49,8	105,0	99,0	55,0	36.296.02.13	30336114
MK3	0,5 - 13,0	35,0	50,0	49,8	105,0	99,0	55,0	36.296.03.13	30336116
MK4	0,5 - 13,0	35,0	50,0	49,8	110,0	104,0	55,0	36.296.04.13	30336118
MK5	0,5 - 13,0	35,0	50,0	49,8	112,0	106,0	55,0	36.296.05.13	30336120
MK3	2,5 - 16,0	36,0	57,0	49,8	110,0	104,0	60,0	36.296.03.16	30336117
MK4	2,5 - 16,0	36,0	57,0	49,8	115,0	109,0	60,0	36.296.04.16	30336119
MK5	2,5 - 16,0	36,0	57,0	49,8	117,0	111,0	60,0	36.296.05.16	30336121

Dimensions in mm.

For accessories and spare parts see "Accessories and spare parts" section.

Additional dimensions and special designs available upon request.

CNC precision drill chucks

Without coolant outlet

Shank morse taper according to DIN 228-B (with tang)

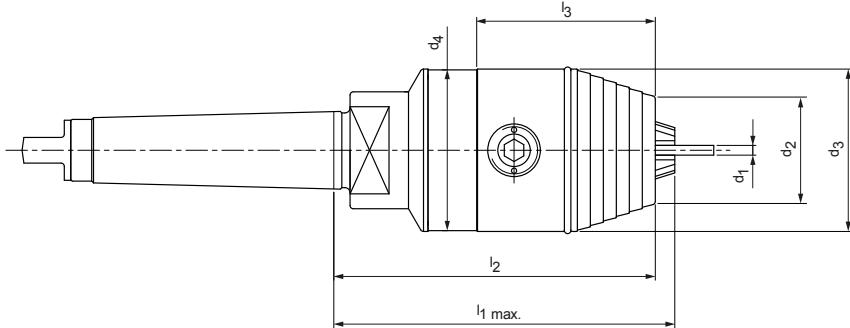

Available on request

MK	Dimensions							Order designation	Order no.
	Clamping range d_1	d_2	d_3	d_4	$l_1 \text{ max.}$	l_2	l_3		
MK2	0,3 - 8,0	23,0	36,0	35,8	76,0	73,0	42,0	37.296.02.08	30336122
MK3	0,3 - 8,0	23,0	36,0	35,8	76,0	73,0	42,0	37.296.03.08	30336125
MK2	0,5 - 13,0	35,0	50,0	49,8	105,0	99,0	55,0	37.296.02.13	30336123
MK3	0,5 - 13,0	35,0	50,0	49,8	105,0	99,0	55,0	37.296.03.13	30336126
MK4	0,5 - 13,0	35,0	50,0	49,8	110,0	104,0	55,0	37.296.04.13	30336128
MK5	0,5 - 13,0	35,0	50,0	49,8	112,0	106,0	55,0	37.296.05.13	30336130
MK3	2,5 - 16,0	36,0	57,0	49,8	110,0	104,0	60,0	37.296.03.16	30336127
MK4	2,5 - 16,0	36,0	57,0	49,8	115,0	109,0	60,0	37.296.04.16	30336129
MK5	2,5 - 16,0	36,0	57,0	49,8	117,0	111,0	60,0	37.296.05.16	30336131

Dimensions in mm.

For accessories and spare parts see "Accessories and spare parts" section.

Additional dimensions and special designs available upon request.

CNC precision drill chucks

With lateral coolant supply through quick coupling
Shank morse taper according to DIN 228-B (with tang)

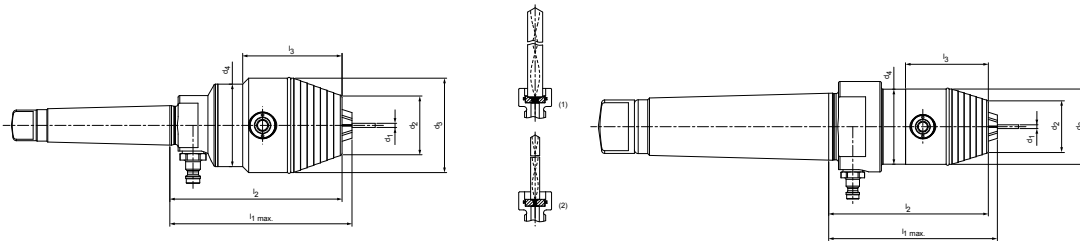

Available on request

MK	Dimensions							Order designation	Order no.
	Clamping range d_1	d_2	d_3	d_4	$l_1 \text{ max.}$	l_2	l_3		
MK3	0,5 - 13,0	35,0	50,0	49,8	105,0	99,0	55,0	37.296.03.13.Z	30888211
MK4	0,5 - 13,0	35,0	50,0	49,8	110,0	104,0	55,0	37.296.04.13.Z	30888215
MK5	0,5 - 13,0	35,0	50,0	49,8	112,0	106,0	55,0	37.296.05.13.Z	30888218
MK3	2,5 - 16,0	36,0	57,0	49,8	110,0	104,0	60,0	37.296.03.16.Z	30888222
MK4	2,5 - 16,0	36,0	57,0	49,8	115,0	109,0	60,0	37.296.04.16.Z	30888226
MK5	2,5 - 16,0	36,0	57,0	49,8	117,0	111,0	60,0	37.296.05.16.Z	30888229

Hose connection of the quick coupling Sd	Order designation	Order no.
Ø4	89.220.82	30889099
Ø6	89.220.83	30889101
Ø8	89.220.84	30889103
Ø10	89.220.85	30889104

	Order designation	Order no.
(1) Sealing disc (Ø 1.5 mm) installed in drill chuck head, for cooling channel drills Ø 2-6 mm with straight shank according to DIN 6535, Form HA.	89.213.76	30916451
(2) Sealing disc (Ø 5 mm) available upon request, for cooling channel drills Ø 6-13 mm with straight shank according to DIN 6535, Form HA.	89.213.77	30916452
(1) Sealing disc (Ø 2 mm) installed in drill chuck head, for cooling channel drills Ø 2.5-8 mm with straight shank according to DIN 6535, Form HA.	89.216.81	30916454
(2) Sealing disc (Ø 7.5 mm) available upon request, for cooling channel drills Ø 8-16 mm with straight shank according to DIN 6535, Form HA.	89.216.82	30916459

Dimensions in mm.

For accessories and spare parts see "Accessories and spare parts" section.
Additional dimensions and special designs available upon request.

CNC precision drill chucks

Without coolant outlet

Cylindrical shank according to DIN 1835-B

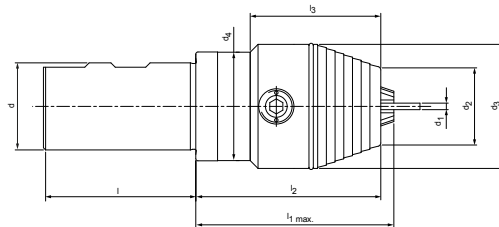
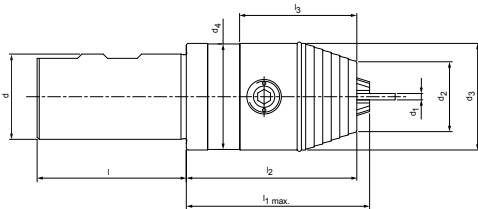

Available on request

DIN 1835-B	Dimensions							Order designation	Order no.
	Clamping range d_1	d_2	d_3	d_4	$l_1 \text{ max.}$	l_2	l_3		
20x50	0,3 - 8,0	23,0	36,0	35,8	62,0	59,0	42,0	40.296.20.08	30336132
25x56	0,3 - 8,0	23,0	36,0	35,8	55,0	52,0	42,0	40.296.25.08	30336135
32x60	0,3 - 8,0	23,0	36,0	35,8	55,0	52,0	42,0	40.296.32.08	30336038
20x50	0,5 - 13,0	35,0	50,0	49,8	88,0	82,0	55,0	40.296.20.13	30336133
25x56	0,5 - 13,0	35,0	50,0	49,8	88,0	82,0	55,0	40.296.25.13	30336136
32x60	0,5 - 13,0	35,0	50,0	49,8	88,0	82,0	55,0	40.296.32.13	30336139
40x70	0,5 - 13,0	35,0	50,0	49,8	86,0	80,0	55,0	40.296.40.13	30336141
50x80	0,5 - 13,0	35,0	50,0	49,8	86,0	80,0	55,0	40.296.50.13	30336143
25x56	2,5 - 16,0	36,0	57,0	49,8	93,0	87,0	60,0	40.296.25.16	30336137
32x60	2,5 - 16,0	36,0	57,0	49,8	93,0	87,0	60,0	40.296.32.16	30336140
40x70	2,5 - 16,0	36,0	57,0	49,8	91,0	85,0	60,0	40.296.40.16	30336142
50x80	2,5 - 16,0	36,0	57,0	49,8	91,0	85,0	60,0	40.296.50.16	30336144

Dimensions in mm.

For accessories and spare parts see "Accessories and spare parts" section.

Additional dimensions and special designs available upon request.

CNC precision drill chucks

With centralised coolant outlet

Cylindrical shank according to DIN 1835-B

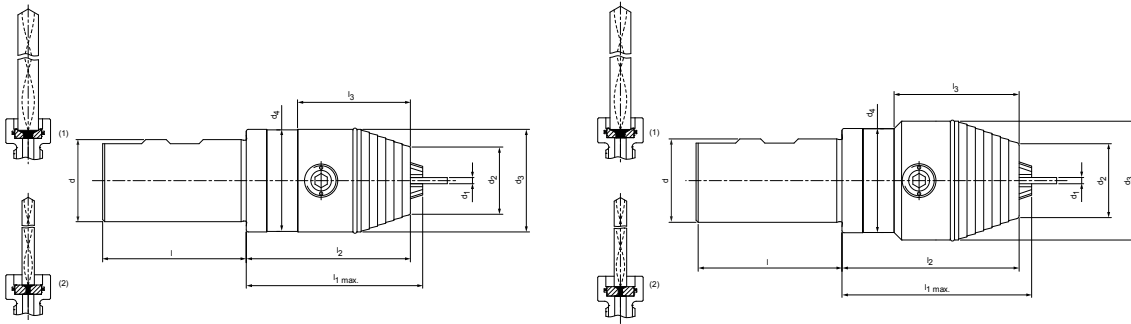

Available on request

DIN 1835-B	Dimensions							Order designation	Order no.
	Clamping range d_1	d_2	d_3	d_4	$l_1 \text{ max.}$	l_2	l_3		
20x50	0,3 - 8,0	23,0	36,0	35,8	62,0	59,0	42,0	41.296.20.08.Z	30336145
25x56	0,3 - 8,0	23,0	36,0	35,8	55,0	52,0	42,0	41.296.25.08.Z	30336148
32x60	0,3 - 8,0	23,0	36,0	35,8	55,0	52,0	42,0	41.296.32.08.Z	30336154
20x50	0,5 - 13,0	35,0	50,0	49,8	88,0	82,0	55,0	41.296.20.13.Z	30336146
25x56	0,5 - 13,0	35,0	50,0	49,8	88,0	82,0	55,0	41.296.25.13.Z	30336150
32x60	0,5 - 13,0	35,0	50,0	49,8	88,0	82,0	55,0	41.296.32.13.Z	30336155
40x70	0,5 - 13,0	35,0	50,0	49,8	86,0	80,0	55,0	41.296.40.13.Z	30336158
50x80	0,5 - 13,0	35,0	50,0	49,8	86,0	80,0	55,0	41.296.50.13.Z	30336162
25x56	2,5 - 16,0	36,0	57,0	49,8	93,0	87,0	60,0	41.296.25.16.Z	30336152
32x60	2,5 - 16,0	36,0	57,0	49,8	93,0	87,0	60,0	41.296.32.16.Z	30336157
40x70	2,5 - 16,0	36,0	57,0	49,8	91,0	85,0	60,0	41.296.40.16.Z	30336160
50x80	2,5 - 16,0	36,0	57,0	49,8	91,0	85,0	60,0	41.296.50.16.Z	30336163

(1) Sealing disc (\varnothing 3,2 mm) installed in drill chuck head, for cooling channel drills \varnothing 4-8 with straight shank according to DIN 6535, Form HA.

(2) Sealing disc (\varnothing 1,8mm) included in scope of delivery, for cooling channel drills \varnothing 2-4 with straight shank according to DIN 6535, Form HA.

(1) Sealing disc (\varnothing 4,2 mm) installed in drill chuck head, for cooling channel drills \varnothing 6-13 with straight shank according to DIN 6535, Form HA.

(2) Sealing disc (\varnothing 2,05 mm) included in scope of delivery, for cooling channel drills \varnothing 3-6 with straight shank according to DIN 6535, Form HA.

(1) Sealing disc (\varnothing 4,2 mm) installed in drill chuck head, for cooling channel drills \varnothing 6-16 with straight shank according to DIN 6535, Form HA.

(2) Sealing disc (\varnothing 2,05 mm) included in scope of delivery, for cooling channel drills \varnothing 3-6 with straight shank according to DIN 6535, Form HA.

Dimensions in mm.

For accessories and spare parts see "Accessories and spare parts" section.

Additional dimensions and special designs available upon request.

CNC precision drill chucks

With 3 adjustable decentralised ball spray nozzles
Cylindrical shank VDI in accordance with ISO 10889-1

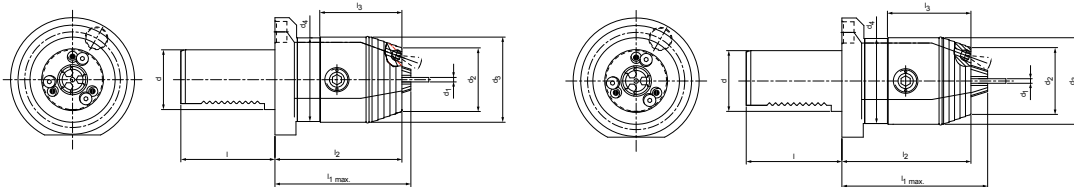

Available on request

DIN ISO 10889-1	Dimensions							Order designation	Order no.
	Clamping range d_1	d_2	d_3	d_4	$l_1 \text{ max.}$	l_2	l_3		
16x32	0,3 - 8,0	29,0	40,0	39,8	63,0	60,0	42,0	47.296.16.08	30336165
20x40	0,3 - 8,0	29,0	40,0	39,8	63,0	60,0	42,0	47.296.20.08	30336166
25x48	0,3 - 8,0	29,0	40,0	39,8	63,0	60,0	42,0	47.296.25.08	30336168
30x55	0,3 - 8,0	29,0	40,0	39,8	63,0	60,0	42,0	47.296.30.08	30336171
40x63	0,3 - 8,0	29,0	40,0	39,8	68,0	65,0	42,0	47.296.40.08	30336174
20x40	0,5 - 13,0	43,0	57,0	56,0	88,0	82,0	55,0	47.296.20.13	30336167
25x48	0,5 - 13,0	43,0	57,0	56,0	88,0	82,0	55,0	47.296.25.13	30336169
30x55	0,5 - 13,0	43,0	57,0	56,0	88,0	82,0	55,0	47.296.30.13	30336172
40x63	0,5 - 13,0	43,0	57,0	56,0	91,0	85,0	55,0	47.296.40.13	30336175
50x78	0,5 - 13,0	43,0	57,0	56,0	91,0	85,0	55,0	47.296.50.13	30336177
30x55	2,5 - 16,0	44,0	57,0	56,0	93,0	82,0	55,0	47.296.30.16	30336173
40x63	2,5 - 16,0	44,0	57,0	56,0	96,0	85,0	55,0	47.296.40.16	30336176
50x78	2,5 - 16,0	44,0	57,0	56,0	96,0	85,0	55,0	47.296.50.16	30336178
60x94	2,5 - 16,0	44,0	57,0	56,0	104,0	93,0	55,0	47.296.60.16	30336179

Dimensions in mm.

For accessories and spare parts see "Accessories and spare parts" section.
Additional dimensions and special designs available upon request.

CNC precision drill chucks

With centralised coolant outlet

Cylindrical shank VDI in accordance with ISO 10889-1

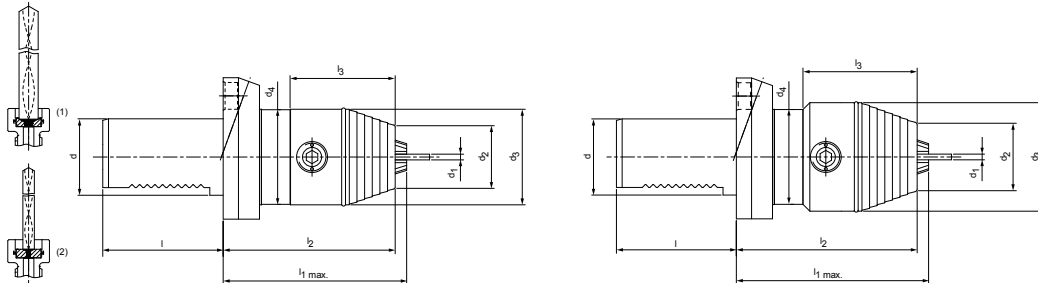

Available on request

DIN ISO 10889-1	Dimensions							Order designation	Order no.
	Clamping range d_1	d_2	d_3	d_4	$l_1 \text{ max.}$	l_2	l_3		
16x32	0,3 - 8,0	23,0	36,0	35,8	71,0	68,0	42,0	48.296.16.08	30336180
20x40	0,3 - 8,0	23,0	36,0	35,8	71,0	68,0	42,0	48.296.20.08	30336181
25x48	0,3 - 8,0	23,0	36,0	35,8	71,0	68,0	42,0	48.296.25.08	30336185
30x55	0,3 - 8,0	23,0	36,0	35,8	71,0	68,0	42,0	48.296.30.08	30336187
40x63	0,3 - 8,0	23,0	36,0	35,8	71,0	68,0	42,0	48.296.40.08	30336194
20x40	0,5 - 13,0	35,0	50,0	49,8	96,0	90,0	50,0	48.296.20.13	30336183
25x48	0,5 - 13,0	35,0	50,0	49,8	96,0	90,0	50,0	48.296.25.13	30336186
30x55	0,5 - 13,0	35,0	50,0	49,8	96,0	90,0	50,0	48.296.30.13	30336189
40x63	0,5 - 13,0	35,0	50,0	49,8	96,0	90,0	50,0	48.296.40.13	30336195
50x78	0,5 - 13,0	35,0	50,0	49,8	96,0	90,0	50,0	48.296.50.13	30336201
30x55	2,5 - 16,0	36,0	57,0	49,8	101,0	95,0	60,0	48.296.30.16	30336192
40x63	2,5 - 16,0	36,0	57,0	49,8	101,0	95,0	60,0	48.296.40.16	30336198
50x78	2,5 - 16,0	36,0	57,0	49,8	101,0	95,0	60,0	48.296.50.16	30336202
60x94	2,5 - 16,0	36,0	57,0	49,8	101,0	95,0	60,0	48.296.60.16	30336203

(1) Sealing disc (\varnothing 3,2 mm) installed in drill chuck head, for cooling channel drills \varnothing 4-8 with straight shank according to DIN 6535, Form HA.

(2) Sealing disc (\varnothing 1,8mm) included in scope of delivery, for cooling channel drills \varnothing 2-4 with straight shank according to DIN 6535, Form HA.

(1) Sealing disc (\varnothing 4,2 mm) installed in drill chuck head, for cooling channel drills \varnothing 6-13 with straight shank according to DIN 6535, Form HA.

(2) Sealing disc (\varnothing 2,05 mm) included in scope of delivery, for cooling channel drills \varnothing 3-6 with straight shank according to DIN 6535, Form HA.

(1) Sealing disc (\varnothing 4,2 mm) installed in drill chuck head, for cooling channel drills \varnothing 6-16 with straight shank according to DIN 6535, Form HA.

(2) Sealing disc (\varnothing 2,05 mm) included in scope of delivery, for cooling channel drills \varnothing 3-6 with straight shank according to DIN 6535, Form HA.

Dimensions in mm.

For accessories and spare parts see "Accessories and spare parts" section.

Additional dimensions and special designs available upon request.

CNC precision drill chucks

Without coolant outlet

Shank PSC according to ISO 26623-1

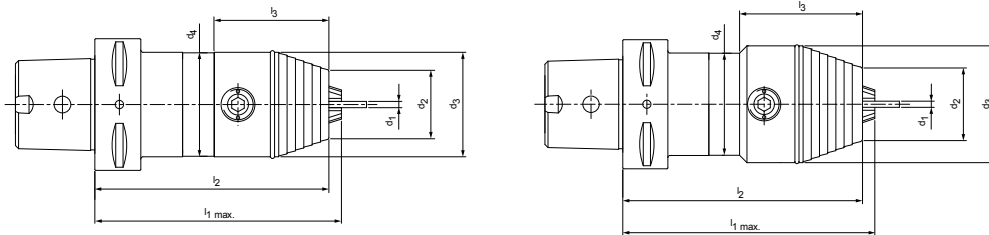

Available on request

PSC	Dimensions							Order designation	Order no.
	Clamping range d_1	d_2	d_3	d_4	$l_1 \text{ max.}$	l_2	l_3		
32	0,3 - 8,0	23,0	36,0	35,8	76,0	73,0	42,0	67.296.32.08	30591623
32	0,5 - 13,0	35,0	50,0	49,8	103,0	96,0	55,0	67.296.32.13	30591627
40	0,3 - 8,0	23,0	36,0	35,8	77,0	74,0	42,0	67.296.40.08	30591631
40	0,5 - 13,0	35,0	50,0	49,8	105,0	98,0	55,0	67.296.40.13	30591633
50	0,3 - 8,0	23,0	36,0	35,8	79,0	76,0	42,0	67.296.50.08	30591635
50	0,5 - 13,0	35,0	50,0	49,8	105,0	97,0	55,0	67.296.50.13	30591636
63	0,3 - 8,0	23,0	36,0	35,8	94,0	91,0	42,0	67.296.63.08	30336230
63	0,5 - 13,0	35,0	50,0	49,8	118,0	112,0	55,0	67.296.63.13	30336232
63	2,5 - 16,0	36,0	57,0	49,8	123,0	117,0	60,0	67.296.63.16	30336234
80	0,5 - 13,0	35,0	50,0	49,8	112,0	106,0	55,0	67.296.80.13	30591638
80	2,5 - 16,0	36,0	57,0	49,8	115,0	111,0	60,0	67.296.80.16	30591639

Dimensions in mm.

For accessories and spare parts see "Accessories and spare parts" section.

Additional dimensions and special designs available upon request.

CNC precision drill chucks

With centralised coolant outlet

Shank PSC according to ISO 26623-1

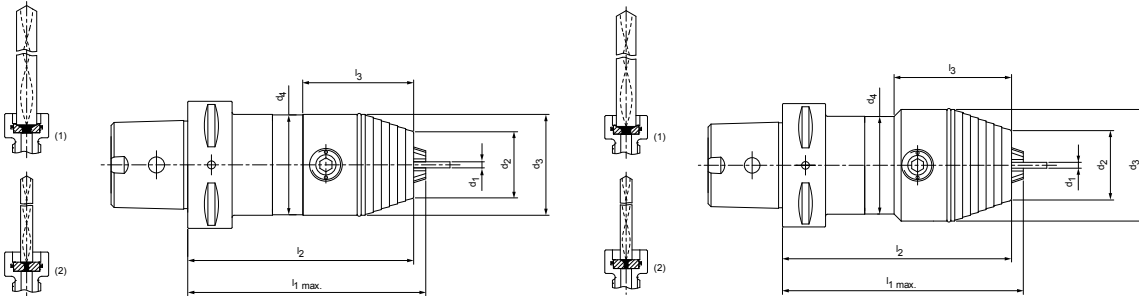

Available on request

PSC	Dimensions							Order designation	Order no.
	Clamping range d_1	d_2	d_3	d_4	$l_1 \text{ max.}$	l_2	l_3		
32	0,3 - 8,0	23,0	36,0	35,8	76,0	73,0	42,0	67.296.32.08.Z	30591641
32	0,5 - 13,0	35,0	50,0	49,8	103,0	96,0	55,0	67.296.32.13.Z	30591645
40	0,3 - 8,0	23,0	36,0	35,8	77,0	74,0	42,0	67.296.40.08.Z	30591647
40	0,5 - 13,0	35,0	50,0	49,8	105,0	98,0	55,0	67.296.40.13.Z	30591650
50	0,3 - 8,0	23,0	36,0	35,8	79,0	76,0	42,0	67.296.50.08.Z	30591669
50	0,5 - 13,0	35,0	50,0	49,8	105,0	97,0	55,0	67.296.50.13.Z	30591670
63	0,3 - 8,0	23,0	36,0	35,8	94,0	91,0	42,0	67.296.63.08.Z	30336231
63	0,5 - 13,0	35,0	50,0	49,8	118,0	112,0	55,0	67.296.63.13.Z	30336233
63	2,5 - 16,0	36,0	57,0	49,8	123,0	117,0	60,0	67.296.63.16.Z	30336235
80	0,5 - 13,0	35,0	50,0	49,8	112,0	106,0	55,0	67.296.80.13.Z	30591673
80	2,5 - 16,0	36,0	57,0	49,8	115,0	111,0	60,0	67.296.80.16.Z	30591674

(1) Sealing disc WTE 08 (\varnothing 3.2 mm) installed in drill chuck head, for cooling channel drills \varnothing 4-8 mm with straight shank according to DIN 6535, Form HA.

(2) Sealing disc WTE 08 (\varnothing 1.8mm) included in scope of delivery, for cooling channel drills \varnothing 2-4 mm with straight shank according to DIN 6535, Form HA.

(1) Sealing disc WTE 13 (\varnothing 4.2 mm) installed in drill chuck head, for cooling channel drills \varnothing 6-13 mm with straight shank according to DIN 6535, Form HA.

(2) Sealing disc WTE 13 (\varnothing 2.05mm) included in scope of delivery, for cooling channel drills \varnothing 3-6 mm with straight shank according to DIN 6535, Form HA.

(1) Sealing disc WTE 16 (\varnothing 4.2 mm) installed in drill chuck head, for cooling channel drills \varnothing 6-16 mm with straight shank according to DIN 6535, Form HA.

(2) Sealing disc WTE 16 (\varnothing 2.05mm) included in scope of delivery, for cooling channel drills \varnothing 3-6 mm with straight shank according to DIN 6535, Form HA.

Dimensions in mm.

For accessories and spare parts see "Accessories and spare parts" section.

Additional dimensions and special designs available upon request.

Standard NC drill chucks

Without coolant outlet

Shank SK according to DIN 2080 Form A

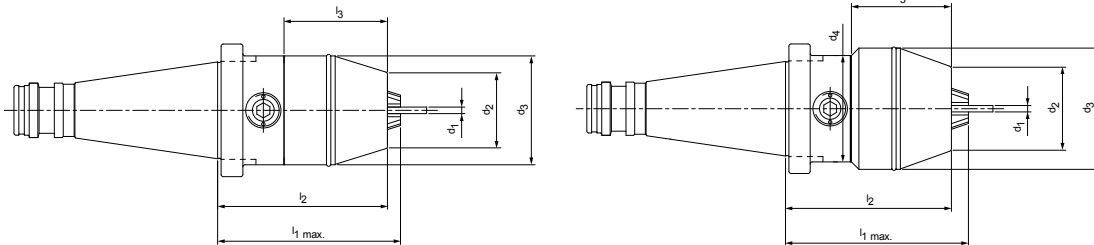

Available on request

SK/ISO	Dimensions							Order designation	Order no.
	Clamping range d ₁	d ₂	d ₃	d ₄	l _{1 max.}	l ₂	l ₃		
40	0,5 - 13,0	35,0	50,0	-	84,0	78,0	47,5	10.297.40.13	30342426
40	2,5 - 16,0	39,5	57,0	50,0	86,0	78,0	47,0	10.297.40.16	30342427

Dimensions in mm.

For accessories and spare parts see "Accessories and spare parts" section.

Additional dimensions and special designs available upon request.

Standard NC drill chucks

Without coolant outlet

Shank SK according to ISO 7388-1 Form AD

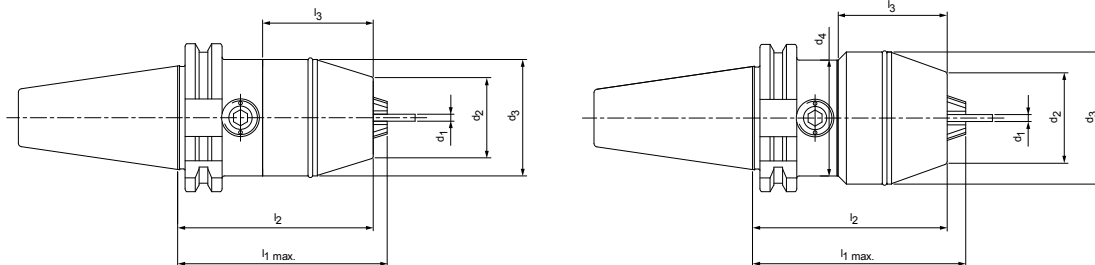

Available on request

SK/ISO	Dimensions							Order designation	Order no.
	Clamping range d_1	d_2	d_3	d_4	l_1 max.	l_2	l_3		
40	0,5 - 13,0	35,0	50,0	-	100,0	94,0	47,5	11.297.40.13	30342428
40	2,5 - 16,0	39,5	57,0	50,0	102,0	94,0	47,0	11.297.40.16	30342429

Dimensions in mm.

For accessories and spare parts see "Accessories and spare parts" section.
Additional dimensions and special designs available upon request.

Standard NC drill chucks

Without coolant outlet

Shank BT according to ISO 7388-2 Form JD (JIS B 6339)

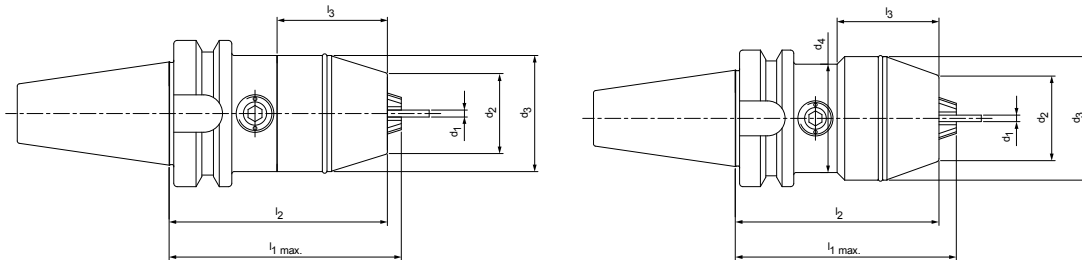

Available on request

BT	Dimensions							Order designation	Order no.
	Clamping range d_1	d_2	d_3	d_4	l_1 max.	l_2	l_3		
40	0,5 - 13,0	35,0	50,0	-	100,0	94,0	47,5	20.297.40.13	30342430
40	2,5 - 16,0	39,5	57,0	50,0	102,0	94,0	47,0	20.297.40.16	30342431

Dimensions in mm.

For accessories and spare parts see "Accessories and spare parts" section.
Additional dimensions and special designs available upon request.

MICRO universal chucks

With centralised coolant outlet

HSK-A (hollow shank taper form A) shank according to DIN 69893-1

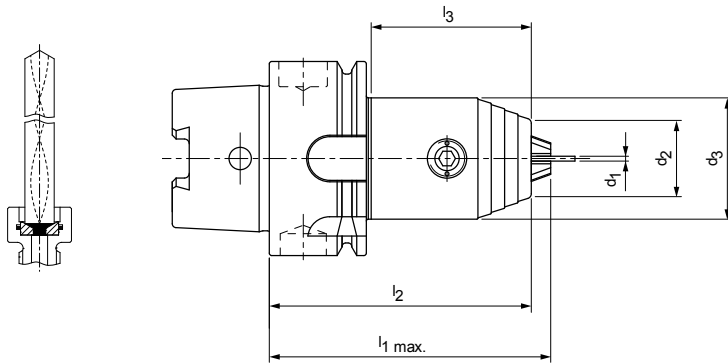

Preferred series available from stock

HSK-A	Dimensions						Order designation	Order no.
	Clamping range d_1	d_2	d_3	l_1 max.	l_2	l_3		
32	0,2 - 3,4	12,5	19,0	49,0	46,0	25,0	16.236.32.03.Z	30439728
32	0,2 - 6,4	16,0	25,0	58,0	54,0	33,0	16.236.32.06.Z	30564811
40	0,2 - 3,4	12,5	19,0	49,0	46,0	25,0	16.236.40.03.Z	30439736
40	0,2 - 6,4	16,0	25,0	58,0	54,0	33,0	16.236.40.06.Z	30564819
50	0,2 - 3,4	12,5	19,0	55,0	52,0	25,0	16.236.50.03.Z	30439739
50	0,2 - 6,4	16,0	25,0	65,0	61,0	33,0	16.236.50.06.Z	30564823

Available on request

63	0,2 - 3,4	12,5	19,0	55,0	52,0	25,0	16.236.63.03.Z	30633696
----	-----------	------	------	------	------	------	----------------	----------

Dimensions in mm.

For accessories and spare parts see "Accessories and spare parts" section.

Additional dimensions and special designs available upon request.

MICRO universal chucks

With centralised coolant outlet

Shank hollow shank taper E according to DIN 69893-5

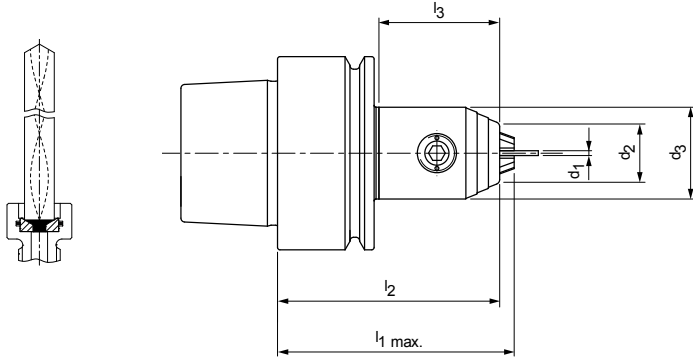

Available on request

HSK-E	Dimensions						Order designation	Order no.
	Clamping range d_1	d_2	d_3	l_1 max.	l_2	l_3		
25	0,2 - 3,4	12,5	19,0	40,0	37,0	25,0	18.236.25.03.Z	30439663
25	0,2 - 6,4	16,0	25,0	64,0	60,0	33,0	18.266.25.06.Z	30564833
32	0,2 - 3,4	12,5	19,0	49,0	46,0	25,0	18.236.32.03.Z	30439686
32	0,2 - 6,4	16,0	25,0	58,0	54,0	33,0	18.266.32.06.Z	30564839
40	0,2 - 3,4	12,5	19,0	49,0	46,0	25,0	18.236.40.03.Z	30439722
40	0,2 - 6,4	16,0	25,0	58,0	54,0	33,0	18.266.40.06.Z	30564844
50	0,2 - 3,4	12,5	19,0	55,0	52,0	25,0	18.236.50.03.Z	30564786

Dimensions in mm.

For accessories and spare parts see "Accessories and spare parts" section.

Additional dimensions and special designs available upon request.

MICRO universal chucks

With centralised coolant outlet

Shank SK according to ISO 7388-1 Form AD

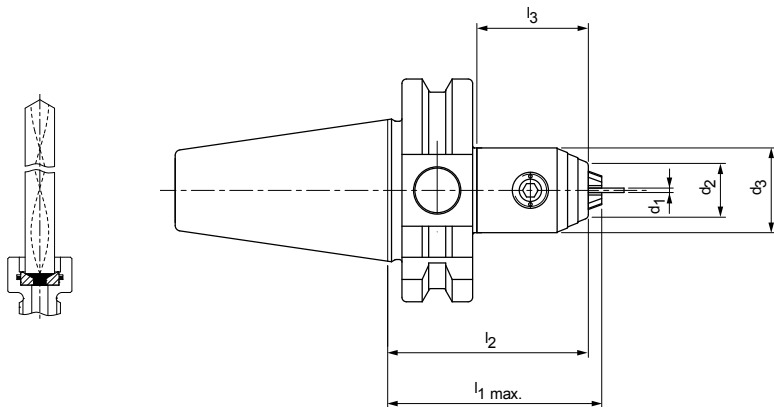

Preferred series available from stock

Steep taper	Dimensions						Order designation	Order no.
	Clamping range d_1	d_2	d_3	l_1	l_2	l_3		
30	0,2 - 3,4	12,5	19,0	48,0	45,0	25,0	15.236.30.03.Z	30439744
30	0,2 - 6,4	16,0	25,0	59,0	55,0	33,0	15.266.30.06.Z	30564796

Dimensions in mm.

For accessories and spare parts see "Accessories and spare parts" section.

Additional dimensions and special designs available upon request.

MICRO universal chucks

With centralised coolant outlet

Shank BT according to ISO 7388-2 Form JD (JIS B 6339)

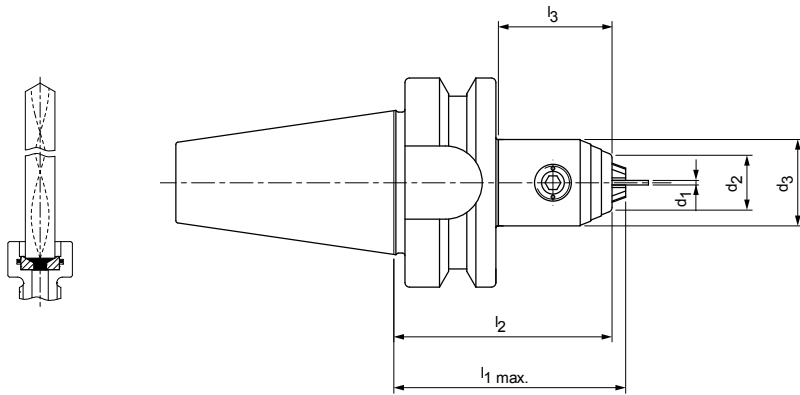

Preferred series available from stock

BT	Dimensions						Order designation	Order no.
	Clamping range d_1	d_2	d_3	$l_1 \text{ max.}$	l_2	l_3		
30	0,2 - 3,4	12,5	19,0	51,0	48,0	25,0	22.236.30.03.Z	30439751
30	0,2 - 6,4	16,0	25,0	62,0	58,0	33,0	22.266.30.06.Z	30564869

Dimensions in mm.

For accessories and spare parts see "Accessories and spare parts" section.

Additional dimensions and special designs available upon request.

MICRO universal chucks

With centralised coolant outlet

With cylindrical shank h6 according to technical details

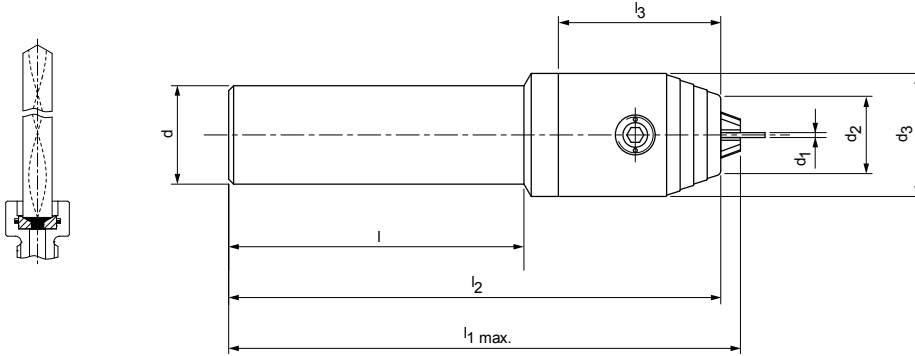

Preferred series available from stock

Cylindrical shank mounting diameter D	Dimensions							Order designation	Order no.
	Clamping range d ₁	d ₂	d ₃	l	l _{1 max.}	l ₂	l ₃		
10	0,2 - 3,4	12,5	19,0	40,0	73,0	70,0	25,0	40.257.10.03.Z	30500299
10	0,2 - 3,4	12,5	19,0	70,0	103,0	100,0	25,0	40.257.10.03.Z/100	30500301
10	0,2 - 3,4	12,5	19,0	130,0	163,0	160,0	25,0	40.257.10.03.Z/160	30500302
16	0,2 - 3,4	12,5	19,0	50,0	83,0	80,0	25,0	40.257.16.03.Z	30439821
16	0,2 - 3,4	12,5	19,0	70,0	130,0	100,0	25,0	40.257.16.03.Z/100	30439832
16	0,2 - 3,4	12,5	19,0	130,0	163,0	160,0	25,0	40.257.16.03.Z/160	30439837
20	0,2 - 3,4	12,5	19,0	80,0	83,0	80,0	25,0	40.257.20.03.Z	30439755
20	0,2 - 3,4	12,5	19,0	100,0	103,0	100,0	25,0	40.257.20.03.Z/100	30439758
20	0,2 - 3,4	12,5	19,0	160,0	163,0	160,0	25,0	40.257.20.03.Z/160	30439763
20	0,2 - 6,4	16,0	25,0	60,0	104,0	100,0	33,0	40.257.20.06.Z/100	30564907
20	0,2 - 6,4	16,0	25,0	110,0	154,0	150,0	33,0	40.257.20.06.Z/150	30565004
20	0,2 - 6,4	16,0	25,0	160,0	204,0	200,0	33,0	40.257.20.06.Z/200	30565008

Available on request

Nominal size Shank	Dimensions						Order designation	Order no.
	Clamping range d ₁	d ₃	d ₂	l ₂	l ₁	l		
16	0,2 - 6,4	25,0	16,0	100,0	104,0	60,0	40.257.16.06.Z	30564901
16	0,2 - 6,4	25,0	16,0	150,0	154,0	110,0	40.257.16.06.Z/150	30564903
16	0,2 - 6,4	25,0	16,0	200,0	204,0	160,0	40.257.16.06.Z/200	30564905
20	0,2 - 6,4	25,0	20,0	100,0	104,0	60,0	40.257.20.06.Z	30564907
20	0,2 - 6,4	25,0	20,0	150,0	154,0	110,0	40.257.20.06.Z/150	30565004
20	0,2 - 6,4	25,0	20,0	200,0	204,0	160,0	40.257.20.06.Z/200	30565008

Dimensions in mm.

For accessories and spare parts see "Accessories and spare parts" section.
Additional dimensions and special designs available upon request.



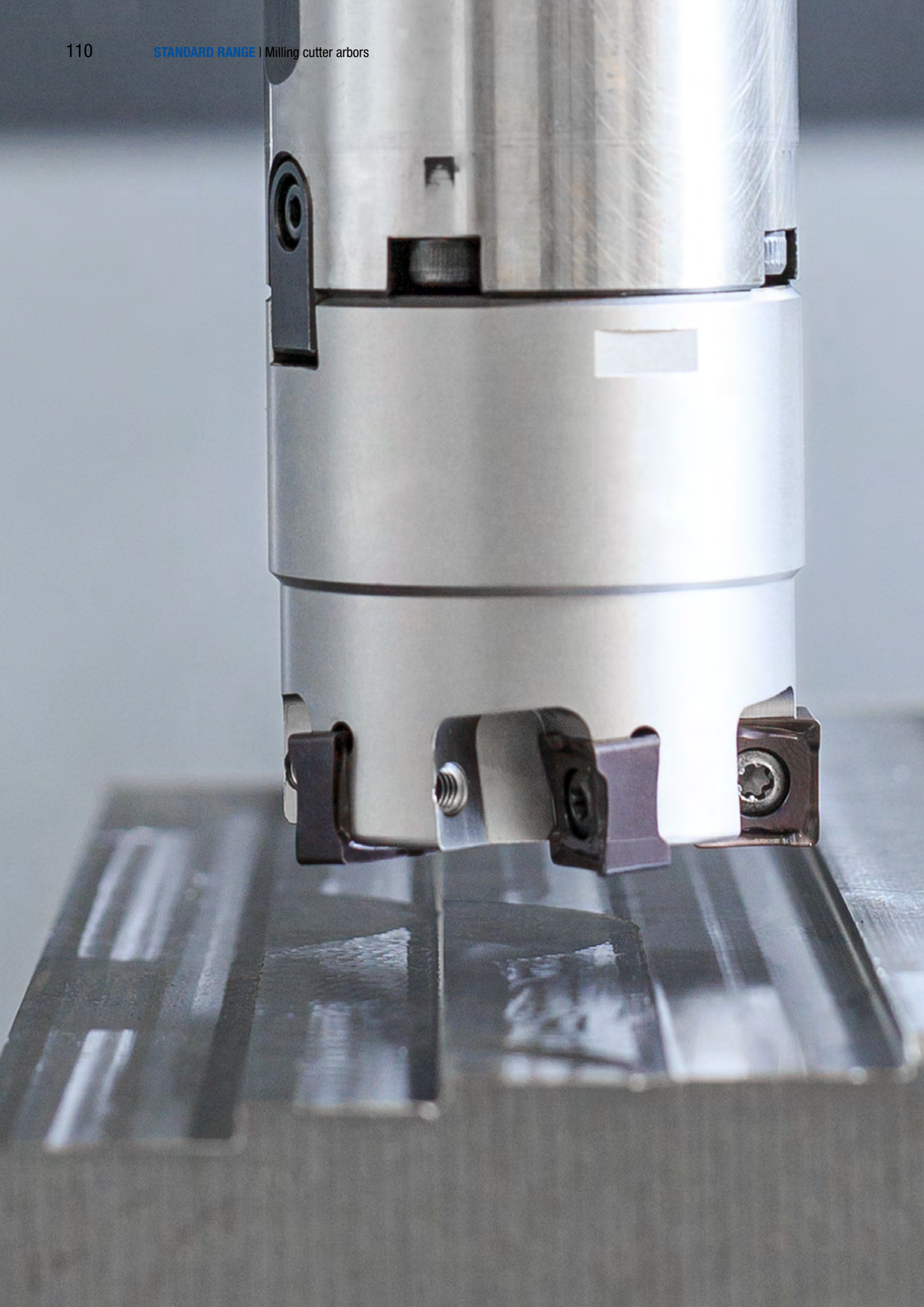

MILLING CUTTER ARBOR

Standard and vibration dampened design

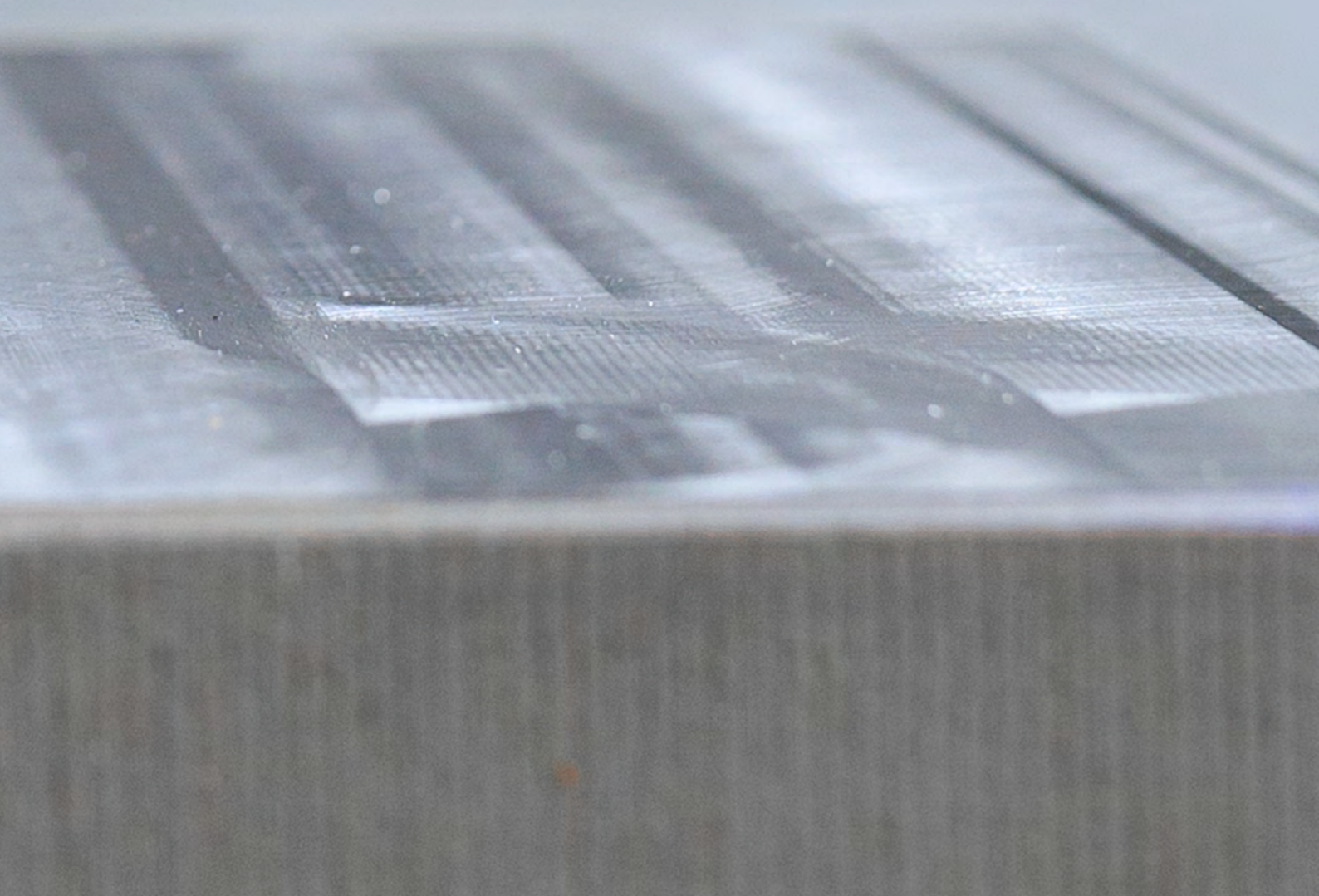



MILLING CUTTER ARBOR

Milling cutter arbor

Vibration dampened design _____ 114



VIBRATION DAMPENING

Significantly better surfaces

Vibrations often occur during machining. They cause the system to become dynamically unstable. This can result in unacceptable surface finish, insufficient accuracy, high levels of machining noise, shortened tool life, and broken tools and cutting edges in extreme cases.

To minimise these vibrations and their consequences, WTE has developed an innovative system for vibration dampening in the tool shank. In particular, tools for boring and milling with very long projections tend to vibrate due to the insufficient dynamic rigidity of the overall system. When designing the new system, the developers took into account all the factors resulting from the interaction between the machine tool, the tool and its clamp, and the part. The result: a vi-

bration dampening system that is calibrated to the rigidity of all common machine types. It can be used for the machining of a range of workpiece materials with various different tools.

The self-contained system made of auxiliary mass and several steel spring packages counteracts and minimises the displacement of the tool body. Compared to tools without an absorber system, the vibration amplitudes can be up to 1,000 times lower. As such, a smooth, stable run is achieved even with long projections. This allows higher cutting speeds to be used and the material removal rate to be significantly increased. In addition, considerably better surface finishes are achieved thanks to the vibration dampening.

AT A GLANCE

- System for vibration dampening in tools with long projections directly in the tool shank
- Adapted to the rigidity of all common machine types
- Available with internal coolant supply for the clamping diameters 16, 22 and 27 mm with a length of 200 and 300 mm for the SK40, SK50, HSK-A63 and HSK-A100 connections

ADVANTAGES

- Smooth, stable running despite long projections
- Higher cutting speeds, higher material removal rate
- Better surface qualities

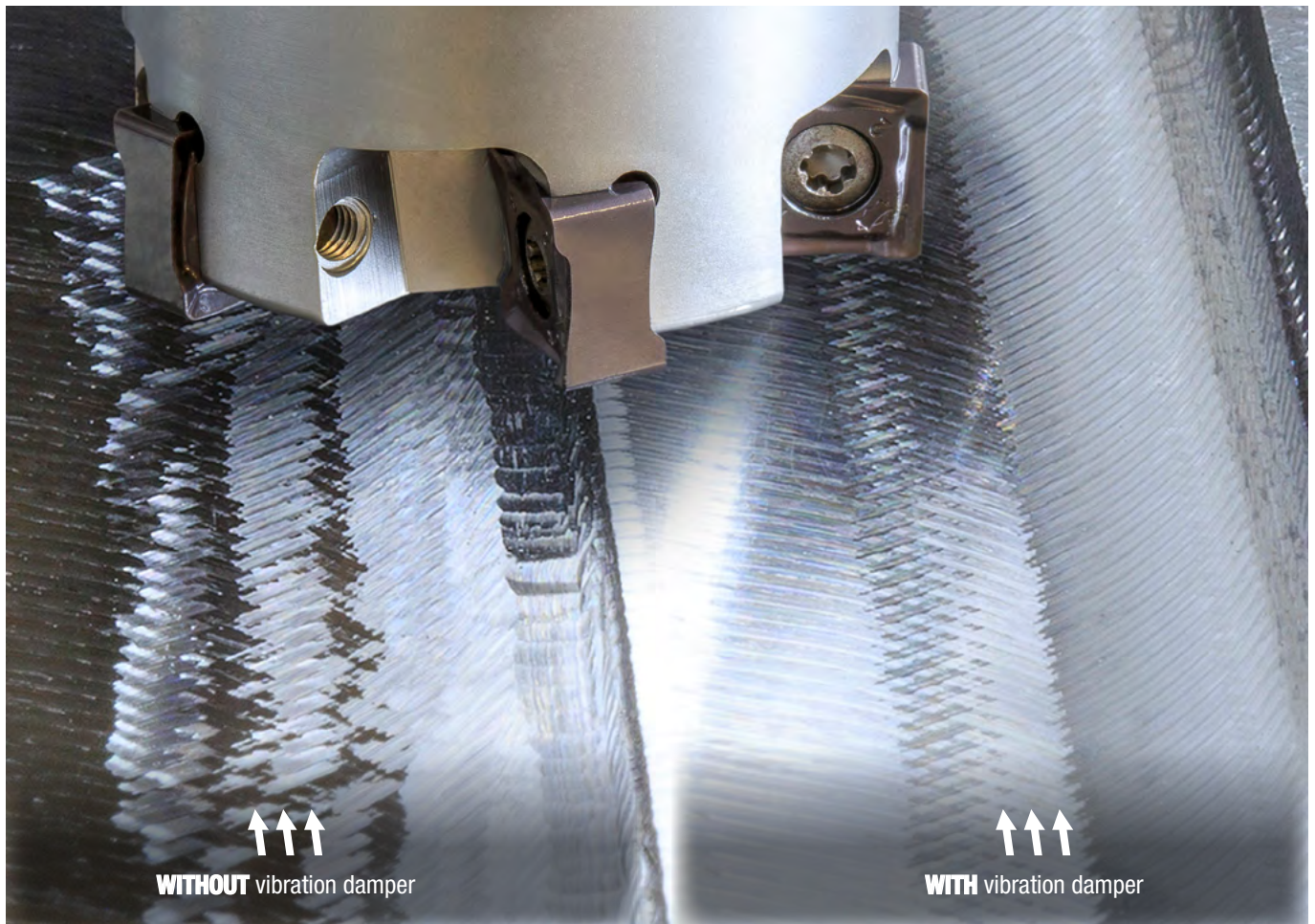

Tool features in detail

1 Internal coolant supply channels

- Optimum coolant supply

2 Standardised connection according to DIN 69882-3

- Suitable for standard milling cutters with cross slot

3 Hard turned surface

- Improved corrosion resistance

4 Cylindrical contour

- Optimum accessibility



Vibration dampening in the milling cutter arbor

- Smooth, stable running despite long projections
- Protection of spindle and machine with lower energy consumption than with an undamped system
- Noise is minimised in the machining process



Internal coolant supply

- Internal cooling enables higher cutting speeds with better material removal rates
- Less blade chipping
- Optimal cooling of the cutting edge also makes deep machining positions possible

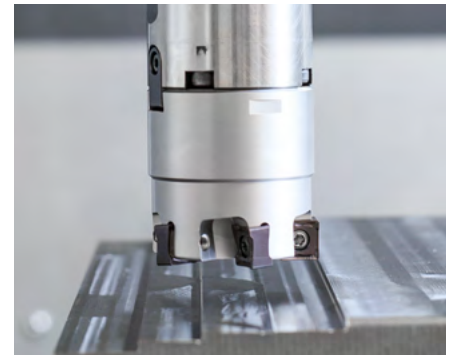

Better surface qualities thanks to vibration dampening

- Significantly improved surface with identical cutting data compared to undamped systems
- Optimum chip breaking, surfaces are not scratched

Milling cutter arbor

Mechanical tool clamping, for milling cutters with cross slot according to DIN 69882-3
 HSK-A (hollow shank taper form A) shank according to DIN 69893-1

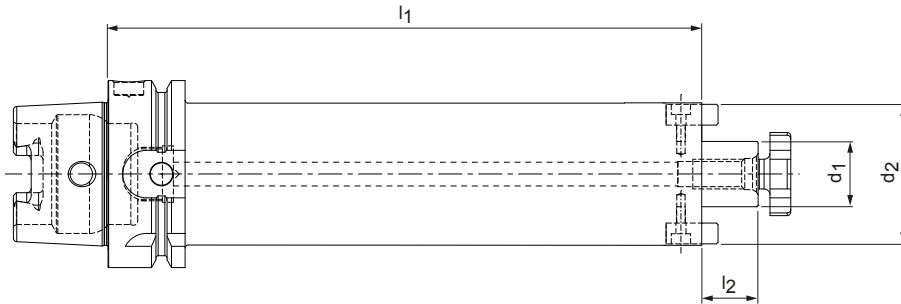

Vibration dampened design | Preferred series available from stock

HSK-A	Dimensions				Order designation	Order no.
	d_1	d_2	l_1	l_2		
63	16,0	38,0	200,0	17,0	16.276.63.16.Z	30905966
63	16,0	38,0	300,0	17,0	16.276.63.16.Z	30906060
63	22,0	48,0	200,0	19,0	16.276.63.22.Z	30905970
63	22,0	48,0	300,0	19,0	16.276.63.22.Z	30905972
100	16,0	38,0	200,0	17,0	16.276.100.16.Z	30905975
100	16,0	38,0	300,0	17,0	16.276.100.16.Z	30905984
100	22,0	48,0	200,0	19,0	16.276.100.22.Z	30905979
100	22,0	48,0	300,0	19,0	16.276.100.22.Z	30906175
100	27,0	58,0	200,0	21,0	16.276.100.27.Z	30905981
100	27,0	58,0	300,0	21,0	16.276.100.27.Z	30905986

Technical data of the milling cutter arbor with hollow shank taper connection

Order no.	Max. operating speed [rpm]	Recommended weight for milling cutter [kg]	Total mass [kg]	Moment of tilt with milling cutter nominal weight [Nm]	Permissible transferable torque [Nm]	Max. cutting force [N]
30905966	8.000	0,2 ($\pm 0,1$)	2,3	1,89	200	1.300
30906060	5.000	0,2 ($\pm 0,1$)	3,2	4,22	200	900
30905970	8.000	0,6 ($\pm 0,15$)	3,5	4,08	270	1.300
30905972	5.500	0,6 ($\pm 0,15$)	4,9	8,32	270	900
30905975	8.000	0,2 ($\pm 0,1$)	3,6	1,57	200	3.400
30905984	5.800	0,2 ($\pm 0,1$)	4,5	3,95	200	2.400
30905979	8.000	0,6 ($\pm 0,15$)	4,7	3,65	270	3.400
30906175	6.000	0,6 ($\pm 0,15$)	6,0	7,61	270	2.400
30905981	8.000	0,9 ($\pm 0,2$)	5,8	5,23	500	3.400
30905986	6.000	0,9 ($\pm 0,2$)	8,0	11,37	500	2.400

Dimensions in mm.

For accessories and spare parts, see end of section.

Additional dimensions and special designs available upon request.

Milling cutter arbor

Mechanical tool clamping, for milling cutters with cross slot according to DIN 69882-3
SK shank according to ISO 7388-1 Form AD/AF

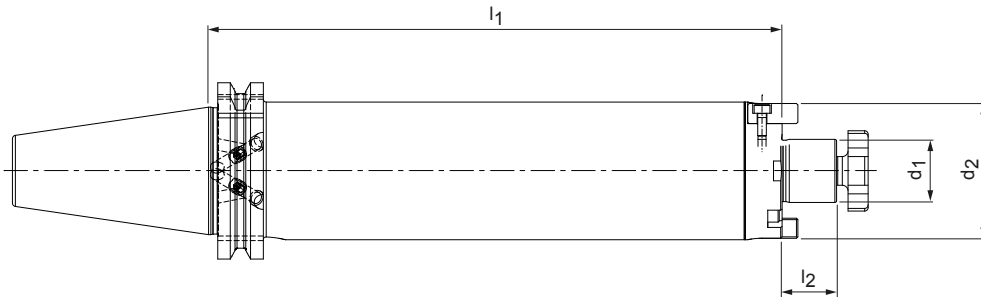

Vibration dampened design | Preferred series available from stock

Steep taper	Dimensions				Order designation	Order no.
	d ₁	d ₂	l ₁	l ₂		
40	16,0	38,0	200,0	17,0	15.276.40.16.Z	30905993
40	16,0	38,0	300,0	17,0	15.276.40.16.Z	30905996
40	22,0	48,0	200,0	19,0	15.276.40.22.Z	30905995
40	22,0	48,0	300,0	19,0	15.276.40.22.Z	30977074
50	16,0	38,0	200,0	17,0	15.276.50.16.Z	30905997
50	16,0	38,0	300,0	17,0	15.276.50.16.Z	30906000
50	22,0	48,0	200,0	19,0	15.276.50.22.Z	30905998
50	22,0	48,0	300,0	19,0	15.276.50.22.Z	30906003
50	27,0	58,0	200,0	21,0	15.276.50.27.Z	30905999
50	27,0	58,0	300,0	21,0	15.276.50.27.Z	30906007

Technical data of the milling cutter arbor with steep taper connection

Order no.	Max. operating speed [rpm]	Recommended weight for milling cutter [kg]	Total mass [kg]	Moment of tilt with milling cutter nominal weight [Nm]	Permissible transferable torque [Nm]	Max. cutting force [N]
30905993	8.000	0,2 (±0,1)	2,5	1,90	200	650
30905996	4.500	0,2 (±0,1)	3,4	4,32	200	450
30905995	5.500	0,6 (±0,15)	3,7	4,19	270	650
30977074	3.500	0,6 (±0,15)	5,1	8,85	270	450
30905997	8.000	0,2 (±0,1)	4,2	1,22	200	1.700
30906000	6.000	0,2 (±0,1)	5,1	3,67	200	1.200
30905998	8.000	0,6 (±0,15)	5,3	3,34	270	1.700
30906003	5.500	0,6 (±0,15)	6,9	7,87	270	1.200
30905999	8.000	0,9 (±0,2)	6,6	5,13	500	1.700
30906007	5.000	0,9 (±0,2)	8,8	11,59	500	1.200

Dimensions in mm.

For accessories and spare parts, see end of section.

Additional dimensions and special designs available upon request.

Spare parts for milling cutter arbors

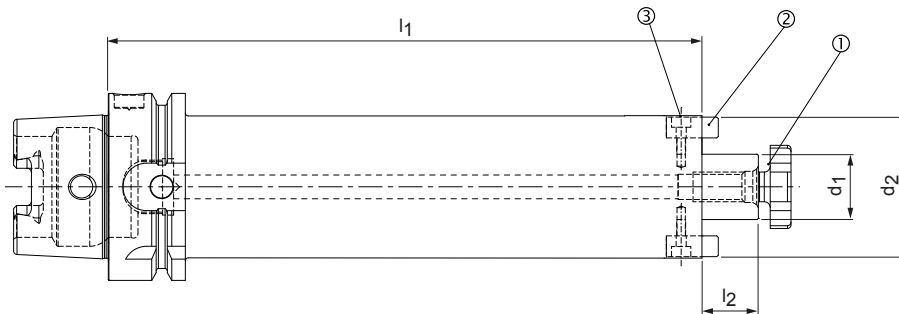

For milling cutter arbors with enlarged face connection diameter according to DIN 69882-3

Connection hollow shank taper-A	For arbor diameter d_1	① Milling cutter clamping screw according to DIN 6367		② Key block (2x)		③ Cylinder screw according to ISO 4762 (2x)	
		Size	Order no.	Size	Order no.	Size	Order no.
63	16	M12	10005164	12x10x20	30924965	M4x12-12.9	10003584
63	22	M10	10006016	10x7x17.5	30924964	M3x8-12.9	10003570
100	16	M12	10005164	12x10x20	30924965	M4x12-12.9	10003584
100	22	M10	10006016	10x7x17.5	30924964	M3x8-12.9	10003570
100	27	M8	10007286	8x7x16	30924963	M3x8-12.9	10003570

For milling cutter arbors with enlarged face connection diameter according to DIN 69882-3

Connection SK	For arbor diameter d_1	① Milling cutter clamping screw according to DIN 6367		② Key block (2x)		③ Cylinder screw according to ISO 4762 (2x)	
		Size	Order no.	Size	Order no.	Size	Order no.
40	16	M12	10005164	12x10x20	30924965	M4x12-12.9	10003584
40	22	M10	10006016	10x7x17.5	30924964	M3x8-12.9	10003570
50	16	M12	10005164	12x10x20	30924965	M4x12-12.9	10003584
50	22	M10	10006016	10x7x17.5	30924964	M3x8-12.9	10003570
50	27	M8	10007286	8x7x16	30924963	M3x8-12.9	10003570



EXTENSIONS AND ADAPTERS



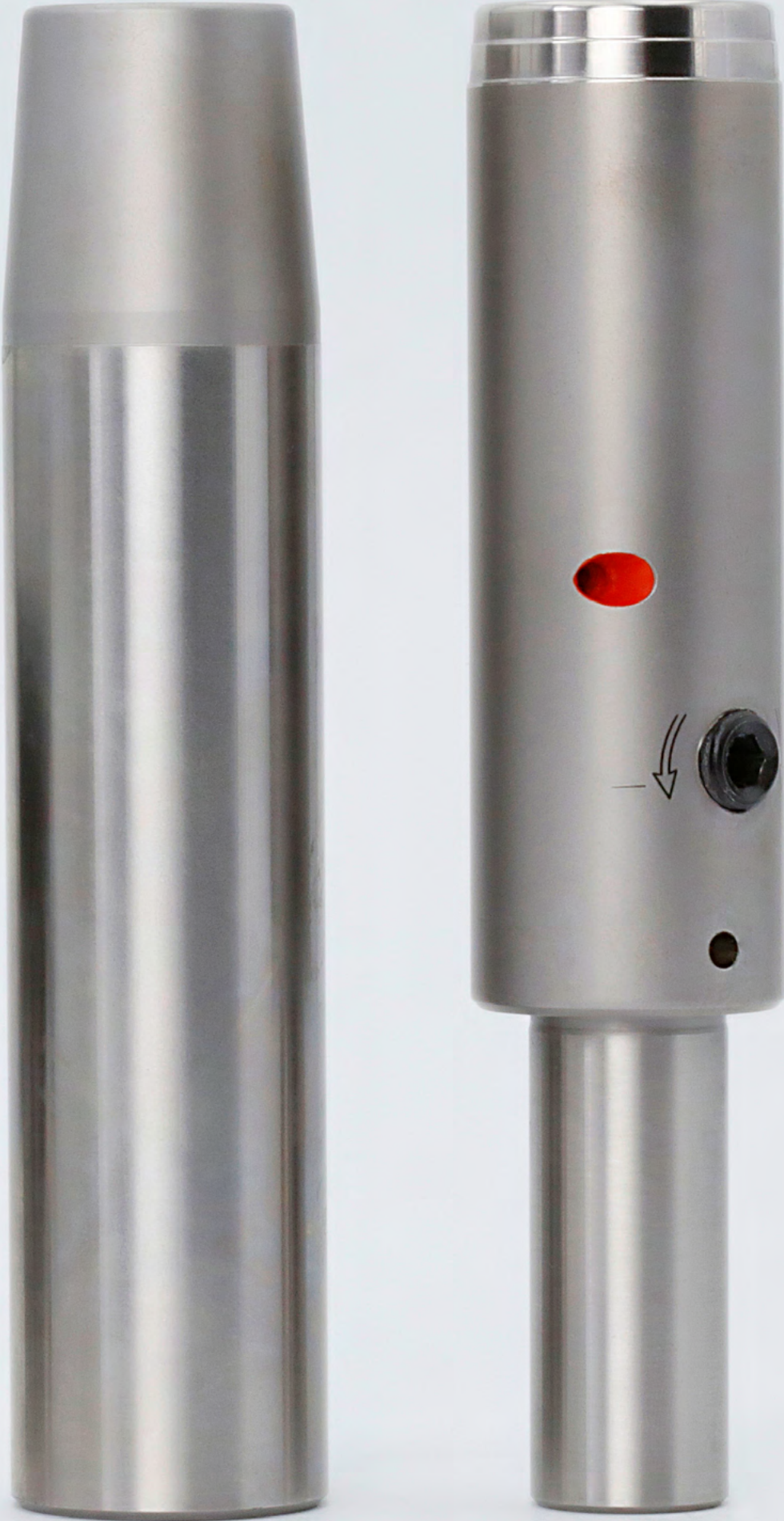

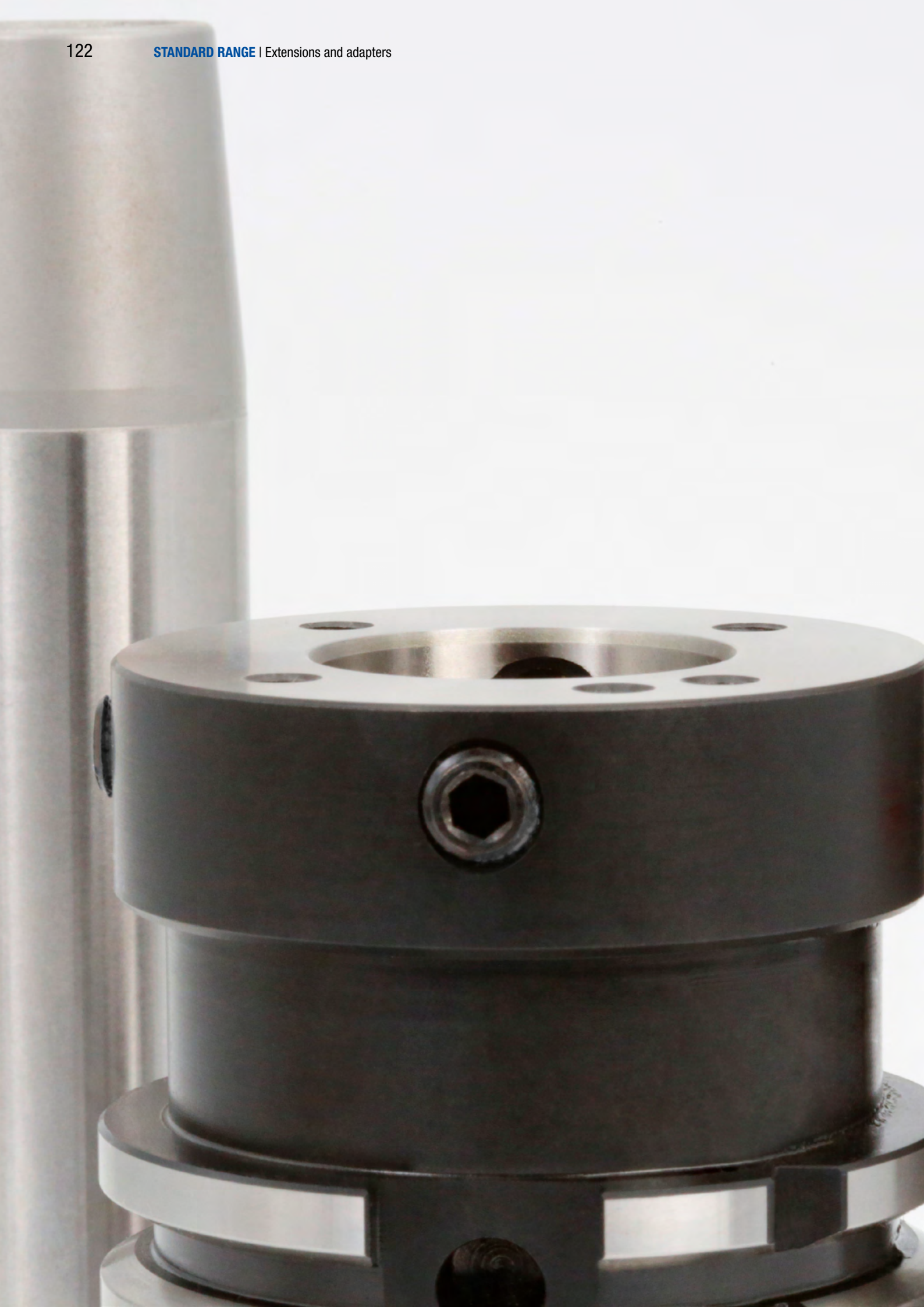

EXTENSIONS AND ADAPTERS

Introduction

Product overview	124
------------------------	-----

Extensions

Hydraulic extensions	126
Shrink-fit extensions	127

Adapters

Hollow shank taper adapters	128
Steep taper adapters	129



PRODUCT OVERVIEW

Extensions and adapters

To enable further projection lengths, WTE offers hydraulic extensions and shrink-fit extensions in various designs and diameters. In this way, standard tools can be flexibly extended.

WTE offers adapters for use in the machine spindle for mounting KS flange adapters, shrink chucks, hydraulic chucks, chucks for cylindrical shanks or tools with a module shank for HSK | SK | BT connections.



Extensions



Hydraulic extensions

- For clamping tools with smooth cylindrical shanks directly and without a reducing sleeve in the clamping diameter
- With axial tool length adjustment $d_1 = 20 | 32$



Shrink-fit extensions

- With axial tool length adjustment from clamping diameter $d_1 = 6$ mm
- $d_1 = 12 | 16 | 20 | 25 | 32$



Adapter



HSK adapter

- Hollow shank taper-A40 | 50 | 63 | 80 | 100

Steep taper adapters

- For use in the machine spindle
- For connecting chucks or tools with module connection
- SK30 | 40 | 50 – BT30 | 40 | 50

Hydraulic extension

As flexible adaption

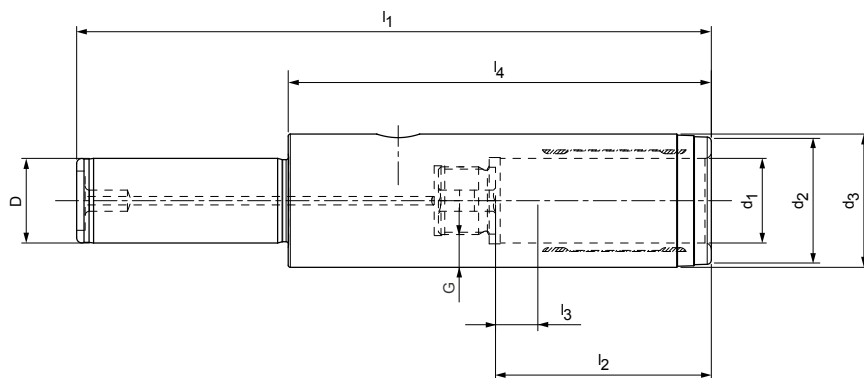

Preferred series available from stock

Cylindrical shank mounting diameter D	Dimensions							G	Order designation	Order no.
	d ₁	d ₂	d ₃	l ₁	l ₂	l ₃	l ₄			
20	12,0	22,0	25,0	150,0	46,0	10,0	100,0	M10x1	40.557.20.12.Z/150	30479021
20	20,0	30,0	31,5	150,0	51,0	10,0	100,0	M16x1	40.557.20.20.Z/150	30479022
32	20,0	30,0	31,5	150,0	51,0	10,0	90,0	M16x1	40.557.32.20.Z/150	30479024
32	20,0	30,0	31,5	200,0	51,0	10,0	90,0	M16x1	40.557.32.20.Z/200	30479025

Dimensions in mm.

For accessories and spare parts see "Accessories and spare parts" section.

Additional dimensions and special designs available upon request.

Shrink-fit extension

As flexible adaption, including length adjustment screw from $\varnothing 6$ mm
Individual shortening of the shank possible according to customer requirements

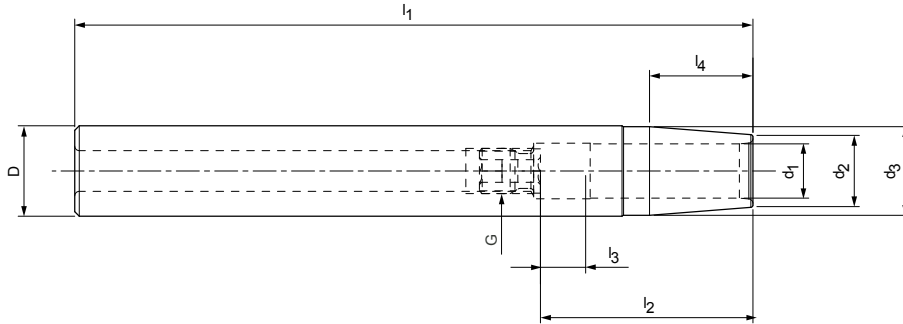

Preferred series available from stock

Cylindrical shank mounting diameter D	Dimensions							G	Order designation	Order no.
	d ₁	d ₂	d ₃	l ₁	l ₂	l ₃	l ₄			
12*	3,0	8,0	11,6	150,0	9,0	-	12,0	-	40.357.12.03.Z/150	30344729
12*	4,0	8,0	11,6	150,0	12,0	-	16,0	-	40.357.12.04.Z/150	30344730
12*	5,0	10,0	11,6	150,0	15,0	-	20,0	-	40.357.12.05.Z/150	30344731
12	6,0	10,0	11,6	150,0	36,0	10,0	26,0	M5	40.357.12.06.Z/150	30344732
16*	3,0	10,0	15,6	150,0	9,0	-	12,0	-	40.357.16.03.Z/150	30344733
16*	4,0	10,0	15,6	150,0	12,0	-	16,0	-	40.357.16.04.Z/150	30344734
16*	5,0	10,0	15,6	150,0	15,0	-	20,0	-	40.357.16.05.Z/150	30344735
16	6,0	10,0	15,6	150,0	36,0	10,0	26,0	M5	40.357.16.06.Z/150	30344736
16	8,0	12,0	15,6	150,0	36,0	10,0	26,0	M6	40.357.16.08.Z/150	30344737
20*	3,0	10,0	19,6	150,0	9,0	-	12,0	-	40.357.20.03.Z/150	30344738
20*	4,0	10,0	19,6	150,0	12,0	-	16,0	-	40.357.20.04.Z/150	30344739
20*	5,0	10,0	19,6	150,0	15,0	-	20,0	-	40.357.20.05.Z/150	30344740
20	6,0	10,0	19,6	150,0	36,0	10,0	26,0	M5	40.357.20.06.Z/150	30344741
20	8,0	12,0	19,6	150,0	36,0	10,0	26,0	M6	40.357.20.08.Z/150	30344742
20	10,0	14,0	19,6	150,0	42,0	10,0	32,0	M8x1	40.357.20.10.Z/150	30344743
20	12,0	16,0	19,6	150,0	47,0	10,0	37,0	M10x1	40.357.20.12.Z/150	30344744
25	6,0	20,0	24,6	150,0	36,0	10,0	26,0	M5	40.357.25.06.Z/150	30344748
25	8,0	20,0	24,6	150,0	36,0	10,0	26,0	M6	40.357.25.08.Z/150	30344749
25	10,0	20,0	24,6	150,0	42,0	10,0	32,0	M8x1	40.357.25.10.Z/150	30344750
25	12,0	20,0	24,6	150,0	47,0	10,0	37,0	M10x1	40.357.25.12.Z/150	30344751
25	14,0	20,0	24,6	150,0	47,0	10,0	37,0	M10x1	40.357.25.14.Z/150	30344752
25	16,0	22,0	24,6	150,0	50,0	10,0	40,0	M10x1	40.357.25.16.Z/150	30344753
32	6,0	20,0	29,0	150,0	36,0	10,0	26,0	M5	40.357.32.06.Z/150	30344754
32	8,0	20,0	29,0	150,0	36,0	10,0	26,0	M6	40.357.32.08.Z/150	30344755
32	10,0	24,0	31,6	150,0	42,0	10,0	32,0	M8x1	40.357.32.10.Z/150	30344756
32	12,0	24,0	31,6	150,0	47,0	10,0	37,0	M10x1	40.357.32.12.Z/150	30344757
32	14,0	27,0	31,6	150,0	47,0	10,0	37,0	M10x1	40.357.32.14.Z/150	30344758
32	16,0	27,0	31,6	150,0	50,0	10,0	40,0	M10x1	40.357.32.16.Z/150	30344759
32	18,0	27,0	31,6	150,0	50,0	10,0	40,0	M10x1	40.357.32.18.Z/150	30337832
32	20,0	27,0	31,6	150,0	52,0	10,0	42,0	M10x1	40.357.32.20.Z/150	30337833

* Without axial length adjustment screw

Dimensions in mm.

For accessories and spare parts see "Accessories and spare parts" section.
Additional dimensions and special designs available upon request.

Modular hollow shank taper-A adapters

HSK-A (hollow shank taper form A) shank according to DIN 69893-1

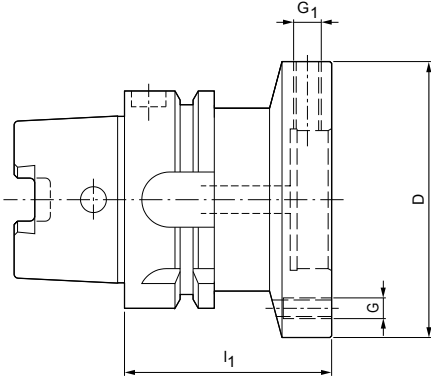

HSK-A	Module diameter D	Dimensions			Order designation	Order no.
		l ₁	G	G ₁		
40	60,0	60,0	M5	M8x1	16.150.40.60.Z/60	30615827
50	60,0	60,0	M5	M8x1	16.150.50.60.Z/60	30584456
50	70,0	60,0	M6	M8x1	16.150.50.70.Z/60	30584465
50	80,0	60,0	M6	M8x1	16.150.50.80.Z/60	30584469
63	60,0	60,0	M5	M8x1	16.150.63.60.Z/60	30584473
63	70,0	60,0	M6	M8x1	16.150.63.70.Z/60	30584477
63	80,0	60,0	M6	M8x1	16.150.63.80.Z/60	30584478
63	100,0	65,0	M8	M10x1	16.150.63.100.Z/65	30584481
63	117,0	65,0	M8	M10x1	16.150.63.117.Z/65	30584482
80	60,0	50,0	M5	M8x1	16.150.80.60.Z/50	30584487
80	70,0	60,0	M6	M8x1	16.150.80.70.Z/60	30584489
80	80,0	60,0	M6	M8x1	16.150.80.80.Z/60	30584490
80	100,0	65,0	M8	M10x1	16.150.80.100.Z/65	30584491
80	117,0	65,0	M8	M10x1	16.150.80.117.Z/65	30584492
80	140,0	75,0	M10	M10x1	16.150.80.140.Z/75	30584493
100	60,0	55,0	M5	M8x1	16.150.100.60.Z/55	30584495
100	70,0	55,0	M6	M8x1	16.150.100.70.Z/55	30584497
100	80,0	55,0	M6	M8x1	16.150.100.80.Z/55	30584498
100	100,0	65,0	M8	M10x1	16.150.100.100.Z/65	30584499
100	117,0	65,0	M8	M10x1	16.150.100.117.Z/65	30584500
100	140,0	75,0	M10	M10x1	16.150.100.140.Z/75	30584502

Spare parts

For module diameter D	Quantity required	① Threaded pin		
		Size		Order no.
60 - 80	4	M8x1x16		10075355
100 - 140	4	M10x1x20	K2865-34	10075099

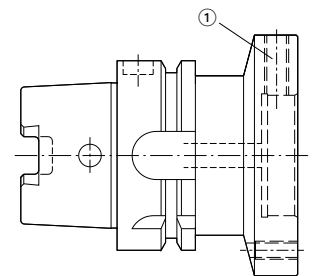

Dimensions in mm.

For spare parts, see product page. For accessories, see "Accessories and spare parts" section.
Additional dimensions and special designs available upon request.

Modular steep taper adapter SK

SK shank according to ISO 7388-1 Form AD/AF

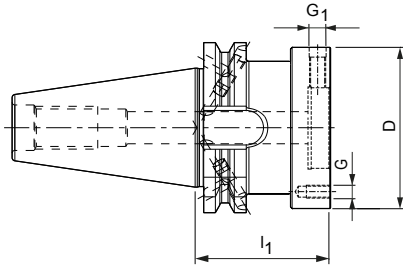

Steep taper	Module diameter D	Dimensions			Order designation	Order no.
		l_1	G	G_1		
30*	60,0	50,0	M5	M8x1	15.150.30.AD.60.Z/50	30584676
30*	60,0	50,0	M5	M8x1	15.150.30.B.60.Z/50	30584681
30*	70,0	50,0	M6	M8x1	15.150.30.AD.70.Z/50	30584682
30*	70,0	50,0	M6	M8x1	15.150.30.B.70.Z/50	30584683
40	60,0	50,0	M5	M8x1	15.150.40.60.Z/50	30584684
40	70,0	50,0	M6	M8x1	15.150.40.70.Z/50	30584685
40	80,0	55,0	M6	M8x1	15.150.40.80.Z/55	30584686
40	100,0	60,0	M8	M10x1	15.150.40.100.Z/60	30584689
50	60,0	50,0	M5	M8x1	15.150.50.60.Z/50	30584700
50	70,0	50,0	M6	M8x1	15.150.50.70.Z/50	30584701
50	80,0	50,0	M6	M8x1	15.150.50.80.Z/50	30584720
50	100,0	60,0	M8	M10x1	15.150.50.100.Z/60	30584721
50	117,0	60,0	M8	M10x1	15.150.50.117.Z/60	30584723
50	140,0	60,0	M10	M10x1	15.150.50.140.Z/60	30584724

* Taper shank size SK30 is not available in combined design AD/AF.

Spare parts

SK nominal size	Quantity required	① Threaded pin	
		Size	Order no.
40 - 50	2	M5x5	10036757

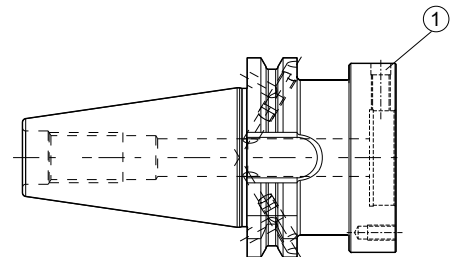

Dimensions in mm.

For spare parts, see product page. For accessories, see "Accessories and spare parts" section.
Additional dimensions and special designs available upon request.

Modular steep taper adapter BT in accordance with ISO 7388-2

Shank BT according to ISO 7388-2 Form JD (JIS B 6339)

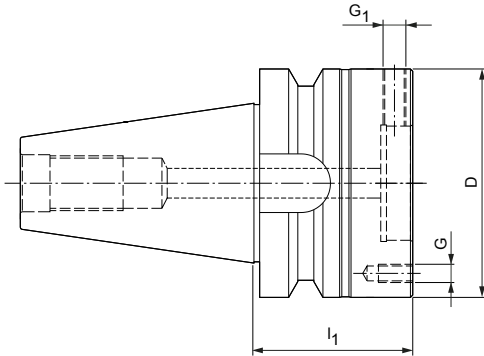

BT	Module diameter D	Dimensions			Order designation	Order no.
		l ₁	G	G ₁		
30	60,0	40,0	M5	M8x1	22.150.30.60.Z/40	30584725
30	70,0	40,0	M6	M8x1	22.150.30.70.Z/40	30584726
40	60,0	55,0	M5	M8x1	22.150.40.60.Z/55	30584734
40	70,0	55,0	M6	M8x1	22.150.40.70.Z/55	30584736
40	80,0	65,0	M6	M8x1	22.150.40.80.Z/65	30584751
40	100,0	70,0	M8	M10x1	22.150.40.100.Z/70	30584752
50	60,0	70,0	M5	M8x1	22.150.50.60.Z/70	30584764
50	70,0	70,0	M6	M8x1	22.150.50.70.Z/70	30584765
50	80,0	70,0	M6	M8x1	22.150.50.80.Z/70	30584767
50	100,0	70,0	M8	M10x1	22.150.50.100.Z/70	30584769
50	117,0	80,0	M8	M10x1	22.150.50.117.Z/80	30584770
50	140,0	80,0	M10	M10x1	22.150.50.140.Z/80	30584772

Spare parts

For module diameter D	Quantity required	① Threaded pin	
		Size	Order no.
60 - 80	4	M8x1x16	10075355
100	4	M10x1x20	10075099
117	4	M10x1x20	10075099
140	4	M10x1x20	10075099

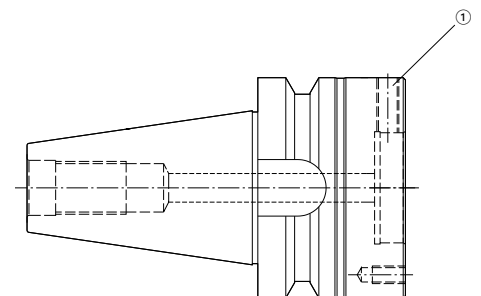

Dimensions in mm.

For spare parts, see product page. For accessories, see "Accessories and spare parts" section.
Additional dimensions and special designs available upon request.

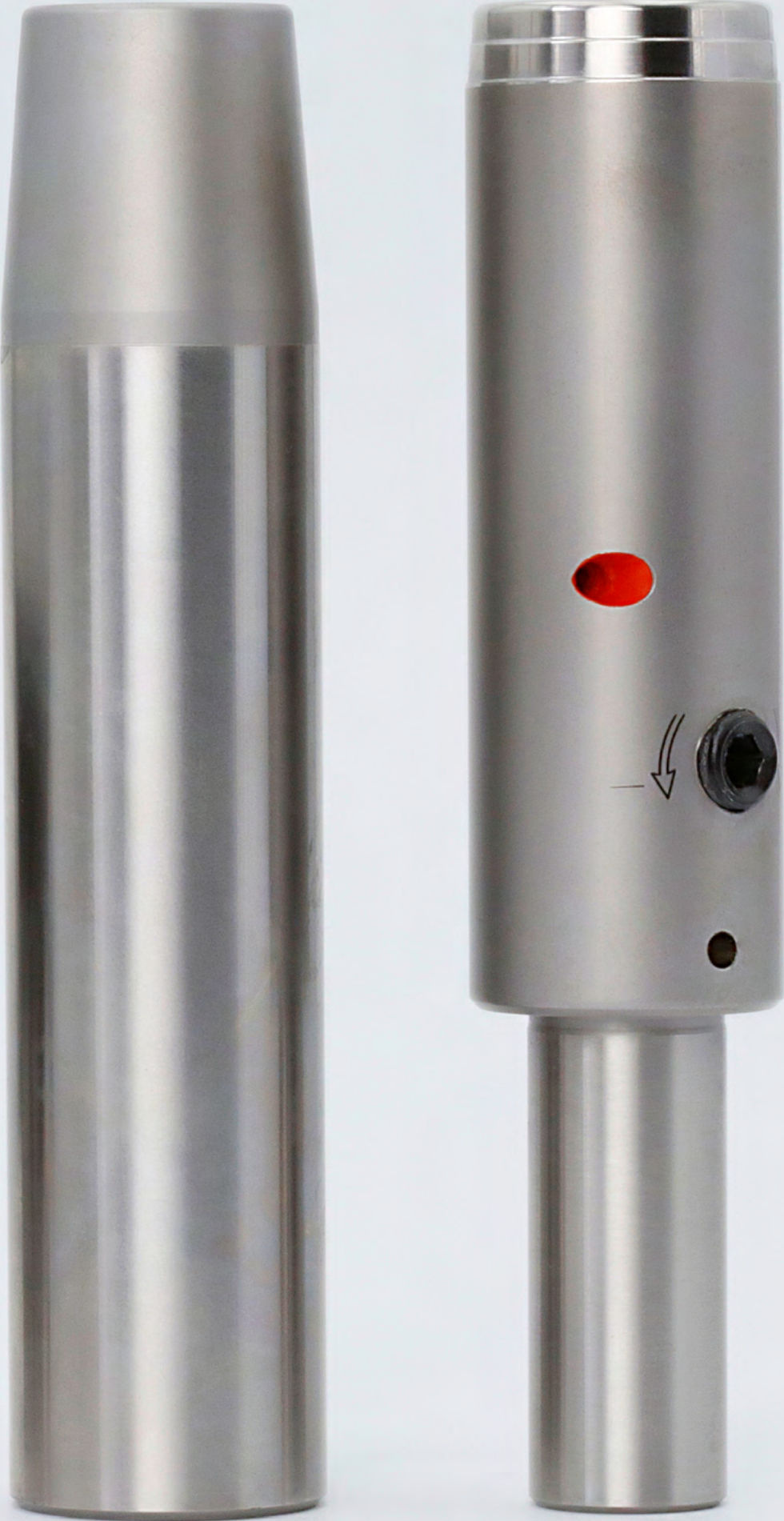

ACCESSORIES AND SPARE PARTS







ACCESSORIES AND SPARE PARTS

Accessories and spare parts

Coolant tubes, locking screw	136
Reducing sleeve, coolant sealed	137
Reducing sleeve, KKB	139
Length adjustment screw, direct clamping	140
Actuation screws	140
AAS adjustment screws	141
Assembly tool	142
Code carrier	144
Test pins for hydraulic chucks	144
Spare parts for WTE drill chucks	145



Coolant tubes, locking screw

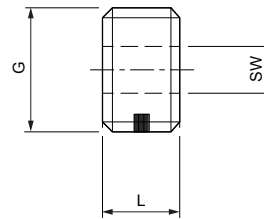
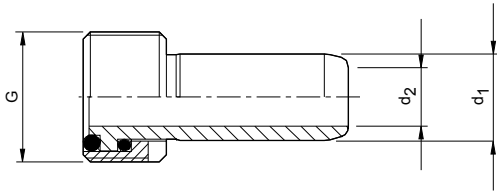

Coolant tubes according to DIN 69895

HSK	Dimensions			Order no.
	G	d ₁	d ₂	
32	M10x1	6,0	3,5	30326003
40	M12x1	8,0	5,0	30326004
50	M16x1	10,0	6,4	30326005
63	M18x1	12,0	8,0	30326006
80	M20x1,5	14,0	10,0	30326007
100	M24x1,5	16,0	12,0	30326008

Locking screws

HSK	Dimensions			Order no.
	G	L	SW	
32	M10x1	5,5	4	30326075
40	M12x1	7,5	5	30326076
50	M16x1	9,5	6	30326077
63	M18x1	11,5	8	30326078
80	M20x1,5	13,5	10	30326079
100	M24x1,5	15,5	12	30326074

Reducing sleeve, coolant sealed

Slotted, for flexible diameter application

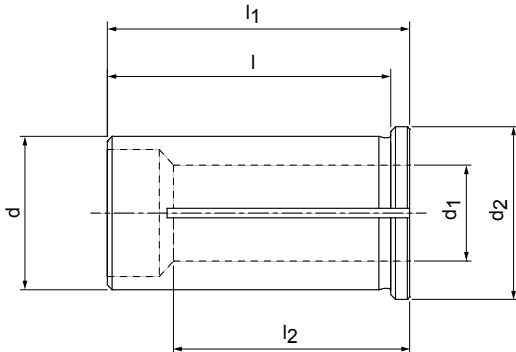

Dimensions							Order designation	Order no.
d	d ₁	d ₂	l	l ₁	l ₂	Weight [kg]		
12,0	1,0	16,0	40,0	44,0	20,0	0,04	40.456.12.01.Z	30503691
12,0	1,5	16,0	40,0	44,0	20,0	0,04	40.456.12.015.Z	30503718
12,0	2,0	16,0	40,0	44,0	20,0	0,04	40.456.12.02.Z	30503725
12,0	2,5	16,0	40,0	44,0	20,0	0,04	40.456.12.025.Z	30503728
12,0	3,0	16,0	40,0	44,0	29,0	0,03	40.456.12.03.Z	30251059
12,0	4,0	16,0	40,0	44,0	29,0	0,03	40.456.12.04.Z	30251060
12,0	5,0	16,0	40,0	44,0	29,0	0,03	40.456.12.05.Z	30251061
12,0	6,0	16,0	40,0	44,0	36,0	0,03	40.456.12.06.Z	30251062
12,0	7,0	16,0	40,0	44,0	37,0	0,03	40.456.12.07.Z	30251063
12,0	8,0	16,0	40,0	44,0	37,0	0,02	40.456.12.08.Z	30251064
12,0	9,0	16,0	40,0	44,0	37,0	0,02	40.456.12.09.Z	30251065
12,0	10,0	16,0	40,0	44,0	40,0	0,01	40.456.12.10.Z	30251066
20,0	3,0	25,0	50,0	54,0	28,0	0,1	40.456.20.03.Z	30251067
20,0	4,0	25,0	50,0	54,0	28,0	0,1	40.456.20.04.Z	30251068
20,0	5,0	25,0	50,0	54,0	28,0	0,1	40.456.20.05.Z	30251069
20,0	6,0	25,0	50,0	54,0	36,0	0,1	40.456.20.06.Z	30251070
20,0	7,0	25,0	50,0	54,0	38,0	0,1	40.456.20.07.Z	30251071
20,0	8,0	25,0	50,0	54,0	37,0	0,09	40.456.20.08.Z	30251072
20,0	9,0	25,0	50,0	54,0	38,0	0,09	40.456.20.09.Z	30251073
20,0	10,0	25,0	50,0	54,0	40,0	0,09	40.456.20.10.Z	30251074
20,0	11,0	25,0	50,0	54,0	40,0	0,08	40.456.20.11.Z	30251075
20,0	12,0	25,0	50,0	54,0	45,0	0,08	40.456.20.12.Z	30251076
20,0	13,0	25,0	50,0	54,0	45,0	0,07	40.456.20.13.Z	30251077
20,0	14,0	25,0	50,0	54,0	45,0	0,07	40.456.20.14.Z	30251078
20,0	15,0	25,0	50,0	54,0	45,0	0,06	40.456.20.15.Z	30251079
20,0	16,0	25,0	50,0	54,0	48,0	0,05	40.456.20.16.Z	30251080

Attention: Never attempt clamping without a tool – the reducing sleeve will be damaged!

Reducing sleeve, coolant sealed

Slotted, for flexible diameter application

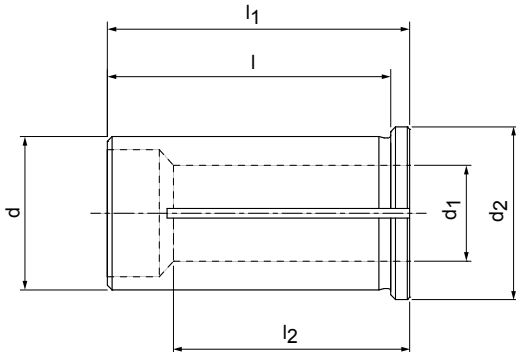

Dimensions							Order designation	Order no.
d	d ₁	d ₂	l	l ₁	l ₂	Weight [kg]		
25,0	3,0	30,0	56,0	60,0	29,0	0,18	40.456.25.03.Z	30251081
25,0	4,0	30,0	56,0	60,0	29,0	0,18	40.456.25.04.Z	30251082
25,0	5,0	30,0	56,0	60,0	29,0	0,18	40.456.25.05.Z	30251083
25,0	6,0	30,0	56,0	60,0	37,0	0,18	40.456.25.06.Z	30251084
25,0	7,0	30,0	56,0	60,0	37,0	0,18	40.456.25.07.Z	30251085
25,0	8,0	30,0	56,0	60,0	37,0	0,17	40.456.25.08.Z	30251086
25,0	9,0	30,0	56,0	60,0	38,0	0,17	40.456.25.09.Z	30251087
25,0	10,0	30,0	56,0	60,0	40,0	0,16	40.456.25.10.Z	30251088
25,0	12,0	30,0	56,0	60,0	46,0	0,15	40.456.25.12.Z	30251089
25,0	14,0	30,0	56,0	60,0	47,0	0,14	40.456.25.14.Z	30251090
25,0	16,0	30,0	56,0	60,0	48,0	0,13	40.456.25.16.Z	30251091
25,0	18,0	30,0	56,0	60,0	48,0	0,11	40.456.25.18.Z	30251092
25,0	20,0	30,0	56,0	60,0	50,0	0,09	40.456.25.20.Z	30251093
32,0	6,0	36,0	60,0	64,0	36,0	0,31	40.456.32.06.Z	30251094
32,0	7,0	36,0	60,0	64,0	37,0	0,31	40.456.32.07.Z	30251095
32,0	8,0	36,0	60,0	64,0	36,0	0,30	40.456.32.08.Z	30251096
32,0	9,0	36,0	60,0	64,0	37,0	0,30	40.456.32.09.Z	30251097
32,0	10,0	36,0	60,0	64,0	40,0	0,29	40.456.32.10.Z	30251098
32,0	11,0	36,0	60,0	64,0	40,0	0,28	40.456.32.11.Z	30251099
32,0	12,0	36,0	60,0	64,0	45,0	0,28	40.456.32.12.Z	30251100
32,0	13,0	36,0	60,0	64,0	45,0	0,28	40.456.32.13.Z	30251101
32,0	14,0	36,0	60,0	64,0	46,0	0,27	40.456.32.14.Z	30251102
32,0	15,0	36,0	60,0	64,0	46,0	0,26	40.456.32.15.Z	30251103
32,0	16,0	36,0	60,0	64,0	48,0	0,26	40.456.32.16.Z	30251104
32,0	17,0	36,0	60,0	64,0	48,0	0,25	40.456.32.17.Z	30251105
32,0	18,0	36,0	60,0	64,0	49,0	0,24	40.456.32.18.Z	30251106
32,0	19,0	36,0	60,0	64,0	49,0	0,23	40.456.32.19.Z	30251107
32,0	20,0	36,0	60,0	64,0	50,0	0,22	40.456.32.20.Z	30251108
32,0	22,0	36,0	60,0	64,0	50,0	0,19	40.456.32.22.Z	30251109
32,0	25,0	36,0	60,0	64,0	56,0	0,15	40.456.32.25.Z	30251110

Attention: Never attempt clamping without a tool – the reducing sleeve will be damaged!

Reducing sleeve, KKB

With cooling channel bore, for flexible diameter application

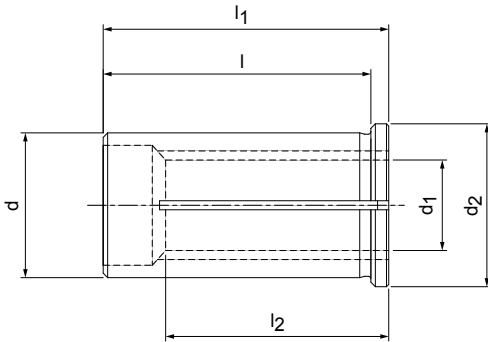

Dimensions							Order designation	Order no.
d	d ₁	d ₂	l	l ₁	l ₂	Weight [kg]		
12,0	3,0	16,0	40,0	44,0	29,0	0,03	40.456.12.03.KKB	30557343
12,0	4,0	16,0	40,0	44,0	29,0	0,03	40.456.12.04.KKB	30557344
12,0	5,0	16,0	40,0	44,0	29,0	0,03	40.456.12.05.KKB	30557345
12,0	6,0	16,0	40,0	44,0	36,0	0,03	40.456.12.06.KKB	30557346
12,0	8,0	16,0	40,0	44,0	37,0	0,02	40.456.12.08.KKB	30557347
20,0	3,0	25,0	50,0	54,0	28,0	0,10	40.456.20.03.KKB	30557348
20,0	4,0	25,0	50,0	54,0	28,0	0,10	40.456.20.04.KKB	30557350
20,0	5,0	25,0	50,0	54,0	28,0	0,10	40.456.20.05.KKB	30557351
20,0	6,0	25,0	50,0	54,0	36,0	0,10	40.456.20.06.KKB	30557352
20,0	8,0	25,0	50,0	54,0	37,0	0,09	40.456.20.08.KKB	30557353
20,0	10,0	25,0	50,0	54,0	40,0	0,09	40.456.20.10.KKB	30557354
20,0	12,0	25,0	50,0	54,0	45,0	0,08	40.456.20.12.KKB	30557355
20,0	14,0	25,0	50,0	54,0	45,0	0,07	40.456.20.14.KKB	30557356
20,0	16,0	25,0	50,0	54,0	48,0	0,05	40.456.20.16.KKB	30557358
32,0	6,0	36,0	60,0	64,0	36,0	0,31	40.456.32.06.KKB	30557359
32,0	8,0	36,0	60,0	64,0	36,0	0,30	40.456.32.08.KKB	30557360
32,0	10,0	36,0	60,0	64,0	40,0	0,29	40.456.32.10.KKB	30557361
32,0	12,0	36,0	60,0	64,0	45,0	0,28	40.456.32.12.KKB	30557362
32,0	14,0	36,0	60,0	64,0	46,0	0,27	40.456.32.14.KKB	30557364
32,0	16,0	36,0	60,0	64,0	48,0	0,26	40.456.32.16.KKB	30557365
32,0	18,0	36,0	60,0	64,0	49,0	0,24	40.456.32.18.KKB	30557366
32,0	20,0	36,0	60,0	64,0	50,0	0,22	40.456.32.20.KKB	30557367
32,0	25,0	36,0	60,0	64,0	56,0	0,15	40.456.32.25.KKB	30557369

Attention: Never attempt clamping without a tool – the reducing sleeve will be damaged!

Length adjustment screw direct clamping

For axial length adjustment

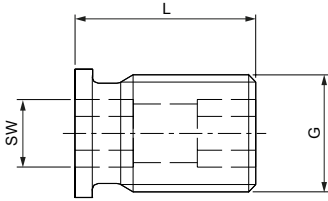

G	SW	L	Weight [kg]	Order no.
M5	2	14,0	0,001	30336661
M5	2,5	12,5	0,001	30252539
M6	2	14,0	0,002	30252537
M6	3	12,5	0,002	30252540
M8x1	3	13,5	0,004	30252541
M10x1	5	13,5	0,006	30252542
M12x1	5	13,5	0,011	30252543
M16x1	5	13,5	0,017	30252544
M16x1	8	13,5	0,021	30252547

Actuation screw for hydraulic chucks

For application of pressure

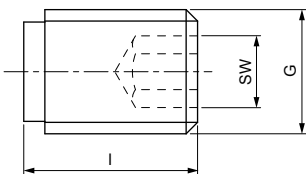

G	SW	L	Weight [kg]	Order no.
M10	5	10,0	0,006	10003470
M10	5	14,0	0,009	10070217

AAS adjustment screws

When using WTE reducing sleeves for axial length adjustment

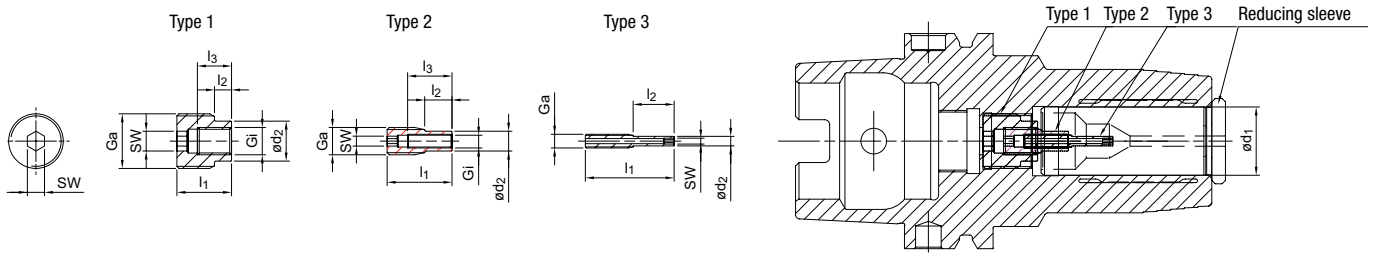

AAS 12 for Art. No. 40.456.12.xx

Ga	Gi	ø d ₁	ø d ₂	l ₁	l ₂	l ₃	SW	Type	Order designation	Order no.
M10x1	M4x0,5	12,0	5,8	22,0	13,0	16,0	2,5	1	89.122.103	30308896
M4x0,5	-	12,0	2,8	26,0	12,0	-	1,5	3	89.122.101	30308901

AAS 20 for Art. No. 40.456.20.xx

M16x1	M8x1	20,0	11,7	16,0	5,0	10,0	5	1	89.122.99	30308897
M8x1	M4x0,5	20,0	5,8	19,0	8,0	13,0	2,5	2	89.122.100	30308899
M4x0,5	-	20,0	2,8	26,0	12,0	-	1,5	3	89.122.101	30308901

AAS 25 for Art. No. 40.456.25.xx

M16x1	M8x1	25,0	11,7	24,0	11,0	10,0	5	1	89.122.104	30308904
M8x1	M4x0,5	25,0	5,8	19,0	8,0	13,0	2,5	2	89.122.100	30308899
M4x0,5	-	25,0	2,8	26,0	12,0	-	1,5	3	89.122.101	30308901

AAS 32 for Art. No. 40.456.32.xx

M16x1	M8x1	32,0	11,7	24,0	11,0	10,0	5	1	89.122.104	30308904
M8x1	M4x0,5	32,0	5,8	19,0	8,0	13,0	2,5	2	89.122.100	30308899

Dimensions in mm.

Note: For usage with reducing sleeves for hydraulic chucks.

Assembly tool

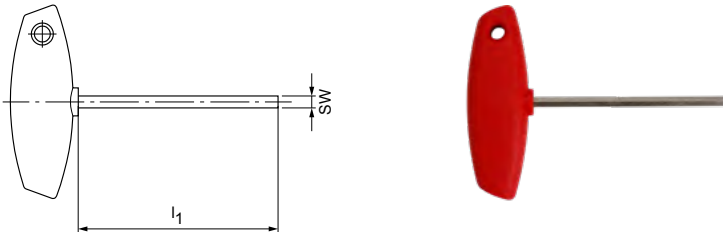

Hexagonal T-key

SW	Short design			Long design	
	l ₁	Order designation	Order no.	l ₁	Order no.
2	100,0	–	10006942	200	10034235
2,5	100,0	–	10006233	200	10032722
3	100,0	MN5221-31	10006234	200	10025313
4	100,0	MN5221-32	10006235	200	10018010
5	100,0	MN5221-33	10006236	200	10013350
6	100,0	MN5221-34	10006237	–	–
8	100,0	MN5221-35	10006238	–	–
10	100,0	–	30353270	–	–

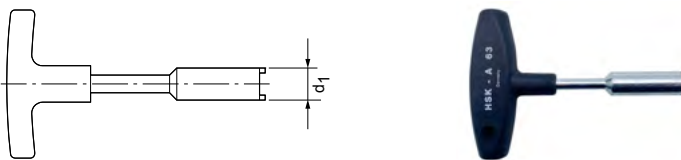

Assembly tools for fitting and removing coolant tubes or adapter tubes on the KS MQL clamping cartridges

HSK	d ₁	For coolant tube according to DIN 69895		For blanking plugs/adapter tube on the KS clamping cartridges for MQL applications	
		Order designation	Order no.	Order designation	Order no.
32	9,0	MAT-HSK-A032-1	10074750	MAT-KS032-040-G	10079521
40	11,0	MAT-HSK-A040-1	10074751	MAT-KS032-040-G	10079521
50	15,0	MAT-HSK-A050-1	10074752	MAT-KS050-063-G	10079522
63	17,0	MAT-HSK-A063-1	10040110	MAT-KS050-063-G	10079522
80	18,0	MAT-HSK-A080-1	10074774	MAT-KS080-G	10079523
100	22,0	MAT-HSK-A100-1	10074775	MAT-KS100-G	10079525

Assembly tool

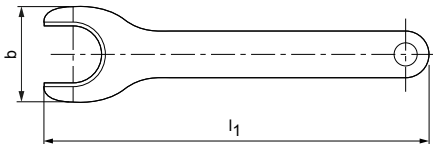

Extraction wrench for simple removal of the reducing sleeves from the WTE hydraulic chucks

Nominal size	Dimensions		Order designation	Order no.
	b	l ₁		
HS12	24,6	100,0	MN5425-99	30251198
HS20	38	160,0	MN5427-99	30251199
HS25	51	180,0	MN5428-99	30251200
HS32	63	200,0	MN5429-99	30251201

Code carrier

According to DIN 69873-D10



Name	Manufacturer	Storage capacity	Dimensions		Order no.
			d_1	l_1	
BIS C-122-04/L	Balluff	511 Byte	10,0	4,5	10004178
BIS M-122-01/A	Balluff	752 Byte	10,0	4,5	30433956
BIS C-122-11/L	Balluff	2000 Byte	10,0	4,5	30532418
BIS M-122-02/A	Balluff	1000 Byte	10,0	4,5	30546468
BIS C-122-05/L	Balluff	752 Byte	10,0	4,5	30854698
MDS E623	Siemens	2047 Byte	10,0	4,5	10058310
MDS D421	Siemens	2000 Byte	10,0	4,5	30415066
V680-D1KP53M	Boie	1023 Byte	10,0	4,5	30430859

Test pins for hydraulic chuck

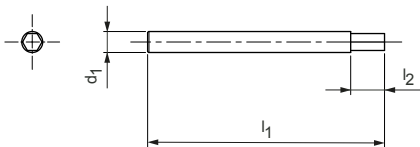

Test pin with hexagonal head

d_1	l_1	l_2	Order designation	Order no.
3.0	70.0	20.0	Test arbor minimum torque with hexagonal head	31212889
4.0	70.0	20.0	Test arbor minimum torque with hexagonal head	31212892
5.0	70.0	20.0	Test arbor minimum torque with hexagonal head	31212893
6.0	70.0	10.0	Test arbor minimum torque with hexagonal head	30844163
8.0	70.0	10.0	Test arbor minimum torque with hexagonal head	30844164
10.0	70.0	10.0	Test arbor minimum torque with hexagonal head	30844166
12.0	70.0	15.0	Test arbor minimum torque with hexagonal head	30844167
14.0	70.0	15.0	Test arbor minimum torque with hexagonal head	30844168
16.0	70.0	15.0	Test arbor minimum torque with hexagonal head	30844170
18.0	70.0	15.0	Test arbor minimum torque with hexagonal head	30844171
20.0	70.0	20.0	Test arbor minimum torque with hexagonal head	30844173
25.0	100.0	20.0	Test arbor minimum torque with hexagonal head	30844174
32.0	100.0	20.0	Test arbor minimum torque with hexagonal head	30844175

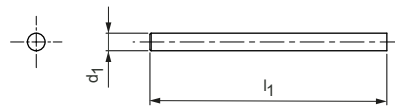

Test pin without hexagonal head

d_1	l_1	Order designation	Order no.
3.0	70.0	Test arbor minimum revolutions cylindrical	31212898
4.0	70.0	Test arbor minimum revolutions cylindrical	31212910
5.0	70.0	Test arbor minimum revolutions cylindrical	31212911
6.0	70.0	Test arbor minimum revolutions cylindrical	30985677
8.0	70.0	Test arbor minimum revolutions cylindrical	30985678
10.0	70.0	Test arbor minimum revolutions cylindrical	30985679
12.0	70.0	Test arbor minimum revolutions cylindrical	30985690
14.0	70.0	Test arbor minimum revolutions cylindrical	30985691
16.0	70.0	Test arbor minimum revolutions cylindrical	30985693
18.0	70.0	Test arbor minimum revolutions cylindrical	30985694
20.0	70.0	Test arbor minimum revolutions cylindrical	30985696
25.0	100.0	Test arbor minimum revolutions cylindrical	30985697
32.0	100.0	Test arbor minimum revolutions cylindrical	30985698

Spare parts for WTE drill chuck



Spare parts for precision drill chuck

Description	Order designation	Order no.
Ritzel-Schraubendreher 08	89.208.24	30266182
Ritzel-Schraubendreher 13 / 16	89.213.21	30266183
Ritzelschraube 08	89.208.08	30266192
Ritzelschraube 13 und 16	89.213.08	30266193
Ritzel 08	89.208.36	30903379
Ritzel 13	89.213.05	30266142
Ritzel 16	89.216.05	30266143

Spare parts for standard drill chuck

Description	Order designation	Order no.
Ritzel Schraubendreher 13 / 16	89.213.21	30266183
Ritzel 13/16	89.213.102	30336464
Ritzelschraube 13 / 16	89.213.08	30266193

Hexagonal T-key

For pinion operation

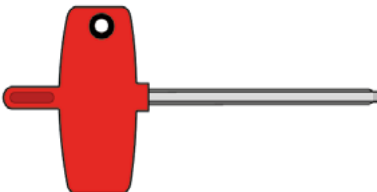

SW	l	Weight [kg]	WTE standard	Order designation	Order no.
2	60,0	0,01	WTE 03	89.206.08	30435838
2,5	60,0	0,01	WTE 06	89.206.10	10098110



TECHNICAL APPENDIX

Notes on standards, application and handling



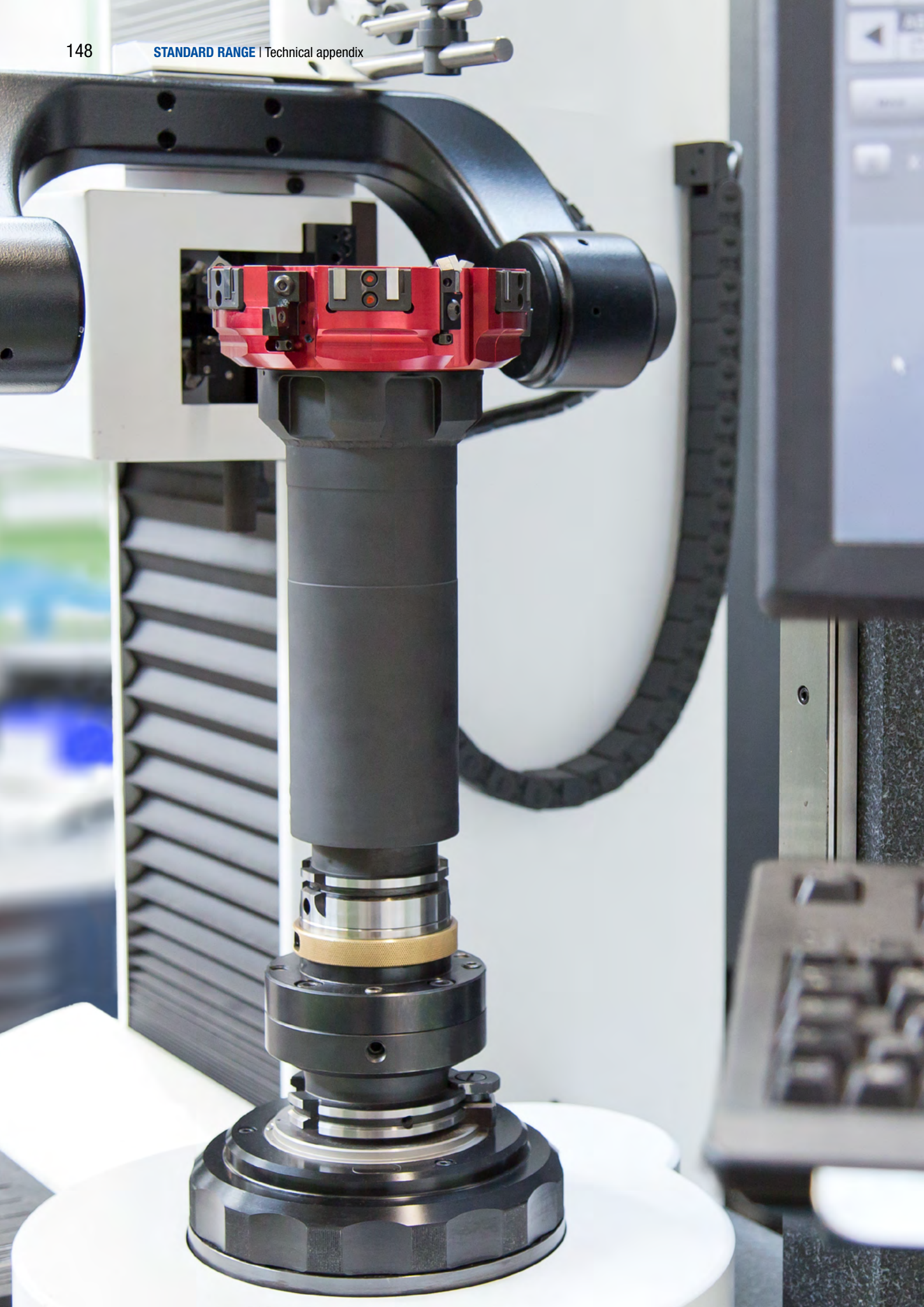

TECHNICAL APPENDIX

Important technical notes and background information on WTE clamping technology are given in the following. In addition to the standards of HSK-A, HSK-E and HSK-F, the different SK variants are also documented. Subsequently, there are important technical notes on the individual chucks covered in the catalogue.

The torques that can be transferred, radial run-out accuracy and accuracy of repeatability as well as the spindle speed limits for the various connections are also explained.

General technical information

Standards and fitting dimensions	150
----------------------------------	-----

Application notes

Hydraulic clamping technology	160
Shrinking technology	164
Precision drilling technology	165

Handling notes

Hydraulic clamping technology	166
Side lock chuck MillChuck, System HB	168
Milling cutter arbor with vibration dampening	170

Hollow shank taper standard

For hollow shanks DIN 69893-1 HSK-A, HSK-C

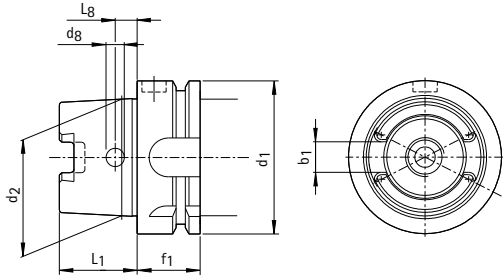

HSK-A for automatic and manual tool change

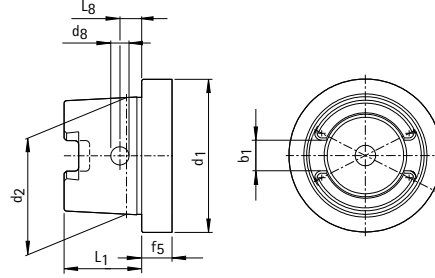

HSK-C for manual tool change

		Hollow shank taper size					
Nominal size	d_1 h10	32	40	50	63	80	100
Taper diameter	d_2	24,007	30,007	38,009	48,01	60,012	75,013
Shank length	L_1 0/-0,2	16	20	25	32	40	50
Groove width	b_1 +/-0,04	7,05	8,05	10,54	12,54	16,04	20,02
Bore diameter	d_8	4	4,6	6	7,5	8,5	12
Bore spacing	L_8 +/-0,1	5	6	7,5	9	12	15
Flange width hollow shank taper A	f_1 0/-0,1	20	20	26	26	26	29
Flange width hollow shank taper C	f_5	10	10	12,5	12,5	16	16

Hollow shank taper standard

For connections DIN 69093-1 HSK-A, HSK-C

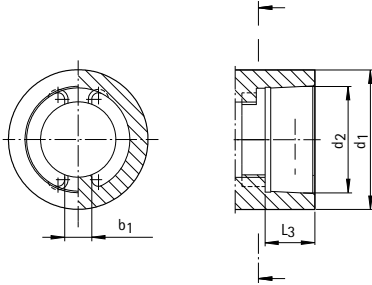

HSK-A for automatic tool change

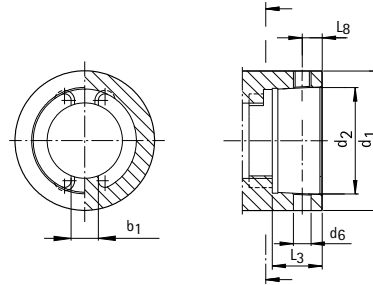

HSK-C for manual tool change

		Hollow shank taper size					
Nominal size	d_1	32	40	50	63	80	100
Taper diameter	d_2	23,998	29,998	37,998	47,998	59,997	74,997
Depth	$L_3 +0,2$	11,4	14,4	17,9	22,4	28,4	35,4
Driving element width	$b_1 \pm 0,05$	6,8	7,8	10,3	12,3	15,8	19,78
Additional for HSK-C							
Bore diameter	d_6	4	5	6	8	9	11
Bore spacing	$L_8 \pm 0,1$	5	6	7,5	9	12	15

Hollow shank taper standard

For hollow shanks DIN 69893-5, HSK-E and DIN 69893-6, HSK-F

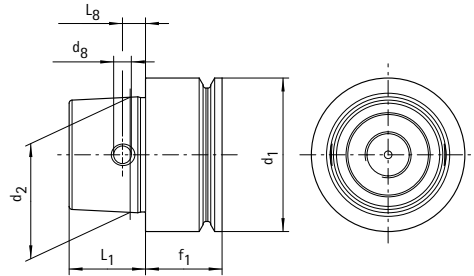
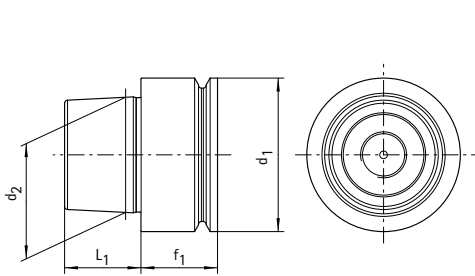

Hollow shank taper form E (HSK-E) for automatic tool change

Hollow shank taper form E (HSK-E) for automatic and manual tool change

		Hollow shank taper size				
Nominal size	d_1 h10	25	32	40	50	63
Taper diameter	d_2	19,006	24,007	30,007	38,009	48,01
Shank length	L_1 0/-0,2	13	16	20	25	32
Bore diameter	d_8	3,7	4	4,6	6	7,5
Bore spacing	L_8 +/-0,1	4	5	6	7,5	9
Flange width hollow shank taper E	f_1 0/-0,1	10	20	20	26	26

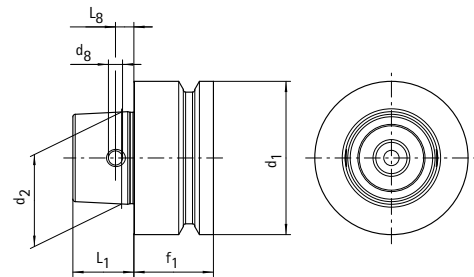
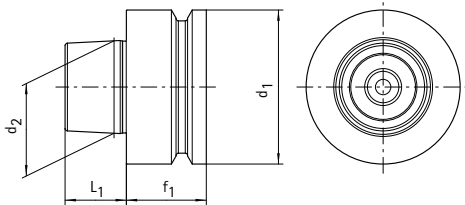

HSK-F for automatic tool change

HSK-F for automatic and manual tool change

		Hollow shank taper size				
Nominal size	d_1 h10	50	63	80		
Taper diameter	d_2	30,007	38,009	48,01		
Shank length	L_1 0/-0,2	20	25	32		
Bore diameter	d_8	4,6	6	7,5		
Bore spacing	L_8 +/-0,1	6	7,5	9		
Flange width hollow shank taper F	f_1 0/-0,1	26	26	26		

Hollow shank taper standard

For connections, DIN 69893-5, HSK-E

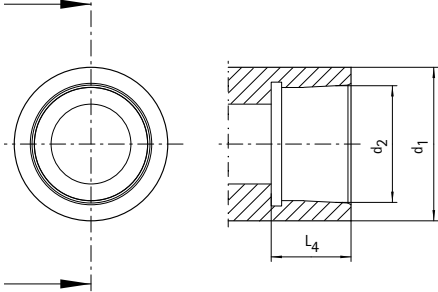

Hollow shank taper form E (HSK-E) for automatic tool change

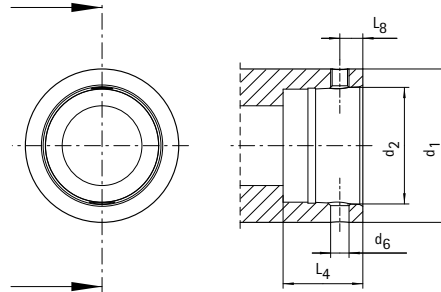

Hollow shank taper form E (HSK-E) for manual tool change

		Hollow shank taper size			
Nominal size	d_1	32	40	50	63
Taper diameter	d_2	23,998	29,998	37,998	47,998
Depth	$L_4 +0,2$	16,5	20,5	25,5	33
Bore diameter	d_6	4,5	5	6	8
Bore spacing	$L_8 \pm 0,1$	5	6	7,5	9

Dimensions in mm.

Scope of delivery: Stop ring, without holding screw.

Coding system for hollow taper shanks

Multiple spindle drill heads are often used in custom machines. In this case a large number of spindles are arranged in a small space. So that operating errors can be excluded during the tool change, the DIN 69894 coding system for hollow taper shanks has been developed.

Additional pins in the tool spindles and slots on the end of the HSK shank ensure unambiguous allocation of a tool to a specific spindle.

Coding system for tool spindles:

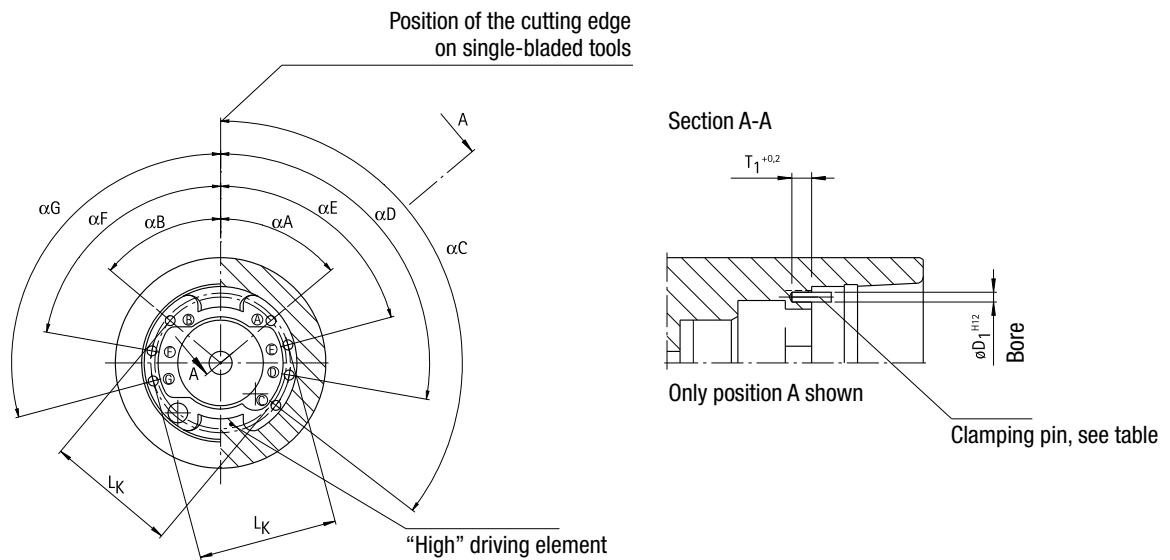

Position HSK	Ⓐ α A	Ⓑ α B	Ⓒ α C	Ⓓ α D	Ⓔ α E	Ⓕ α F	Ⓖ α G	D ₁	T ₁	L _K	Clamping pin
32	50°	50°	127,5°	100°	75°	80°	105°	1,5	3		ISO 8752-1,5x6
40	52,5°	52,5°	127,5°	100°	75°	80°	105°	2	3		ISO 8752-2x6
50	55°	55°	125°	100°	75°	80°	105°	2,5	3		ISO 8752-2,5x6
63	60°	60°	120°	105°	75°	75°	105°	3,5	4		ISO 8752-3,5x8
80	60°	60°	120°	105°	75°	75°	105°	4,5	5		ISO 8752-4,5x10
100	45°	45°	135°	105°	75°	75°	105°	4,5	7		ISO 8752-4,5x12
125	45°	45°	135°	105°	75°	75°	105°	4,5	7		ISO 8752-4,5x12
160	45°	45°	135°	105°	75°	75°	105°	4,5	7		ISO 8752-4,5x12

■ = preferable

Coding system for hollow taper shanks

Coding system for tool shanks:

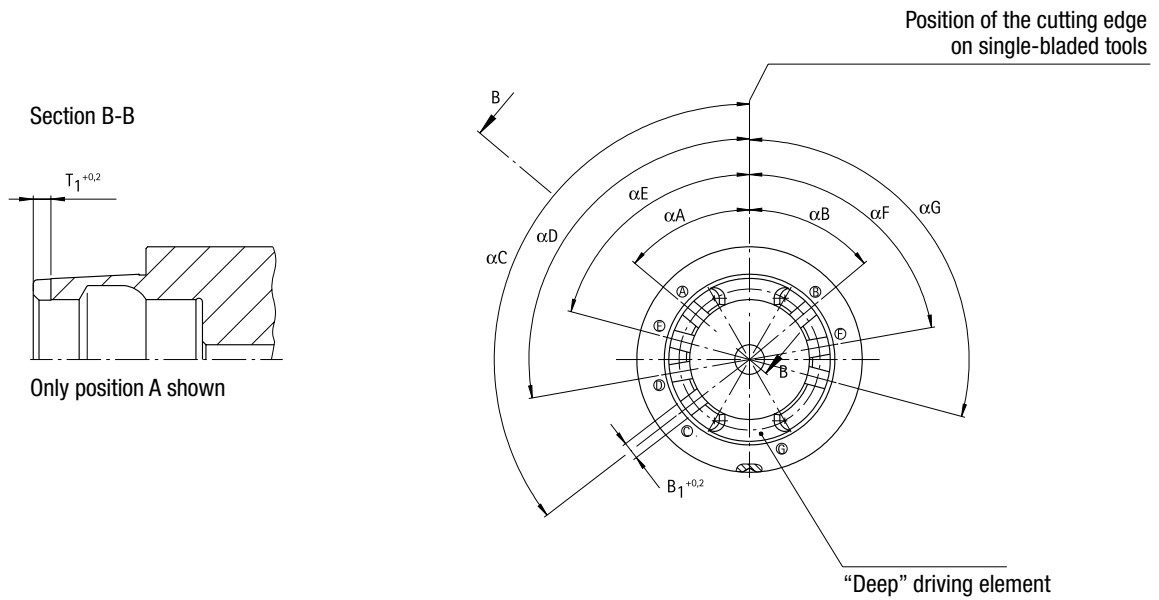

Position HSK	Ⓐ α A	Ⓑ α B	Ⓒ α C	Ⓓ α D	Ⓔ α E	Ⓕ α F	Ⓖ α G	B ₁	T ₁
32	50°	50°	127,5°	100°	75°	80°	105°	2,5	2,5
40	52,5°	52,5°	127,5°	100°	75°	80°	105°	3	2,5
50	55°	55°	125°	100°	75°	80°	105°	3,5	2,5
63	60°	60°	120°	105°	75°	75°	105°	4,5	3,5
80	60°	60°	120°	105°	75°	75°	105°	5,5	4,5
100	45°	45°	135°	105°	75°	75°	105°	5,5	5
125	45°	45°	135°	105°	75°	75°	105°	5,5	5
160	45°	45°	135°	105°	75°	75°	105°	5,5	5

■ = preferable

SK Standard

For steep taper tool shanks according to ISO 7388-1

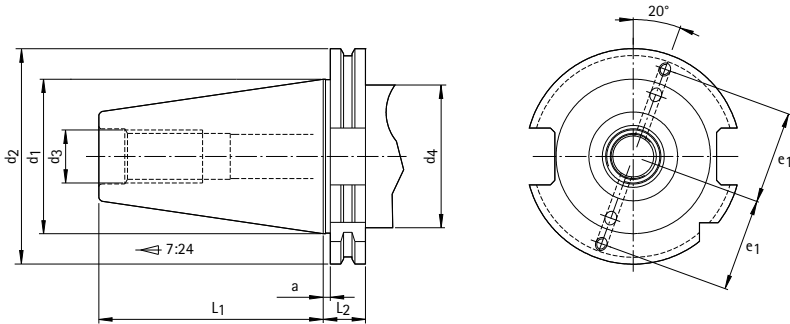

For automatic tool change Form A, Form AD, Form AF and design with data carrier

	Size			
	30	40	45	50
a +/-0,1	3,2	3,2	3,2	3,2
d ₁	31,75	44,45	57,15	69,85
d ₂ 0/-0,1	50	63,55	82,55	97,5
d ₃	M 12	M 16	M 20	M 24
d ₄ max.	45	50	63	80
e ₁ +/-0,1	21	27	35	42
L ₁ 0/-0,3	47,8	68,4	82,7	101,75
L ₂ 0/-0,1	19,1	19,1	19,1	19,1

SK Standard

For BT tool shanks according to ISO 7388-2 JIS B 6339

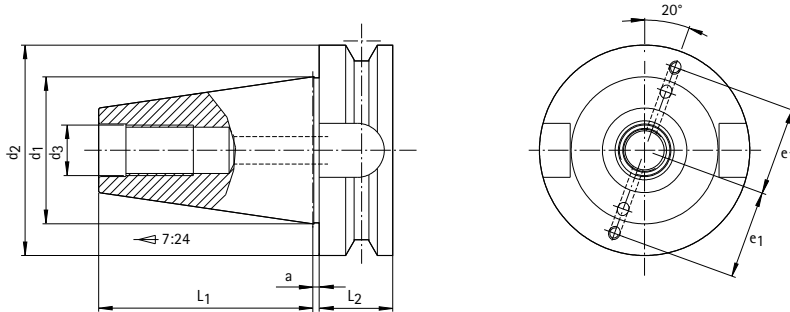

For automatic tool change Form J, Form JF, Form JD and design with data carrier

	Size		
	30	40	50
a $\pm 0,4^*$	2	2	3
d ₁	31,75	44,45	69,85
d ₂ h8	46	63	100
d ₃	M 12	M 16	M 24
e ₁ $\pm 0,1$	20	27	42
L ₁ $\pm 0,2$	48,4	65,4	101,8
L ₂ min.	22	27	38

* + 0.1 for Form JF

Steep taper standard

For tool shanks according to ASME B5.50-1994

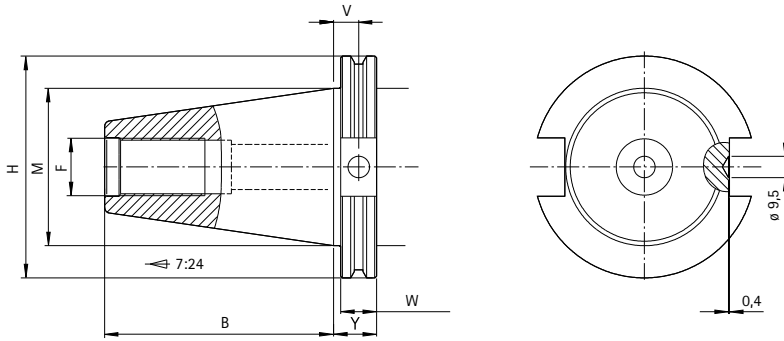

	Taper shank size			
	30	40	45	50
B $\pm 0,1$	47,65	68,25	82,55	101,6
F UNC-2B	1/2"-13	5/8"-11	3/4"-10	1"-8
H $\pm 0,5$	46,02	63,5	82,55	98,43
M $\pm 0,13$	31,75	44,45	57,15	69,85
V $\pm 0,25$	11,2	11,2	11,2	11,2
W $\pm 0,05$	15,88	15,88	15,88	15,88
Y $\pm 0,05$	19,05	19,05	19,05	19,05

Fitting dimensions for KS flanges

Spindle connection contour for flange adapter in accordance with MN5000-14

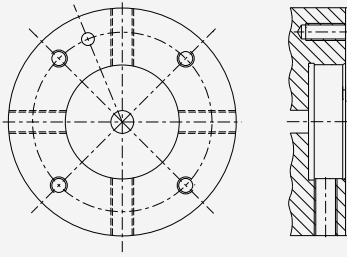

Spindle connection contour for adapter flange according to MN5000-12

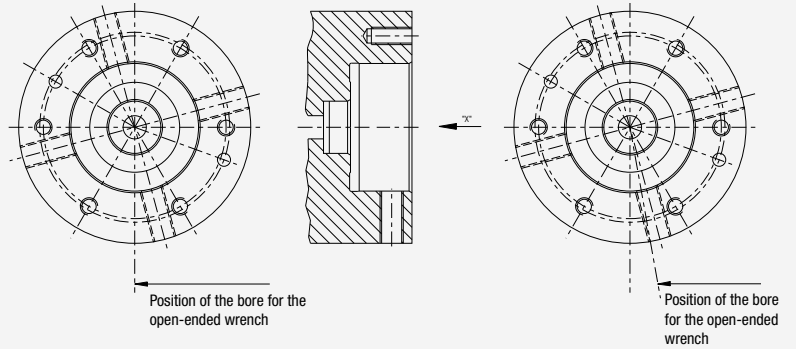

Spindle connection contour for adapter flange for short spindles in accordance with MN5000-13

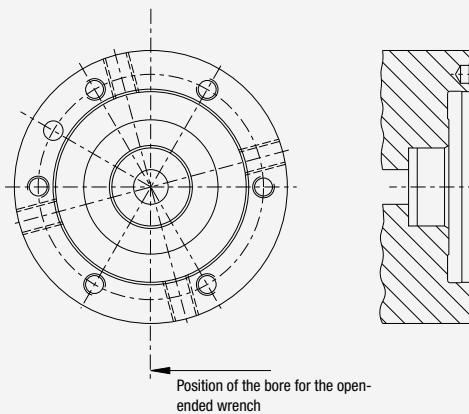

Hydraulic clamping technology

1. Hydraulic clamping technology elements

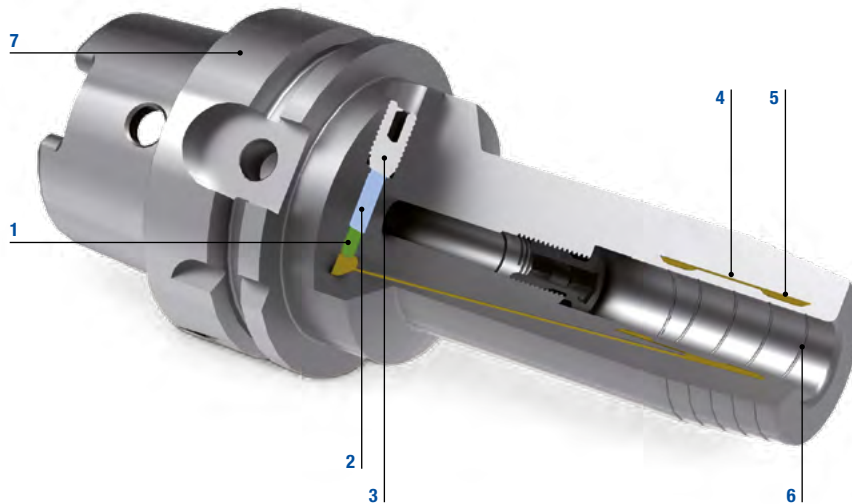

- 1 Sealing element** High levels of leakage at the clamping bore are prevented by the lip seal.
- 2 Piston** Presses the hydraulic medium into the chamber system.
- 3 Clamping screw** Necessary to actuate the piston. Can be actuated without a torque wrench.
- 4 Expanding sleeve** Clamps the tool shank centrally with evenly applied pressure.
- 5 Chamber system** This results from the connection of the expanding sleeve and the tool body. Has a damping effect on the tool thanks to the hydraulic medium and, in this way, reduces wear and tear.
- 6 Groove** Oil, grease or lubricant residues are displaced into the groove by the high clamping pressure. The clamping surfaces remain largely dry and the transmission of the torques is guaranteed.
- 7 Tool body** WTE hydraulic chuck are available for all common machine-side connections (HSK-A, SK, BT and flange module).

When clamping using hydraulic clamping technology, even pressure is built up in a sealed chamber system using a clamping screw and a piston. This pressure is transmitted to the tool via the built-in expanding sleeve.

1. Operating principle

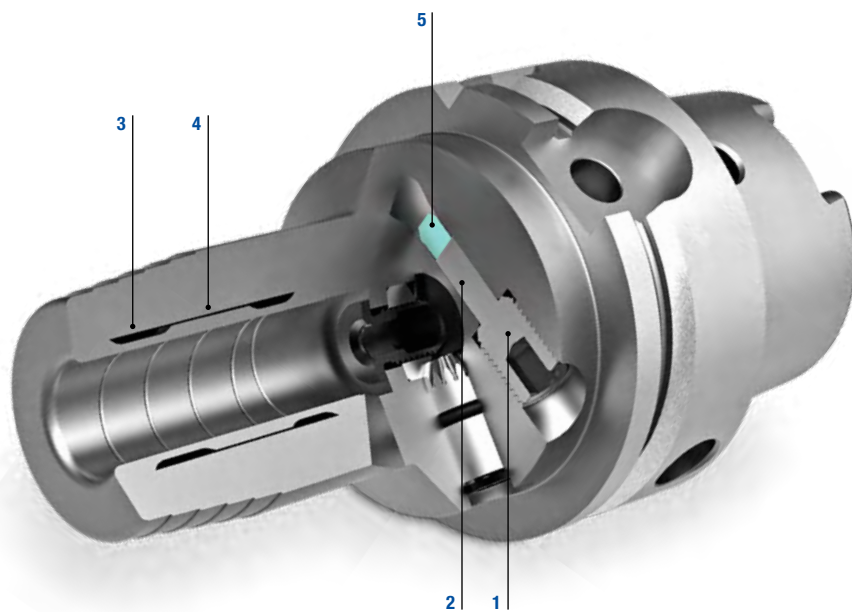

- 1** The **clamping screw** is screwed in with an Allen key until it stops.
- 2** The **piston** presses the hydraulic medium into the **expansion chamber** and causes an increase in pressure.
- 3** The **thin-walled expanding sleeve** curves evenly against the tool shank. The tool shank is centred and then clamped powerfully and uniformly across its entire surface during this clamping process.
- 4** The **sealing element** guarantees absolute tightness and a long tool life.

Technical data

- Workpiece material 1600-1800 N/mm² tensile strength
- Distance adjustment 10 mm
- Hardness 52 + 2 HRC
- DIN 1835 Form A, B, C, D
- Tool holder finely balanced
- DIN 6535 Form HA, HB, HE
- Laser marking
- Coolant pressure maximum 80 bar
- Max. spindle speed 40,000 rpm (pay attention to spindle speed limit connection)
- Optimal operating temperature 20-50 °C; do not use above 80 °C
- Shanks suitable for clamping (tolerance h6) with and without reducing sleeves:
 - DIN 1835 Form A, B, E
 - DIN 6535 Form HA, HB, HE

3. Radial tool length adjustment

WTE offers hydraulic chucks with radial tool length adjustment for clamping tools with hollow shank taper connections. Even with this adjustment method, radial run-out accuracies of $\leq 3 \mu\text{m}$ are guaranteed.

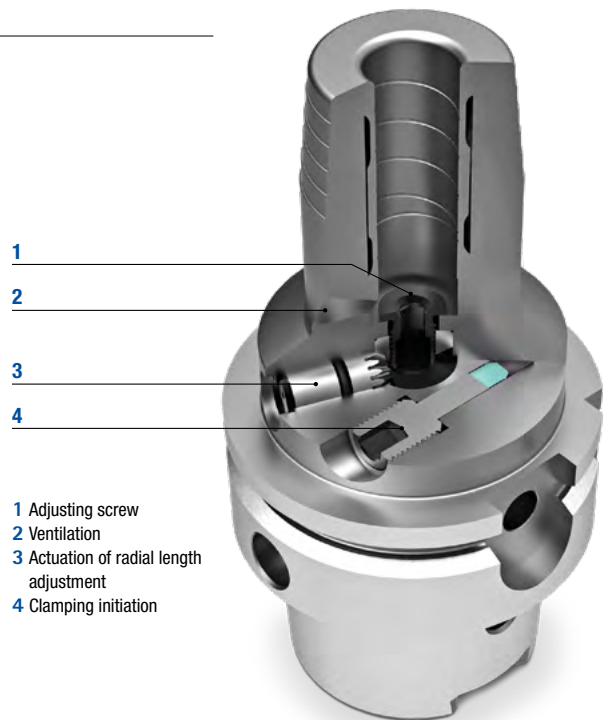

2. Hydraulic clamping technology with compensation technology

The “Compensation” chuck is perfectly suited for light machining tasks with multi-bladed reamers. It builds on hydraulic clamping technology and the radial run-out can be set exactly using three adjustment elements. The radial run-out is corrected straightforwardly and quickly using a hex-wrench depending on the direction of the error. The setting range is down to $15 \mu\text{m}$. Wedges in the chuck align the tool, which prevents jamming. The system is self-locking, which makes unintentional movement during fine machining impossible. A fixed ring seals the alignment system. It is therefore low maintenance and not susceptible to dirt.

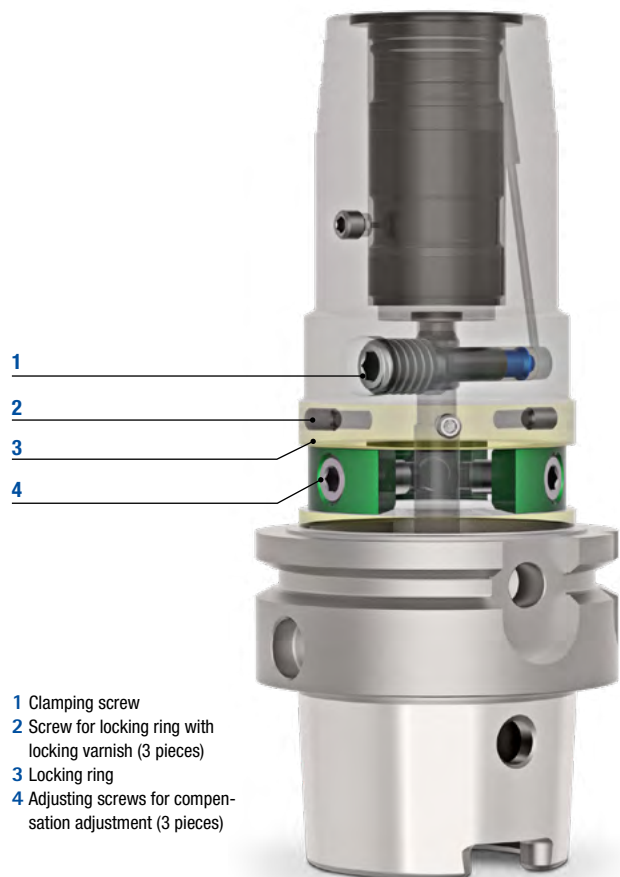

Hydraulic clamping technology

4. Additive-manufactured hydraulic clamping technology

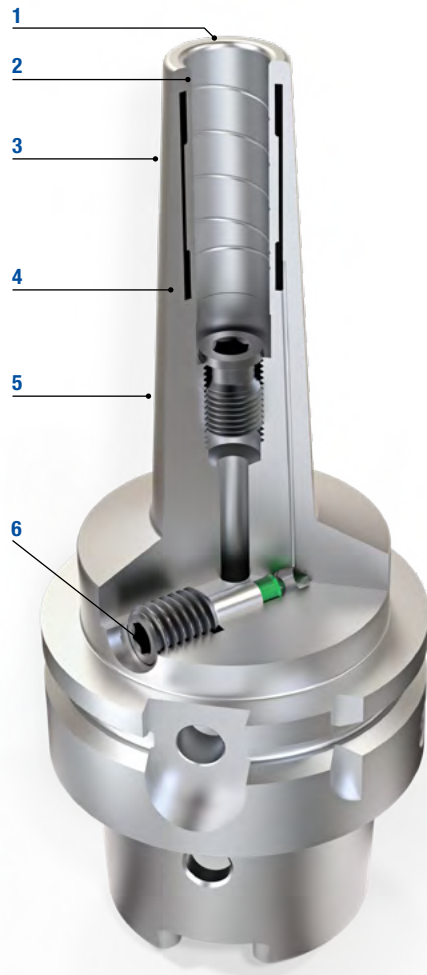

- 1 Optimum radial run-out as the clamping range is positioned close to the chuck tip
- 2 High level of torque transmission and thermal stability
- 3 Back taper of 3° in the outer contour enables machining in the contour-critical area
- 4 Everything from a single cast – no brazed connection between the sleeve and tool body
- 5 High flexural strength despite the slim design
- 6 Simple and fast clamping with a hexagon head screw



5. Torque transmission

HydroChuck

Please use the respective transmittable torque from the table.

The specified torques are valid for cylindrical shanks according to DIN 6535 Form A and DIN 1835.

Transmittable torques with direct clamping, oiled shank, clamping diameter hydraulic chuck $d_1 = 6\text{--}32\text{ mm}$

d_1 [mm]	6	8	10	12	14	16	18	20	25	32
Minimum/maximum size [Nm] for shank h_6	20/30	30/45	47/85	80/140	100/160	160/230	200/270	330/400	400/470	650/730

Transmittable torques measured with reducing sleeve, oiled shank, clamping diameter hydraulic chuck $d_1 = 32\text{ mm}$

d_1 [mm]	6	8	10	12	14	16	18	20	25
Minimum/maximum size [Nm] for shank h_6	30/45	45/65	60/110	120/170	120/170	180/230	220/300	250/320	360/440

Clamping diameter hydraulic chuck $d_1 = 20\text{ mm}$

d_1 [mm]	3	4	5	6	7	8	9	10	11	12
Minimum dimension/maximum dimension [Nm] for shank h_6	6/10	9/12	16/22	30/40		55/75		90/120		120/150

d_1 [mm]	13	14	15	16	17				
Minimum dimension/maximum dimension [Nm] for shank h_6		135/170		190/260					

d_1 [mm]	3	4	5	6	8				
Minimum dimension/maximum dimension [Nm] for shank h_6	3/4	4/8	7/12	12/20	18/26				

HPH

All HPH chucks except 3° slim design at operating temperature: 20–80 °C

Clamping diameter [mm]	Permissible transmittable torque for shank h_6 minimum dimension [Nm]
6	30
8	50
10	100
12	150
14	210
16	280
18	360
20	550
25	650
32	800

3° slim design with operating temperature: 20–120 °C

Clamping diameter [mm]	Permissible transmittable torque for shank h_6 minimum dimension [Nm]
3	3
4	6
5	10
6	20
8	35
10	65
12	110
14	120
16	160
18	200
20	260

Shrinking technology

Shrinking technology uses heat-related material expansion for tool clamping. An induction coil heats the shrink chuck. The chuck expands and the cold tool shank can be inserted. The shrink chuck is cooled down again,

contracts and forms a force-locking connection with the tool due to the oversize of the tool shank.

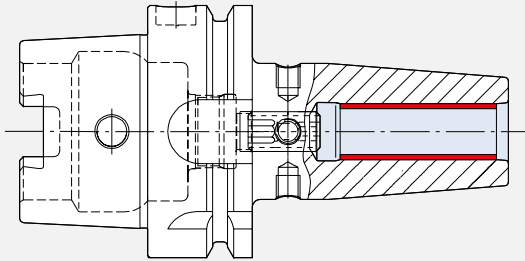

Operating principle

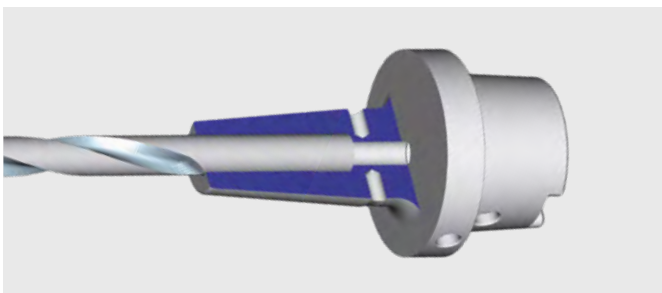
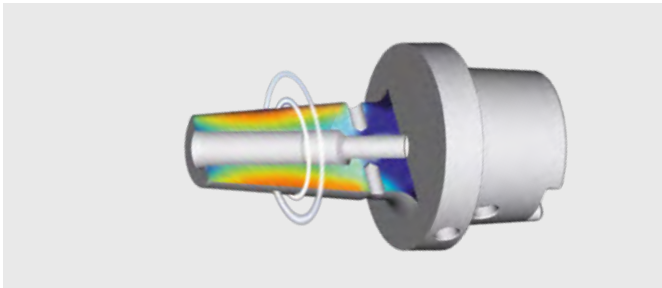

1. Heating up the chuck

The chuck is heated at the clamping point using the latest induction technology. An induction coil generates rapidly changing eddy currents that act directly on the shrink chuck and heat it up exactly where the tool shank is located. The bore diameter increases.

2. Inserting the tool shank

The cold tool shank is inserted into the heated shrink chuck .

3. Cooling down

The shrink chuck is cooled down and the clamping diameter returns to its original dimension and clamps the tool shank. A powerful unit with water-cooled cooling elements enables rapid cooling within 30 seconds. This means that the tapers and data chips do not heat up. Adapters that can be inserted into the heat sink enable the cooling of extensions as well as non-standard shrink chucks.

The result

Due to the inductive heating, tool changes can now be carried out within seconds. The shrink chuck and tool shank form a force-locking connection. Both solid carbide and HSS tools can be clamped. The tool is clamped precisely in the tool adapter with the maximum clamping force.

Precision drill chuck and standard drill chucks



Technical data for precision drill chucks

Clamping range	0,2 - 3,4 mm	0,3 - 8 mm	0,5 - 13 mm	2,5 - 16 mm
Max. run-out variation at a tightening torque	< 5 μm * from 1.5 Nm	0.03 mm * from 8 Nm	0.03 mm * from 15 Nm	0.03 mm * from 15 Nm
Holding torque at a tightening torque	4.5 Nm ** from 1.5 Nm	18 Nm ** of 8 Nm	40 Nm ** from 15 Nm	45 Nm ** from 15 Nm
Maximum permissible tightening torque	2 Nm	10 Nm	20 Nm	20 Nm
Holding torque at a tightening torque	6 Nm ** from 2 Nm	30 Nm ** from 10 Nm	80 Nm ** from 20 Nm	90 Nm ** from 20 Nm
Max. permissible spindle speed	60.000 min^{-1} ***	35.000 min^{-1} ***	35.000 min^{-1} ***	35.000 min^{-1} ***

Technical data standard

Clamping range	0,5 - 13 mm	2,5 - 16 mm
Max. run-out variation at a tightening torque	< 50 μm	< 50 μm
Holding torque at a tightening torque	70 Nm	80 Nm
Spindle speed – unbalanced	7.000 rpm	7.000 rpm

* Run-out variation check as per WTE "Precision" inspection report.

** All precision drill chucks are clamped at the side via a bevel gear using a hexagonal T-key (see operating manual).

A tightening torque of 8 Nm or 15 Nm on the hexagonal T-key is sufficient to use the drill chuck. The higher holding torques that can be achieved with the precision drill chucks are for additional safety and are not necessary for normal usage.

*** The precision drill chucks are fine balanced as per the catalogue data.

For the use of high spindle speeds, the drill chuck must also be balanced as per the balancing classes – taking into account the spindle speed and balancing value.

Handling notes for hydraulic chucks

Checking the minimum number of rotations



Figure 1:
Turn the clamping screw and the tool test piece

1. Clean and degrease the tool test piece and the location bore (for more information see the brief instructions for the corresponding hydraulic chuck).
2. Insert the tool test piece into the chuck to be tested.
3. Turn the clamping screw with a hex-wrench until the tool test piece in the chuck can no longer be turned by hand (see Figure 1).
4. Tighten the clamping screw to the stop with a hex-wrench observing the minimum turns – see operating manual.

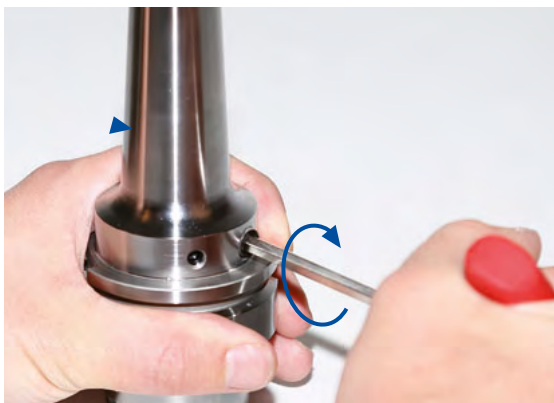

Figure 2:
Tighten the clamping screw and observe the minimum revolutions

Notes

Handling notes for side lock chuck MillChuck, System HB

Clamping a tool

Note:

Only clamp undamaged tools and tools that are free from burrs.

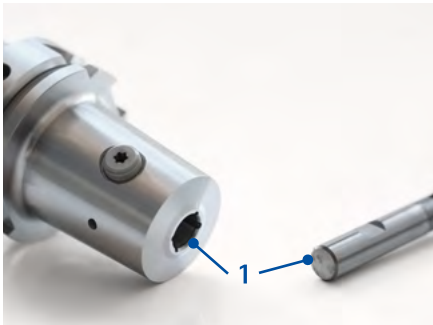

1. Clean the location bore and the tool shank (position 1).

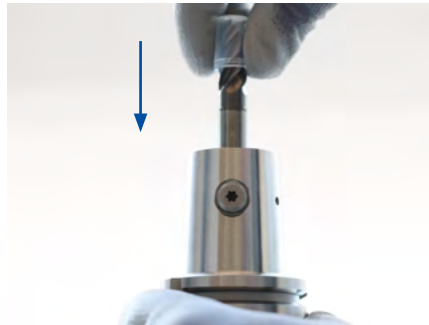

Note:

To ensure correct tool clamping, the HB surface of the tool must face the clamping screw.

1. Push the tool, starting with the shank, into the location bore of the side lock chuck. The recess on the tool must be directed towards the clamping screw.

Comment:

- For trained personnel only.
- Wear protective gloves.
- It is recommended that you handle the tool with a protective cap.

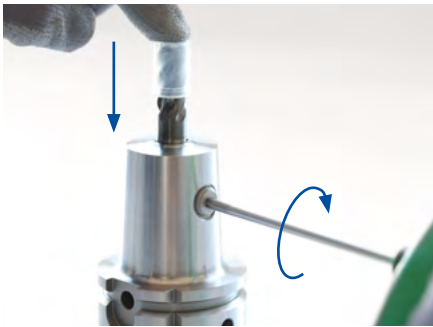

1. Press on the tool from above. At the same time, turn the clamping screw clockwise until it stops.
 - The clamping screw is in contact with the HB surface on the tool.
2. Turn the clamping screw back half a turn.



1. A torque wrench to the specified tightening torque (see Table "Tightening torques for the clamping screw").
2. Tighten the clamping screw until it stops using the torque wrench.

Result:

The tool is completely clamped in the mill chuck and can be used.

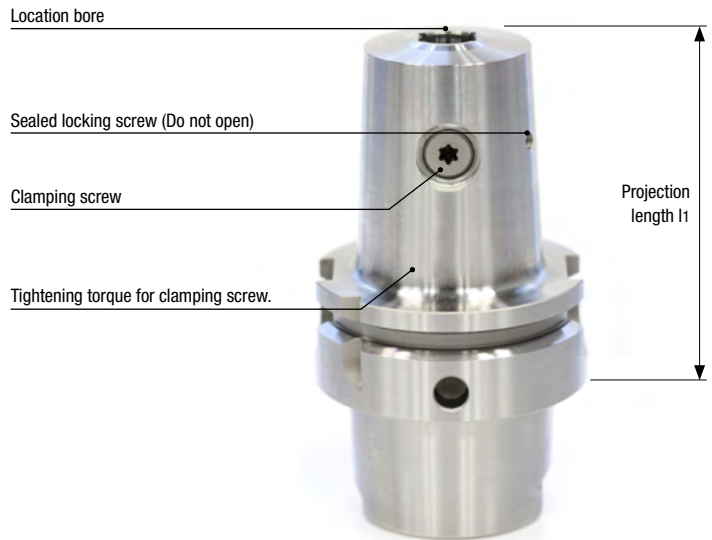

Unclamping a tool

Note:

The clamping screw is not secured from accidentally falling out.



1. Loosen the clamping screw by turning it counter clockwise.

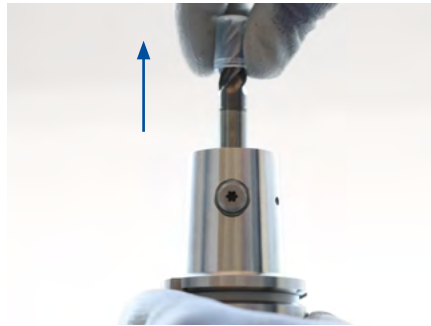

1. Remove the tool from the mill chuck's location bore.

Result:

The tool has been removed.

Tightening torques for clamping screw

Diameter tool shank [mm]	Tightening torque [Nm]	Torx size
6	10	T15
8	10	T25
10	7	T25
12	13	T30
14	13	T30
16	23	T40
18	23	T40
20	25	T40
25	47	T50
32	50	T50

Instructions for handling the milling cutter arbor with vibration damper

Mounting a tool

Note:

Whenever you change tools, make sure that all components of the milling cutter arbor and tool are free of dirt, grease and damage.

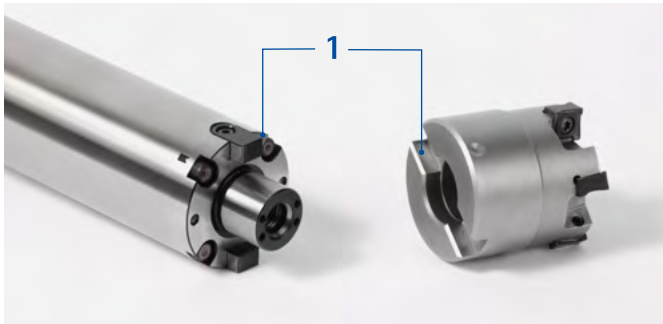

1. Clean the connection areas of the milling cutter arbor and the tool (1).



1. Clamp the milling cutter arbor in a changing device.
2. Place the tool, with bore and face connection in front, on the face connection of the milling cutter arbor.
 - The key block slot of the tool is positioned on the key block of the milling cutter arbor.
3. Lightly screw the milling cutter clamping screw into the threaded bore of the milling cutter



1. arbor by hand.



1. Adjust a torque wrench to the tightening torque required by the milling cutter manufacturer.
2. Use the torque wrench to tighten the milling cutter clamping screw until it stops.

Result:

The tool is clamped onto the milling cutter arbor with the milling cutter clamping screw and can be used.

Removing a tool



1. Loosen the milling cutter clamping screw, for example by using the torque wrench.



1. Unscrew the milling cutter clamping screw from the threaded bore and remove it.



1. Remove the tool from the milling cutter arbor.

Result: The tool has been removed.



- 1 Milling cutter clamping screw
- 2 Key block
- 3 Connection arbor
- 4 Vibration dampening thanks to absorber system
- 5 Threaded bore
- 6 Colour-sealed sealing screw

Your specialist
for high accuracy chucks

Hydraulic chuck
HPH - High Performance Holder
Shrink chuck
CNC precision drill chucks
Standard NC drill chucks
MICRO universal chucks
Services

wte.mapal.com



Order No. 10172942 | V1.0.1