

correa

VERXA

Bridge type milling machine

WARRANTY



75 YEARS
ANNIVERSARY
1947 · 2022

Nicolás Correa, founded in Spain in 1947, is one of world's leading companies in the manufacturing of large milling machines. With over 900 bridge type machines, 1000 floor type machines and 3500 bed type machines installed all over the world, offers milling solutions designed for the most demanding production environments, such as the power generation, automotive, aerospace and railway industries.

Nicolás Correa is the parent company of **Correa Group** composed of five industrial subsidiaries linked to the machine tool sector: Hypatia, Steelworks, Electrónica, Service and Kunming. The Group has commercial subsidiaries in China, Germany, United States and India with the aim to offer the best service in all countries. Belonging to the group provides **Nicolás Correa** with access to top quality critical supplies and offers tailored solutions especially designed for each customer's needs.



Thousands of customers around the world place their trust in **correa** range of milling machines. **Correa Group** currently exports around 90% of its production to over 30 different countries. To guarantee a high-quality service to our customers, we have an extensive international commercial and technical service network in most of the world's countries. **Correa Group** offers the widest range of milling solutions on the market, including bed type machines, gantry, floor type machines, bridge type machines, it also has a several options of multi-tasking machines. The entire range is designed and manufactured in Spain. **Nicolás Correa, S.A.** has been listed on the Madrid Stock Exchange since 1989.

The **VERXA** represents the concept of a high-performance bridge-type machine with mobile table. Its structural design and thermal symmetry permit machining of large parts while maintaining high dynamics and geometric precision.

In all families
VERXA,
FOX and
ORIX

- Steel torsion bars in the crossbeam.
- Minimising the deformation due to crossbeam flexion and torsion.
- Enhancing the geometry of the machine.
- Increasing the roughing capacity .



Double mechanical pull stud system. It avoids the use of electronic corrections and allows a fine mechanical adjustment that minimises angular errors at the tool tip.



THERMO SYMMETRICAL DESIGN

- Symmetrically guided ram.
- Ram symmetrically centred over chassis.
- Improved geometric performance faced with temperature variations in the workshop.

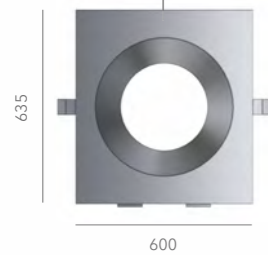
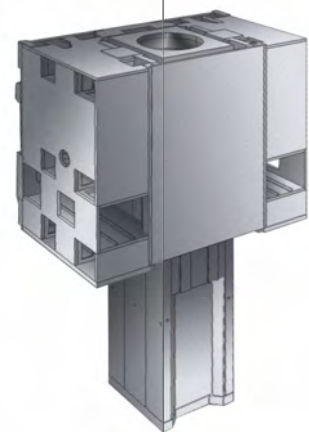

MORE ABOUT THE VERXA



- Specific electrospindle designed to obtain superb finishes at high rpms.
- Machine designed to obtain superb quality surface finishes.
- Dynamic performance parametrizable in accordance with:
 - ROUGHING OPERATION
 - FINISHING OPERATION



MACHINE DYNAMIC ADJUSTMENT

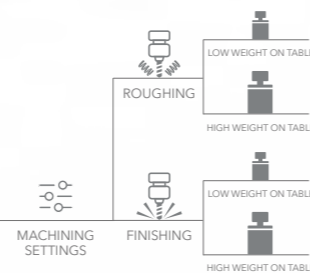

OVERSIZED STRUCTURAL ELEMENTS



HIGH GEOMETRICAL PRECISION

Great cross sections.
Great roughing capacity.
Geometric stability in time.

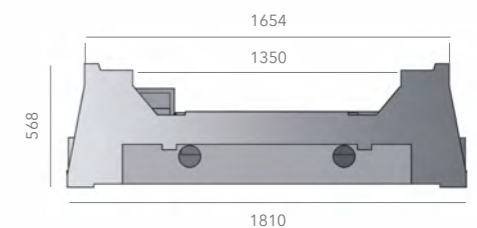
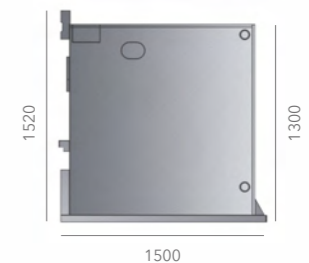

30 m/min in X, Y and Z axes, thanks to its V-Shaped linear guide-ways in all axes



HIGH FEED RATES



ECO DESIGN

Stand-by function and Auto Switch off function, saving 20% of the total energy machine consumption

Technical Features

TABLE

Surface	5700 / 14700 x 2500 / 3000	mm
Maximum load on the table	30 / 50	t

TRAVERSES

Longitudinal [X]	6000 / 15000	mm
Cross [Y]	3750 / 4250 / 5250	mm
Vertical [Z]	1500 / 2000 / 2500	mm

WORK CAPACITY

Distance between columns	3250	3750	4750	mm
Distance between head nose (UAD) and table top	1640 / 2140 / 2640	mm		

FEEDS

Maximum [X]	30	m/min
Maximum [Y]	30	m/min
Maximum [Z]	30	m/min

SPINDLE SPECIFICATIONS

Spindle nose	ISO-50 Big Plus / HSK-100
Programmable speed	10000 / 6000 rpm
Maximum power	42 / 52 kW
Maximum torque	620 / 1375 Nm

External Dimensions

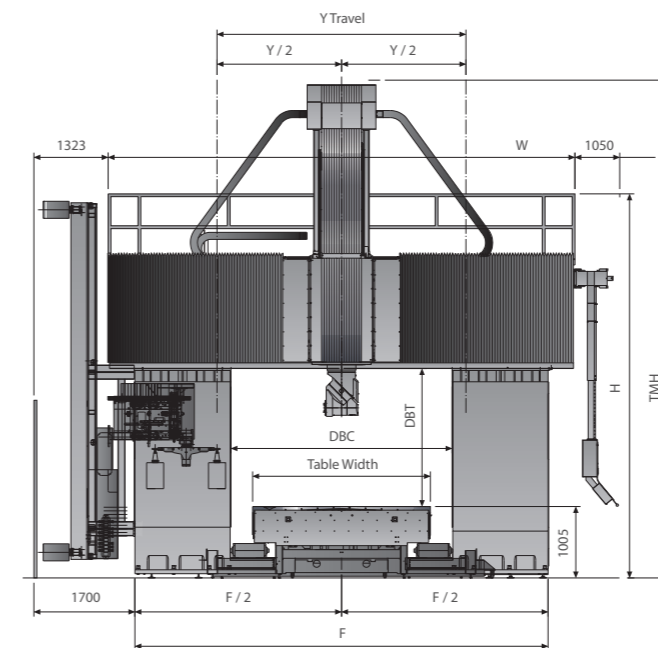

Z Travel	Vert. Capacity	DBT	H	TMH
1500	C	2190	5650	7500
	D	2440	5900	7750
	E	2690	6150	8000
2000	E	2690	6150	8500
	F	2940	6400	8750
2500	G	3690	7150	9500

Y Travel	DBC	F	W
3750	3250	5745	6504
4250	3750	6245	7004
5250	4750	7245	8104

Model	X Travel	Xcac Travel	A	B	C
VERXA 55	6000	5500	11250	14750	17440
VERXA 70	7500	7000	14250	17950	20640
VERXA 85	9000	8500	17250	21150	23840
VERXA 100	10500	10000	20250	24350	27040
VERXA 115	12000	11500	23250	28050	30740
VERXA 130	13500	13000	26250	31750	34440
VERXA 145	15000	14500	29250	33350	36040

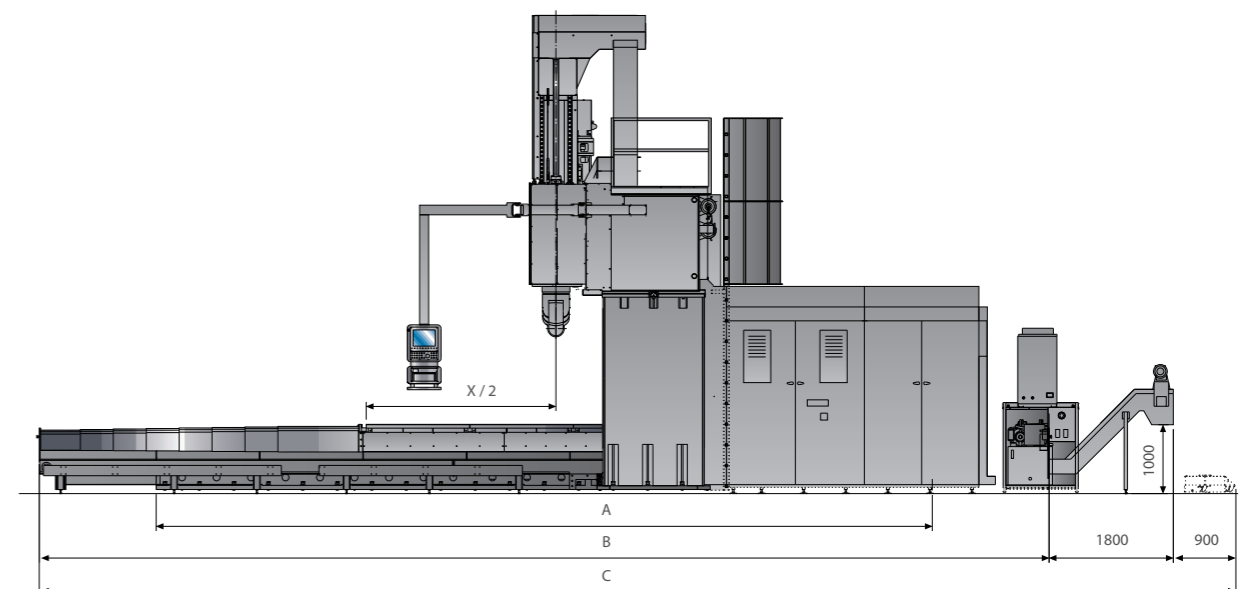

VERXA

Bridge type milling machine

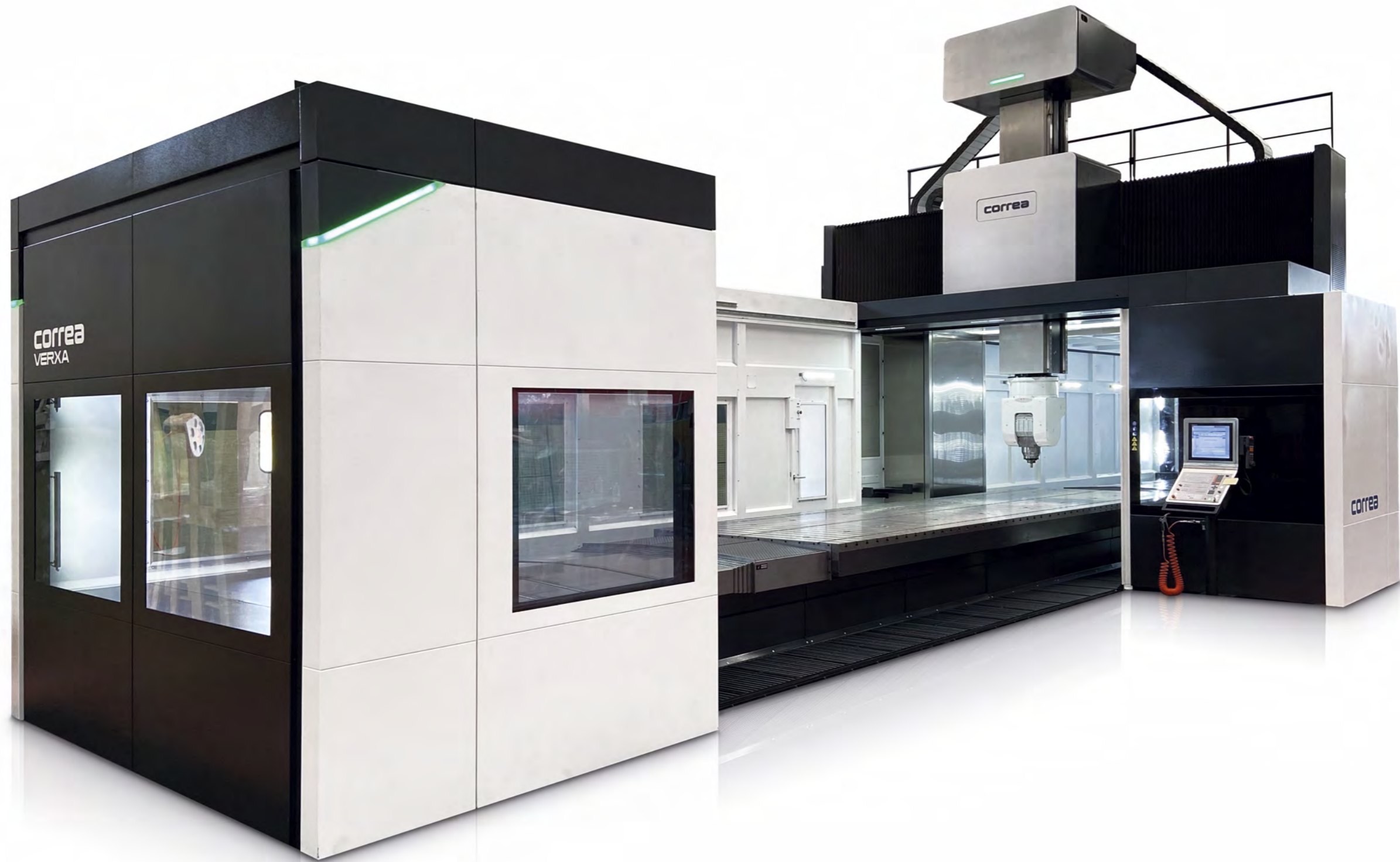

Milling Heads

UAD 0.02° x 0.02°

3+2 INDEXING TECHNOLOGY



Universal auto-indexing
differential head
52 kW | 1375 Nm | 6000 rpm

OAD 0.02° x 0.02°

3+2 INDEXING TECHNOLOGY



Orthogonal auto-indexing
differential head
52 kW | 1375 Nm | 6000 rpm

Milling Heads

UDX 0.02° x 0.02°

3+2 INDEXING TECHNOLOGY



Universal auto-indexing head
42 kW | 620 Nm | 10000 rpm

UCE Universal

5-AXIS TECHNOLOGY



2-Axis continuous
milling head
24000 rpm

Milling Heads

FCT



High torque front spindle
52 kW | 2005 Nm | 4000 rpm



FC-30 | 60 | 80

Front spindle
15 • 52 kW | 1375 Nm | 4000 • 6000 rpm



FD-30 | 60 | 80

3+2 INDEXING TECHNOLOGY
Non-centered front spindle
15 • 52 kW | 1375 Nm | 4000 • 6000 rpm

AL-600 2.5°

3+2 INDEXING TECHNOLOGY



Reach-out angle milling head
25 kW | 800 Nm | 1500 rpm

Milling Heads

ESE Continuous

5-AXIS TECHNOLOGY



2-Axis continuous milling head
35 • 60 kW | 12000 • 24000 rpm



UT-500 | 630

MULTITASKING TECHNOLOGY
D'Andrea head
52 kW | 8000 Nm | 315, 250 rpm



TU 2.5°

MULTITASKING TECHNOLOGY
Turning and shaping head

CSE

5-AXIS TECHNOLOGY



2-Axis continuous milling head
37 kW | 371 • 707 Nm | 4000 rpm

Milling Head Changer



Standard Equipment

- Automatic Universal Head • Hydraulic and cooling group
- Numerical control Heidenhain or Siemens [operate HMI] • Linear scales in all axes
- Portable handwheel • External Coolant with adjustable nozzles
- Air-conditioned electrical cabinet • Internal and external air flow
- Linear guides in the X, Y and Z axes • Guarding
- Lamp in the working area • Tele-service

Optional Equipment

- Other heads • Vixion 4.0
- Automatic head-changer • Self cleaning filter
- Pick up station for 6, 8, 12 tools • Air/Coolant cleaning gun
- Automatic charger for 30, 40, 60, 120 tools • Chip conveyors
- Probes of measurement, tools and parts • Perimeter fence
- Rotary tables • Different enclosures according to user's needs [only in some models]
- Zero Point Clamping System integrated in the machine • Coolant through spindle 17, 36, 70 bar



MULTITASKING

correa multitasking machines combine several cutting processes on one machine. These machines offer the manufacturing capabilities of milling and turning machines into one integrated unit to use the functionality of both simultaneously.

UAD T

The universal head **UAD T** incorporates a spindle internal brake to lock the spindle axis. This solution allows to rotate the turning tool to any position and lock the spindle accordingly. This is a mechanical transmission head providing a perfect integration between milling and turning.



General Specifications

Tool holder HSK-100 for both milling and turning tools. In case of turning tools HSK-100T is required.

Milling mode: 6000 rpm and rotation every 0.02° in both bodies.

Turning mode: Rotation every 0.02° in both bodies.

TU

Orthogonal turning head **TU** rotates every 2.5° thanks to the crown hirth coupling allows to position the tools. We can use neutral tools for turning providing the angel with the head position, reducing the number of tools needed.



General Specifications

Tool holder Capto C8.

Rotation every 2.5° to reduce the number of turning tools to be used.

Automatic tool changing.

TU 25

Turning head **TU 25** incorporates two tapers to 90°. The two tapers offer flexibility to perform several facing and turning operations on a workpiece.



General Specifications

Tool holder Capto C8.

Double two tapers to 90°.

Manual tool change.

	Material	Ø (mm)	Ap (mm)	Vc (m/min)	F (mm/min)	Q (cm³/min)
Medium Duty Roughing	Ck-45 (60 kg/mm²)	1090	4.5	210	0.5	471
Heavy Duty Roughing	Ck-45 (60 kg/mm²)	1200	10	210	0.7	1450

TUB

For internal turning operations in deep parts, Nicolás Correa has specifically designed a manual extension which includes a tuned mass absorber (TMA) internally for a better cutting performance.

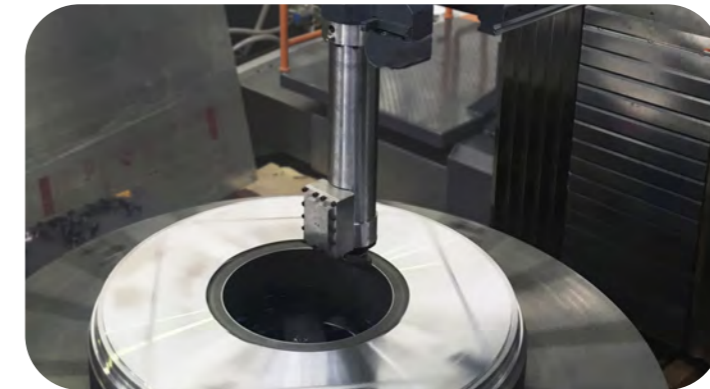

TURNING ROTARY TABLE

	Ø 2000 mm	Ø 2500 mm	Ø 3000 mm	
Maximum load milling/turning	5 - 20	10 - 30	10 - 60	t
Speed	250 - 150	250 - 150 - 120	250 - 150 - 100	rpm



Range of Equipment



TOP GANTRY TYPE

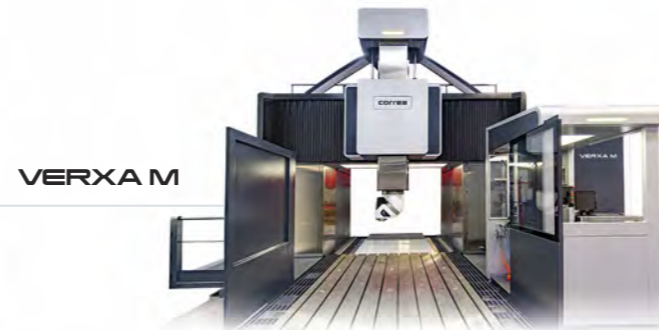

GANTRY



BRIDGE TYPE

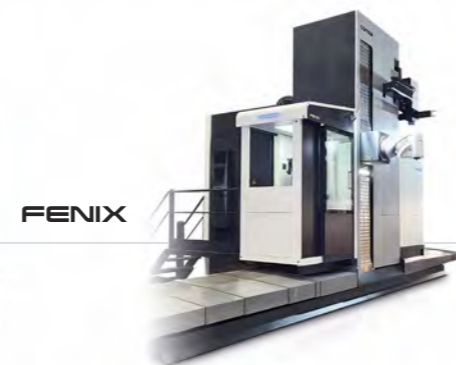
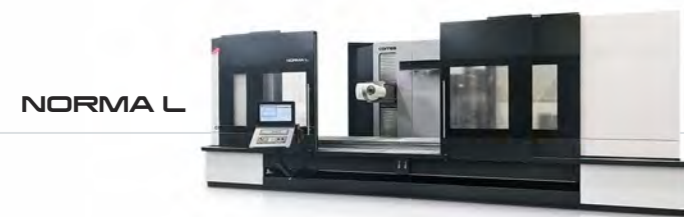

TRAVELLING COLUMN



BED TYPE

CORREA GROUP

www.nicolascorrea.com

Nicolás Correa, S.A.

Alcalde Martín Cobos, 16-A
09007 Burgos • Spain

Phone: +34 947 288 100

Fax: +34 947 288 117

correa@correa.es

