

correa

# XPERTA

Bed type milling machine

WARRANTY





**75** YEARS  
ANNIVERSARY  
1947 • 2022

**Nicolás Correa**, founded in Spain in 1947, is one of world's leading companies in the manufacturing of large milling machines. With over 900 bridge type machines, 1000 floor type machines and 3500 bed type machines installed all over the world, offers milling solutions designed for the most demanding production environments, such as the power generation, automotive, aerospace and railway industries.

**Nicolás Correa** is the parent company of **Correa Group** composed of five industrial subsidiaries linked to the machine tool sector: Hypatia, Steelworks, Electrónica, Service and Kunming. The Group has commercial subsidiaries in China, Germany, United States and India with the aim to offer the best service in all countries. Belonging to the group provides **Nicolás Correa** with access to top quality critical supplies and offers tailored solutions especially designed for each customer's needs.



Thousands of customers around the world place their trust in **correa** range of milling machines. **Correa Group** currently exports around 90% of its production to over 30 different countries. To guarantee a high-quality service to our customers, we have an extensive international commercial and technical service network in most of the world's countries. **Correa Group** offers the widest range of milling solutions on the market, including bed type machines, gantry, floor type machines, bridge type machines, it also has a several options of multi-tasking machines. The entire range is designed and manufactured in Spain. **Nicolás Correa, S.A.** has been listed on the Madrid Stock Exchange since 1989.



The **XPERTA** represents a new concept in fixed frame, lateral ram machine. Very sturdy thanks to structural elements with large sections together with an L-shaped ram guide system. A high precision thanks to the mechanical ram droop correction system. A flexible machine suitable for machining and finishing operations.



L GUIDE-WAY SYSTEM CONFIGURATION

- L-shaped guide system:
  - Greater rigidity and stability during machining.
  - Greater geometrical precision.
  - Less ram droop effect.
- 6 vertical movement sliders ensuring good machine behaviour.

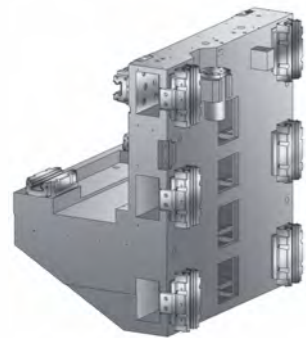
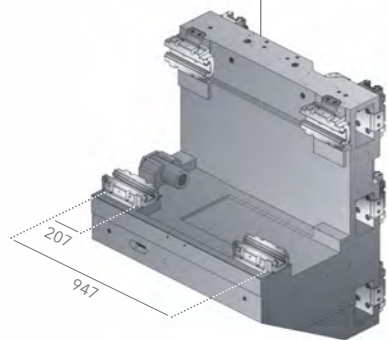

MORE ABOUT THE XPERTA



25 m/min in X, Y and Z axes, thanks to its V-Shaped linear guide-ways in all axes



HIGH FEED RATES



ECO DESIGN

Stand-by function and Auto Switch off function, saving 20% of the total energy machine consumption



MECHANICAL COMPENSATION SYSTEM

Traction bars to eliminate the angular error of the ram droop effect

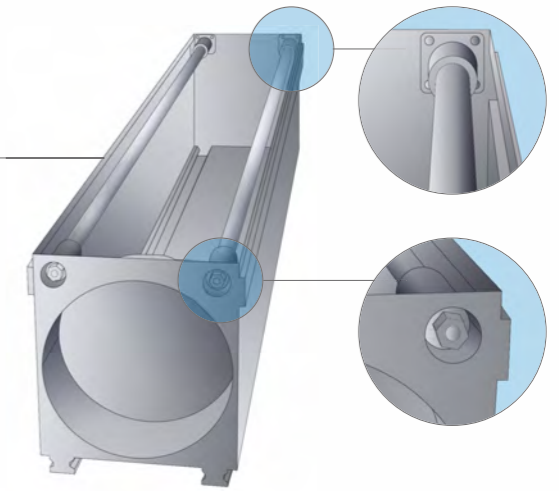

The largest cross-sections on the market.

High machining capacity + geometrical stability over time.



OVERSIZED STRUCTURAL ELEMENTS



HIGH GEOMETRICAL PRECISION

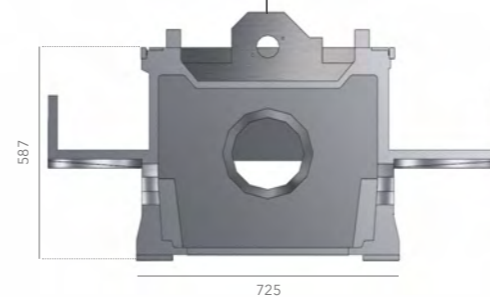
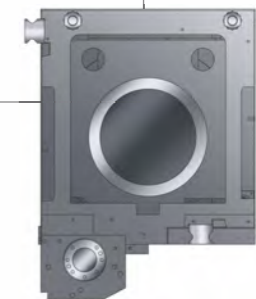

Dynamic performance parametrizable in accordance with:

- ROUGHING OPERATION
- FINISHING OPERATION



MACHINE DYNAMIC ADJUSTMENT

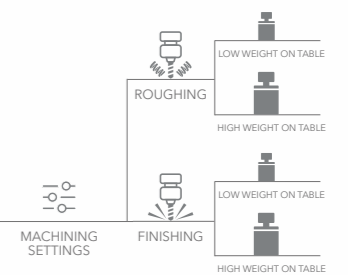

# XPERTA

Bed type milling machine



## Technical Features

XPERTA 20
XPERTA 25
XPERTA 35
XPERTA 45

### TABLE

Table width	2300 / 1000	2800 / 1000	3800 / 1000	4800 / 1000	mm
Maximum load on the table	4.5	6.5	8.5	10.5	t

### INTEGRATED ROTARY TABLE [OPTIONAL]

Diameter	1000	mm
Maximum load	5	t

### TRAVERSES

Longitudinal [X]	2000	2500	3500	4500	mm
Cross [Y]	1000				mm
Vertical [Z]	1000				mm

### FEEDS

Maximum [X]	25	m/min
Maximum [Y]	25	m/min
Maximum [Z]	25	m/min

### SPINDLE SPECIFICATIONS

Spindle nose	ISO-50 Big Plus / HSK-100			
Programmable speed	4000 / 6000 rpm			
Maximum power	24 kW			
Maximum torque	840 Nm			

### WEIGHT

Machine weight	15.2	16.4	18.6	22	t
----------------	------	------	------	----	---

## External Dimensions

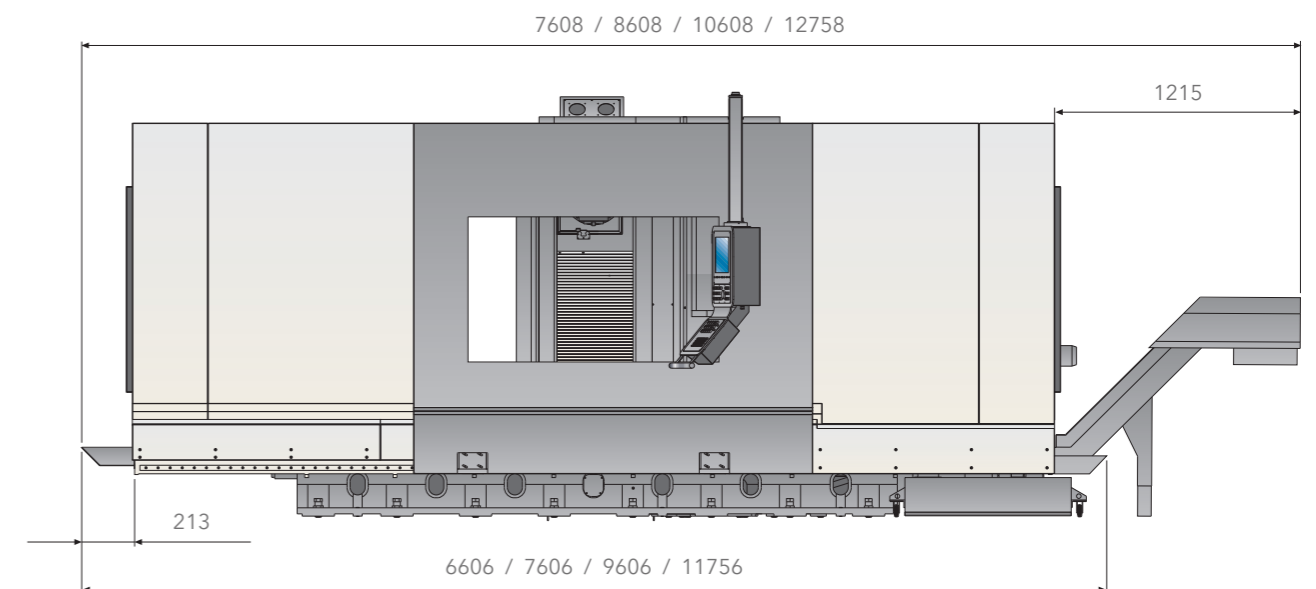
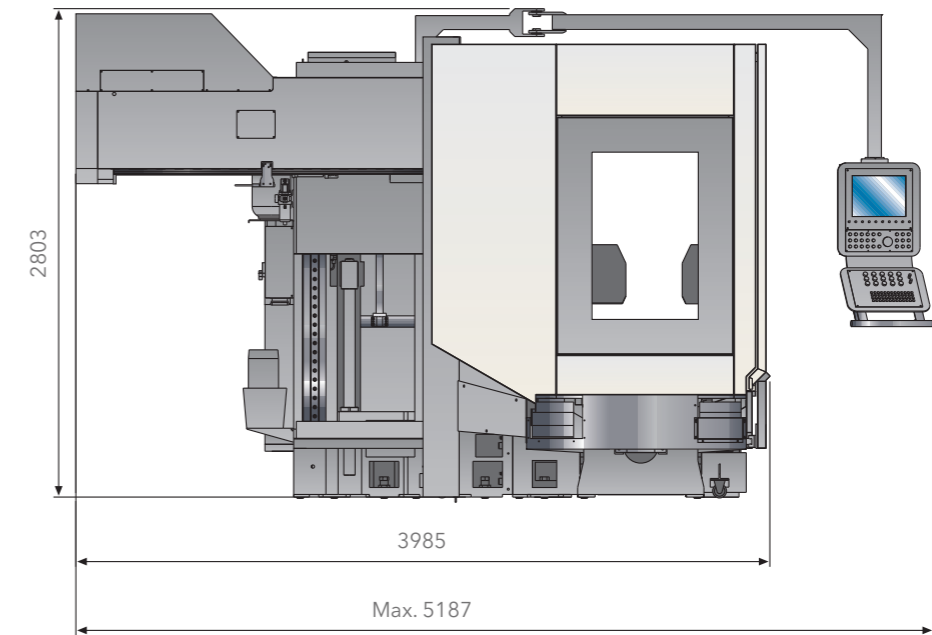

## Milling Heads

### UAD 0.02° x 0.02°

3+2 INDEXING TECHNOLOGY



Universal auto-indexing  
differential head  
24 kW | 840 Nm | 6000 rpm

## Standard Equipment

Automatic Universal Head • Gearbox

Numerical control Heidenhain TNC 640 • Hydraulic group

Portable handwheel • Linear scales in all axes

Air-conditioned electrical cabinet • External Coolant with adjustable nozzles in the head

Linear guides in the X, Y and Z axes • Perimeter fence

Lamp in the working area • Direct Tele-service

## Optional Equipment

Other heads • Vixion 4.0

Pick up station for 8 tools • Centrifugal filter in cutting fluid tank

Automatic charger for 30, 40 and 60 tools • Air or oil cleaning gun with motor pump

Probes of measurement, tools and parts • Coolant through spindle to high and medium pressure

Rotary tables • Chip conveyors

Basic guarding • Integral guarding

### UDG 2.5° x 2.5°

3+2 INDEXING TECHNOLOGY



Universal automatic head  
24 kW | 840 Nm | 4000 rpm



# CORREA GROUP

[www.nicolascorrea.com](http://www.nicolascorrea.com)

## **GNC Hypatia**

Condado de Treviño, 53  
09001 Burgos • Spain  
Phone: +34 947 298 528  
Fax: +34 947 473 520  
[info@gnchypatia.com](mailto:info@gnchypatia.com)

## **Nicolás Correa, S.A.**

Alcalde Martín Cobos, 16-A  
09007 Burgos • Spain  
Phone: +34 947 288 100  
Fax: +34 947 288 117  
[correa@correa.es](mailto:correa@correa.es)

