

correa

# MAGNA

Travelling column milling machine

WARRANTY





**75** YEARS  
ANNIVERSARY  
1947 • 2022

**Nicolás Correa**, founded in Spain in 1947, is one of world's leading companies in the manufacturing of large milling machines. With over 900 bridge type machines, 1000 floor type machines and 3500 bed type machines installed all over the world, offers milling solutions designed for the most demanding production environments, such as the power generation, automotive, aerospace and railway industries.

**Nicolás Correa** is the parent company of **Correa Group** composed of five industrial subsidiaries linked to the machine tool sector: Hypatia, Steelworks, Electrónica, Service and Kunming. The Group has commercial subsidiaries in China, Germany, United States and India with the aim to offer the best service in all countries. Belonging to the group provides **Nicolás Correa** with access to top quality critical supplies and offers tailored solutions especially designed for each customer's needs.



Thousands of customers around the world place their trust in **correa** range of milling machines. **Correa Group** currently exports around 90% of its production to over 30 different countries. To guarantee a high-quality service to our customers, we have an extensive international commercial and technical service network in most of the world's countries. **Correa Group** offers the widest range of milling solutions on the market, including bed type machines, gantry, floor type machines, bridge type machines, it also has a several options of multi-tasking machines. The entire range is designed and manufactured in Spain. **Nicolás Correa, S.A.** has been listed on the Madrid Stock Exchange since 1989.



The **MAGNA** represents the pure box-in-box concept, also incorporating two mechanical systems dynamically compensating for both ram droop and frame tipping. The result: tremendous chip removal capacity, maintaining very high levels of precision throughout the machine's volume.

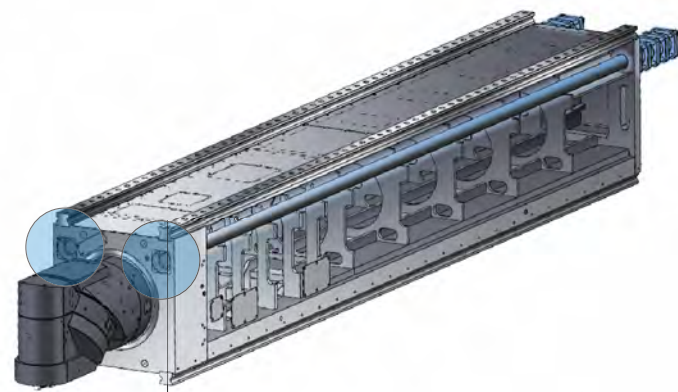

**HIGH GEOMETRICAL PRECISION**

- Mechanical traction bars inside the column to avoid the use of electronic compensations in the vertical axis.
- It improves the roughing capability and the accuracy in the tip of the tool.

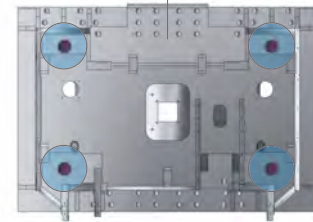

**DYNAMIC COMPENSATION SYSTEM**

- Dynamic ram droop correction system
- Dynamic frame tipping compensation system

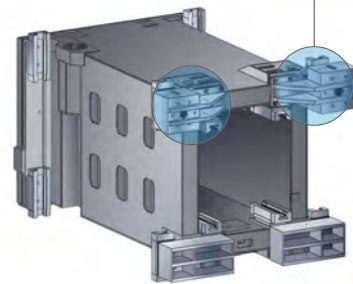

Longitudinal saddle integrated in the machine column as a single monolithic part.

- Maximum sturdiness.
- Maximum geometric precision.
- Minimum column shift error.
- Maximum machining stability.

1812

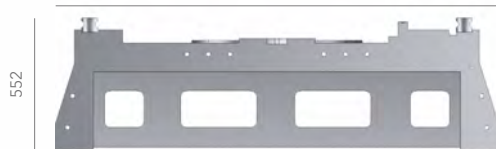

Dynamic performance parametrizable in accordance with:

- ROUGHING OPERATION
- FINISHING OPERATION



**MACHINE DYNAMIC ADJUSTMENT**



**MACHINING SETTINGS**



**ROUGHING**

**FINISHING**



**BOX IN BOX**

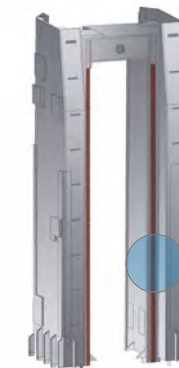

Rear part of the column

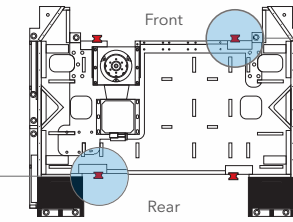

Front

Rear

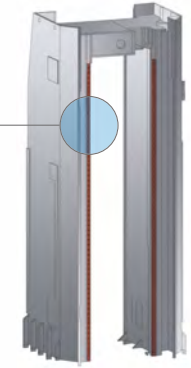

Front part of the column

The biggest cross sections in the market.  
Increase machine stiffness.



**OVERSIZED STRUCTURAL ELEMENTS**

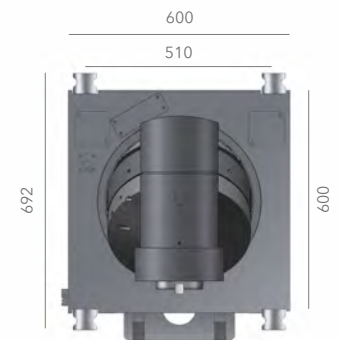

1785



1440

MORE ABOUT THE **MAGNA**



30 m/min in X, Y and Z axes, thanks to its V-Shaped linear guide-ways in all axes



**HIGH FEED RATES**



**ECO DESIGN**

Stand-by function and Auto Switch off function, saving 20% of the total energy machine consumption

## Technical Features

### TABLE

Surface	6000 / 27000 x 2000 / 2500 / 3000	mm
Maximum load on the table	10 / 15	t/m <sup>2</sup>

### TRAVERSES

Longitudinal [X]	6000 / 27000	mm
Cross [Y]	1500 / 2000	mm
Vertical [Z]	4000 / 5000 / 6000 / 7000 / 8000	mm

### FEEDS

Maximum [X]	30	m/min
Maximum [Y]	30	m/min
Maximum [Z]	25 / 20 / 20 / 20 / 20	m/min

### SPINDLE SPECIFICATIONS

Spindle nose	ISO-50 Big Plus / HSK-100	
Programmable speed	10000 / 6000	rpm
Maximum power	42 / 52 / 70	kW
Maximum torque	620 / 1375 / 1500	Nm

## External Dimensions

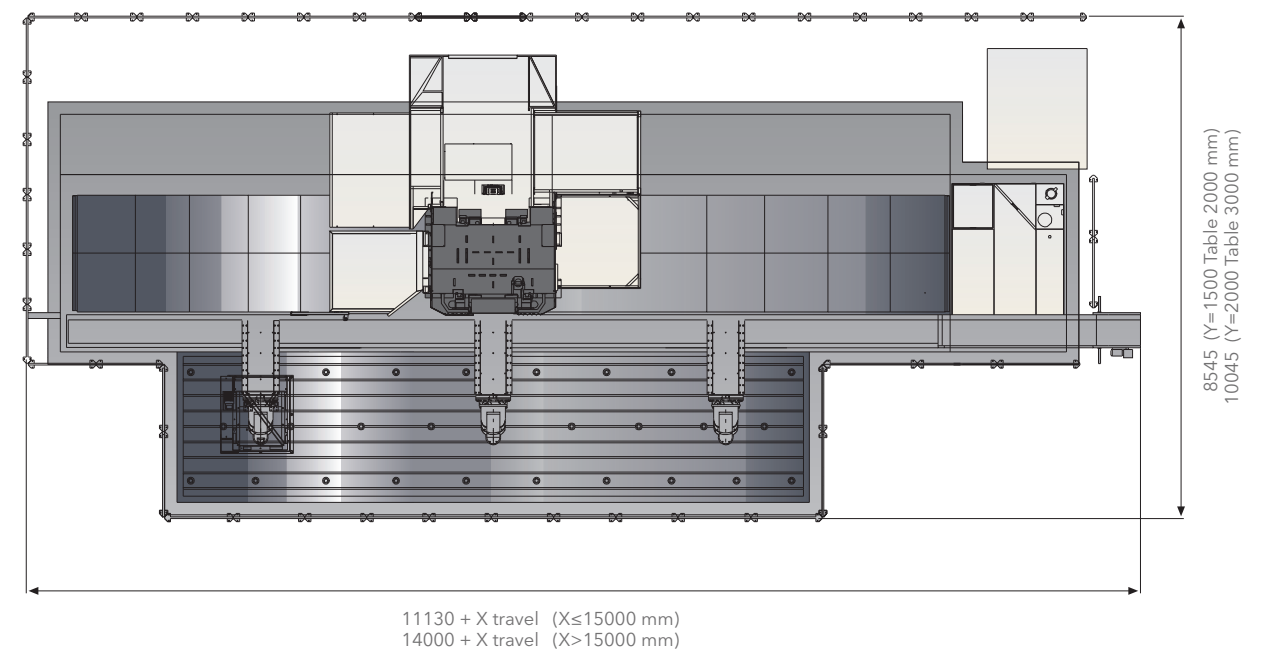
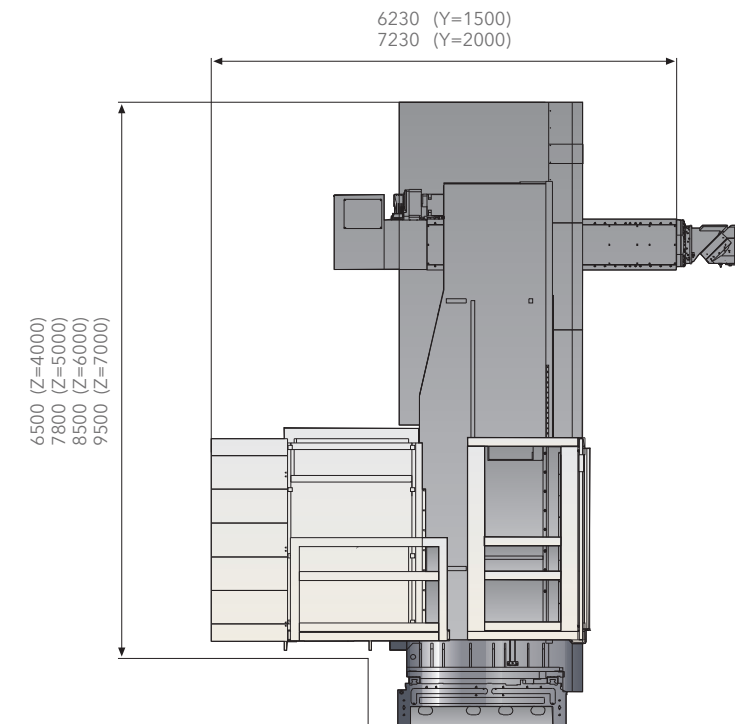

# MAGNA

Travelling column milling machine

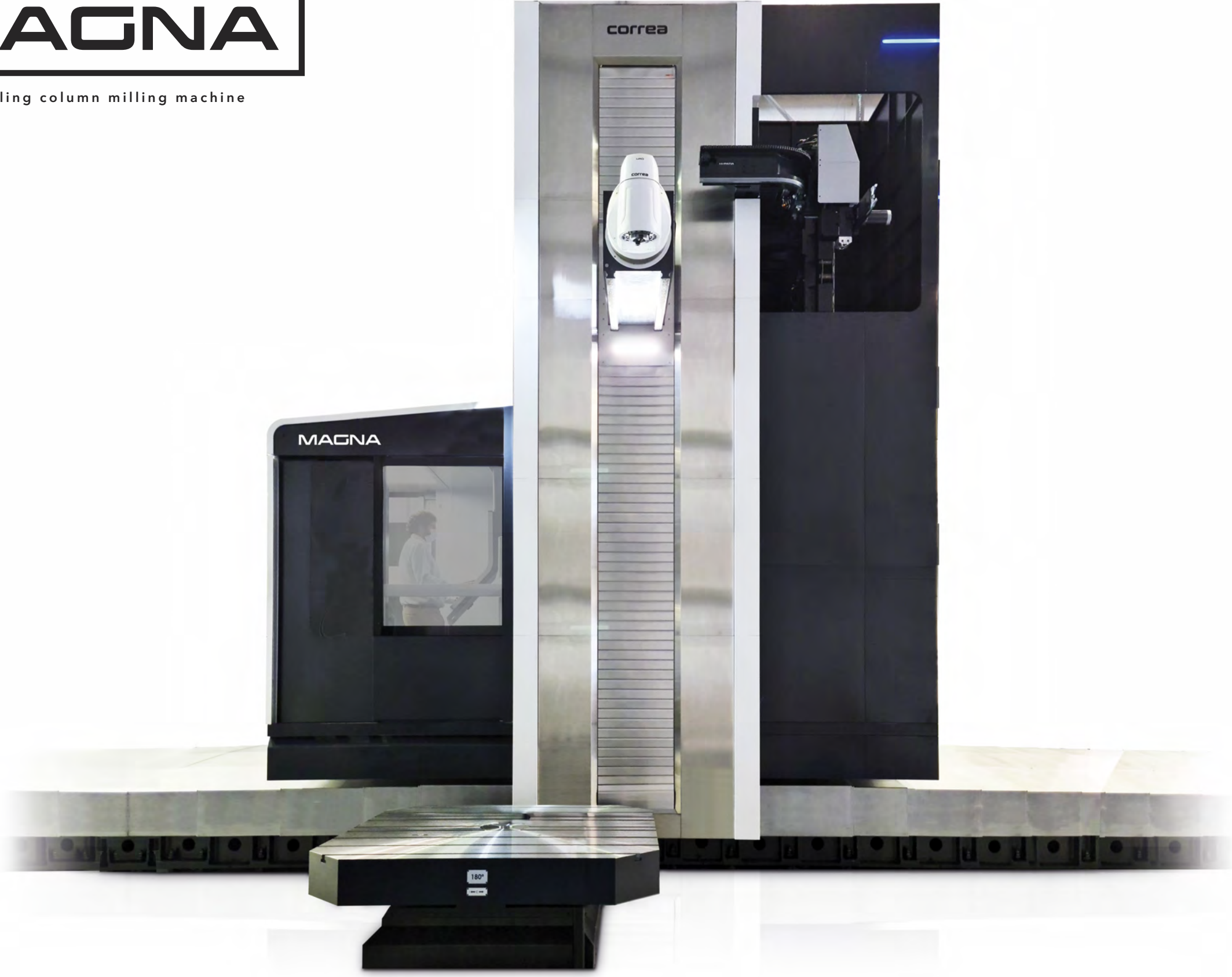

## Milling Heads

### UAD 0.02° x 0.02°

3+2 INDEXING TECHNOLOGY



Universal auto-indexing  
differential head  
52 kW | 1375 Nm | 6000 rpm  
70 kW | 1500 Nm | 6000 rpm

### OAD 0.02° x 0.02°

3+2 INDEXING TECHNOLOGY



Orthogonal auto-indexing  
differential head  
52 kW | 1375 Nm | 6000 rpm

## Milling Heads

### UDX 0.02° x 0.02°

3+2 INDEXING TECHNOLOGY



Universal auto-indexing head  
42 kW | 620 Nm | 10000 rpm

### UCE Universal

5-AXIS TECHNOLOGY



2-Axis continuous  
milling head  
24000 rpm



## Milling Heads

**FC-30 | 60 | 80**



Front spindle  
15 • 70 kW | 1375 • 1500 Nm | 4000 • 6000 rpm

**FCT**



High torque front spindle  
52 kW | 2005 Nm | 4000 rpm  
70 kW | 2267 Nm | 4000 rpm

**ESE Continuous**

5-AXIS TECHNOLOGY



2-Axis continuous milling head  
35 • 60 kW | 12000 • 24000 rpm

## Milling Heads

**AL-600 2.5°**

3+2 INDEXING TECHNOLOGY



Reach-out angle milling head  
25 kW | 800 Nm | 1500 rpm

**UT-500 | 630**

MULTITASKING TECHNOLOGY  
D'Andrea head  
52 kW | 8000 Nm | 315 • 250 rpm



**TU 2.5°**

MULTITASKING TECHNOLOGY  
Turning and shaping head



**FD-30 | 60 | 80**

3+2 INDEXING TECHNOLOGY



Non-centered front spindle  
15 • 52 kW | 1375 Nm | 4000 • 6000 rpm

## Milling Head Changer



## Standard Equipment

- Automatic Universal Head
- Hydraulic and cooling group
- Numerical control Heidenhain or Siemens [operate HMI]
- Linear scales in all axes
- Portable handwheel
- External Coolant with adjustable nozzles in the head
- Air-conditioned electrical cabinet
- Internal and external air flow
- Linear guides in the X, Y and Z axes
- Guarding
- Lamp in the working area
- Tele-service

## Optional Equipment

- Other heads
- Vixion 4.0
- Automatic head-changer
- Self cleaning filter
- Pick up station for 6, 8, 12 tools
- Air/Coolant cleaning gun
- Automatic charger for 30, 40, 60, 120 tools
- Chip conveyors
- Probes of measurement, tools and parts
- Perimeter fence
- Rotary tables
- Different enclosures according to user's needs [only in some models]
- Floor plates
- Coolant through spindle
- Turning tables
- correa** Boring bar system.





MULTITASKING

**correa** multitasking machines combine several cutting processes on one machine. These machines offer the manufacturing capabilities of milling and turning machines into one integrated unit to use the functionality of both simultaneously.

## UAD T

The universal head **UAD T** incorporates a spindle internal brake to lock the spindle axis. This solution allows to rotate the turning tool to any position and lock the spindle accordingly. This is a mechanical transmission head providing a perfect integration between milling and turning.



### General Specifications

Tool holder HSK-100 for both milling and turning tools. In case of turning tools HSK-100T is required.

**Milling mode:** 6000 rpm and rotation every 0.02° in both bodies.

**Turning mode:** Rotation every 0.02° in both bodies.

## TU

Orthogonal turning head **TU** rotates every 2.5° thanks to the crown hirth coupling allows to position the tools. We can use neutral tools for turning providing the angel with the head position, reducing the number of tools needed.



### General Specifications

Tool holder Capto C8.

Rotation every 2.5° to reduce the number of turning tools to be used.

Automatic tool changing.

## TU 25

Turning head **TU 25** incorporates two tapers to 90°. The two tapers offer flexibility to perform several facing and turning operations on a workpiece.



### General Specifications

Tool holder Capto C8.

Double two tapers to 90°.

Manual tool change.

	Material	Ø (mm)	Ap (mm)	Vc (m/min)	F (mm/min)	Q (cm <sup>3</sup> /min)
Medium Duty Roughing	Ck-45 (60 kg/mm <sup>2</sup> )	1090	4.5	210	0.5	471
Heavy Duty Roughing	Ck-45 (60 kg/mm <sup>2</sup> )	1200	10	210	0.7	1450

## TUB

For internal turning operations in deep parts, Nicolás Correa has specifically designed a manual extension which includes a tuned mass absorber (TMA) internally for a better cutting performance.

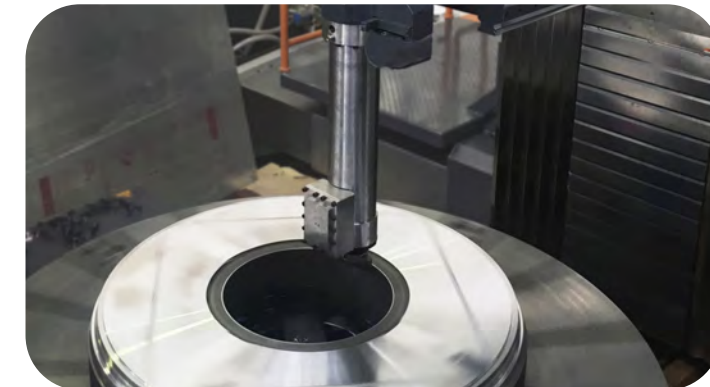

## TURNING ROTARY TABLE

	Ø 2000 mm	Ø 2500 mm	Ø 3000 mm	Ø 4000 mm	Ø 5000 mm	
Maximum load milling/turning	5 - 20	10 - 30	10 - 60	100	150	t
Speed	250 - 150	250 - 150 - 120	250 - 150 - 100	70	70	rpm



# Range of Equipment



TOP GANTRY TYPE

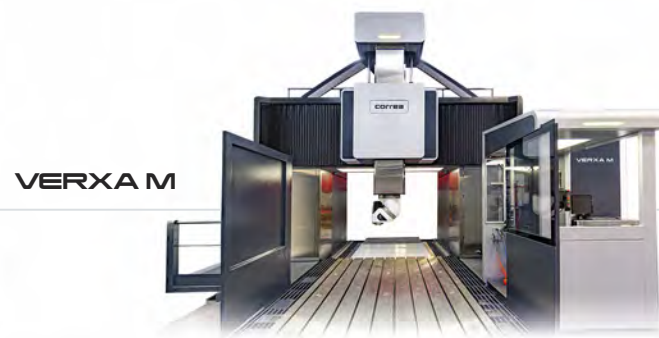

GANTRY



BRIDGE TYPE

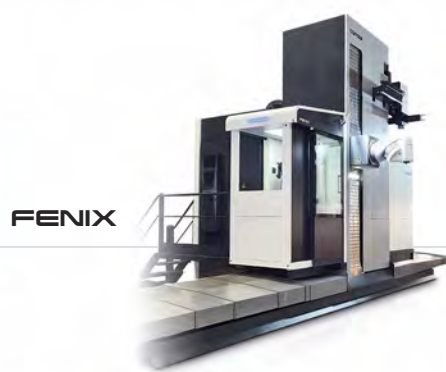
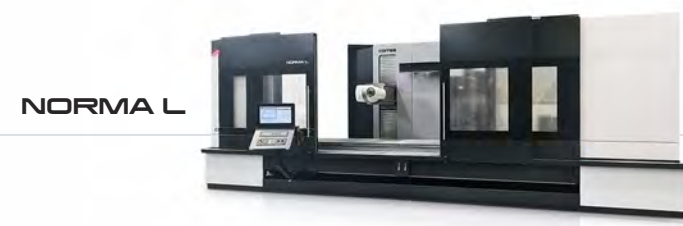

TRAVELLING COLUMN

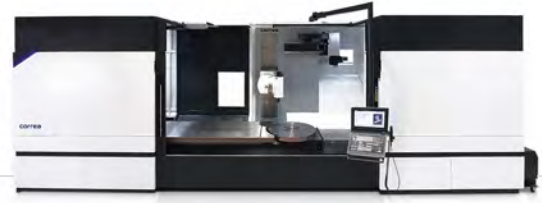

BED TYPE

# CORREA GROUP

[www.nicolascorrea.com](http://www.nicolascorrea.com)

## Nicolás Correa, S.A.

Alcalde Martín Cobos, 16-A  
09007 Burgos • Spain

Phone: +34 947 288 100

Fax: +34 947 288 117

[correa@correa.es](mailto:correa@correa.es)

