

FLA

High-speed 5-axes center for the machining of composite and thermoplastic models and components



THE BEST SOLUTION FOR THE MACHINING OF COMPOSITE, THERMOPLASTIC AND RESIN MATERIALS

Workable materials*

COMPOSITES



PLASTIC



TOOLING BOARDS RESINS



TECHNICAL PLASTIC



LIGHT ALLOYS



* Efficiency indicators by material

Belotti **FLA 5-axes CNC machining centers** combine the productivity of a high-speed milling machine and the potential of a mobile bridge machining center in a single solution.

FLA Series is particularly recommended for:

- the mass production **trimming of components in composite materials** (such as carbon fiber, glass fiber and Kevlar);
- the **milling of resin and light alloys products/models**;
- the **trimming of thermoplastic materials**.

The **wide range of models**, the **high customisation of configurations** and the **special technical features** have supported the wide diffusion of this Series in many industrial sectors: from automotive to aerospace, from railway to marine, from thermoformed to the processing of patterns and moulds.

FLA machining centers guarantee the **maximum production efficiency** thanks to:

- **the excellent dynamism of the axes**
- **the customisation of the machining units**
- **the tool changers with modular design**
- **the automated loading and unloading systems.**

Main application sectors

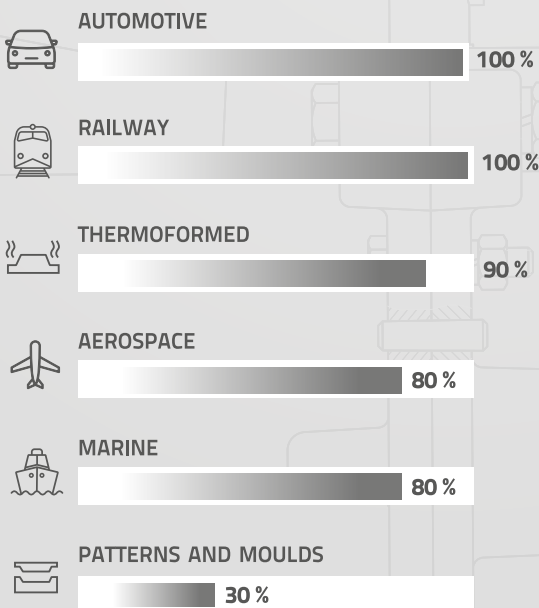

STRUCTURE

FLA Series structure, with **baseframe** or **columns**, is made of extremely high gauge welded heat-treated steel, optimised for the machining of composite materials. These features ensure **high dynamism of the axes** and **quality finishes** throughout the entire life cycle of the machine.

FLA Series machining centers can be set up with different tables for mechanical or vacuum clamping.



- **Models with Y bridge of 2600 mm and 3200 mm** are made with a **columns' structure** that allows to achieve a high versatility in terms of sizes, maintaining high stability and precision during machining operations.



- **Models with Y sliding bridge of 1800 mm** consist of a **rigid baseframe** made of extremely high gauge welded heat-treated steel, for a greater stability and machining accuracy over time.

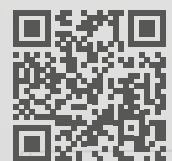

WATCH THE VIDEO





LOADING SYSTEMS

FLA Series can be set-up by choosing from different automated loading/unloading systems, designed to further optimise the production cycle and to offer companies safer and more efficient technological solutions.



Fixed table

The most rigid and precise solution of all, particularly recommended for mechanical clamping of equipment or individual components, with the possibility of managing the production with a dual zone functionality. The working area is divided into two independent zones by means of a central bulkhead: while pieces are loaded/unloaded safely in one zone, the machining cycle continues without interruption in the opposite zone.



Rotary table

The perfect solution to almost zeroing the set-up times, simplifying and speeding up the loading / unloading operations of the workpieces. It consists of two tables with a screen between them which is sealed with the enclosure. It allows to load and unload the machine in the external area, while the machining operations continue inside.



Single shuttle

The solution with a moving platform is designed to separate the loading/unloading area from the working one, providing great advantages.

The model with "through system" allows to obtain two separated working areas.



Twin shuttle

The best technology to maximise the use of the machine. The pieces' loading time is almost zeroed during the production cycle.

The two tables, positioned in front of the machine, can be used independently, in case of dual zone functionality (one table working, the other one loading) or coupled, when required by the dimension of the piece. The working area is separated by an automatic door (or two independent doors) moving vertically, that shifts according to the platform movements.

TOP FEATURES

- **Baseframe or columns structure** for specific production needs.
- **Different automated loading/unloading systems:** fixed table with dual zone functionality, rotary table, single shuttle, twin shuttle.
- **Multi-spindle head special configurations** (revolver or double-exit spindle) for a significant reduction in tool change times. These solutions are recommended for plastics processing.
- **5-axes high performance head with electrospindle up to 22 kW and automatic tool changer** to perform more complex machining operations with one versatile and precise solution, thanks to the pneumatic brakes and the encoders on the rotary axes.
- **Grids, dust suction hoods and total enclosures** for a constant dust and noise reduction.



1



2

OPTIONS

- **Independent double bridge** for simultaneous machining operations on different pieces or on the same piece (4).
- **Linear scales.**
- **Integrated and automatic tool changer up to 30 positions** (1).
- **Rolling shutter or total enclosure** with sound absorbing panels, for dusty and/or high-noise operations (3).
- **Dust extraction system** with electronic suction hood (2).
- **High or low pressure lubro-coolant system** with waste collection special tanks and chips conveyor: the ideal option when machining composite materials and aluminium (4).
- **Ultrasonic technology**, recommended for honeycomb processing (5).
- **"MyB" Suite**, the software for the remote management and integration of the cnc center within the factory environment.



3



4



5

BENEFITS

- **HIGH FLEXIBILITY**, thanks to the wide range of dimensions and to the custom-made options.
- **MAXIMUM SPEED AND MACHINING ACCURACY** through the use of high-performance machining units and electrospindles.
- **INCREASED PRODUCTIVITY AND OPTIMISED CYCLE-TIMES**, with reduction in machining times.
- **CLEANLINESS AND SAFETY OF THE WORKING ENVIRONMENT**, guaranteed by suction systems and protective enclosures.



BELOTTI "MYB" SUITE
BROCHURE DOWNLOAD

TECHNICAL DATA

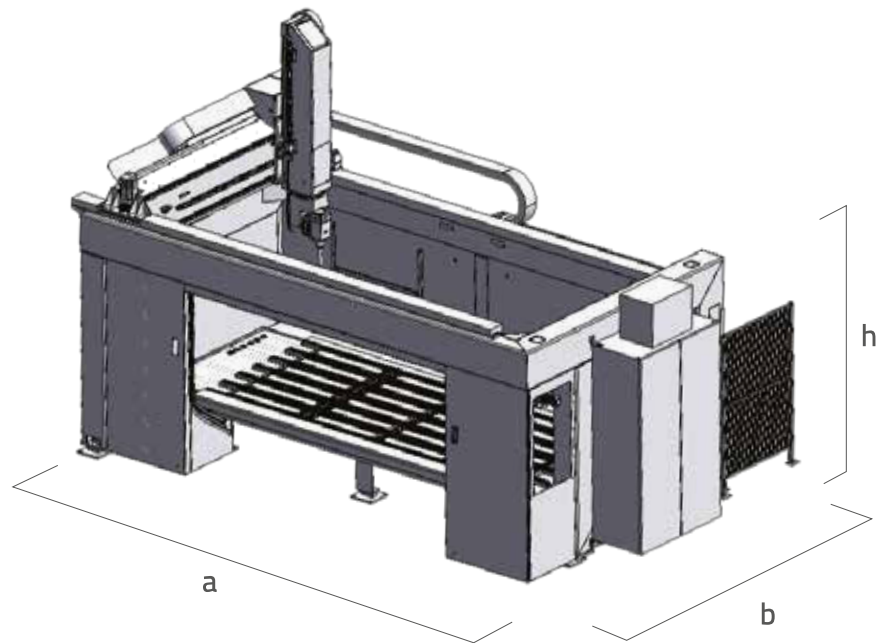

Technical features		BASEFRAME STRUCTURE			
		3018	4018	5018	5518
LINEAR AXES	X (mm)	3.000	4.000	5.000	5.500
	Y (mm)	1.800	1.800	1.800	1.800
	Z (mm)	900	900 / 1.300	900 / 1.300	900 / 1.300
	Positioning accuracy	≤0,030 mm/m			
	Repeatability	≤0,015 mm/m			
	Speed	80 m/min (X, Y axes) ; 60 m/min (Z axis)			
ROTARY AXES	A	+/- 120°			
	C	+/- 270°			
	Positioning accuracy	24 arcsec			
	Repeatability	12 arcsec			
	Speed	44 RPM (C axis); 40 RPM (A axis)			
DIMENSIONS	a (mm)	5.300	6.200	7.400	7.900
	b (mm)	3.200*	3.200*	3.200*	3.200*
	h (mm)	4.100	4.100 / 4.800	4.100 / 4.800	4.100 / 4.800

Working volume (without considering tool holder)

HP 12/15 kW NC HSK-F63 (Pivot 155 mm)	X (mm)	2.690	3.690	4.690	5.190
	Y (mm)	1.490	1.490	1.490	1.490
	Z (mm)	745	745	745	745
HP 15 kW NL HSK-A63 (Pivot 220 mm)	X (mm)	2.560	3.560	4.560	5.060
	Y (mm)	1.360	1.360	1.360	1.360
	Z (mm)	680	680	680	680
HP 22 kW HSK-F63/A63 (Pivot 185 mm)	X (mm)	2.630	3.630	4.630	5.130
	Y (mm)	1.430	1.430	1.430	1.430
	Z (mm)	715	715	715	715

* Consider additional minimum space of:

- about 1.000 mm, in case of tool changer positioned in the rear area
- about 2.500 mm in the machine's front area, in case of twin shuttle solution
- about 2.500 mm on the rear side of the machine, in case of single shuttle solution
- about 3.000 mm in the machine's front area, in case of rotary table solution

CONFIGURATION

FLA

High-speed 5-axes center for the machining of composite and thermoplastic models and components

Electrospindle	From 6,5 kW up to 22 kW from 24.000 RPM
CNC	Fanuc, Heidenhain, Osai, Siemens
Tool changer	From 8 to 30 positions
Technologies	Ultrasonic Waterjet
Enclosure	<ul style="list-style-type: none"> ▪ Total enclosure ▪ Manual or motorised upper rolling shutter
Tables	<ul style="list-style-type: none"> ▪ Aluminium vacuum table ▪ Aluminium vacuum table with T slots ▪ Removable, raised aluminium vacuum table ▪ Steel table with T slots ▪ Resin vacuum table ▪ Resin vacuum table with T slots
Measuring system	Linear scales, 5 micron resolution

COLUMNS STRUCTURE

3026	4026	4032	5026	5526	5532	6526	6532
3.000	4.000	4.000	5.000	5.500	5.500	6.500	6.500
2.600	2.600	3.200	2.600	2.600	3.200	2.600	3.200
1.300	1.300	1.300	1.300	1.300	1.300	1.300	1.300
≤0,030 mm/m							
≤0,015 mm/m							
80 m/min (X, Y axes) ; 60 m/min (Z axis)							
+/- 120°							
+/- 270°							
24 arcsec							
12 arcsec							
44 RPM (C axis) ; 40 RPM (A axis)							
5.600	6.900	6.900	7.800	8.300	8.300	9.600	9.600
5.100*	5.100*	5.700*	5.100*	5.100*	5.700*	5.100*	5.700*
4.900	4.900	4.900	4.900	4.900	4.900	4.900	4.900

2.690	3.690	3.690	4.690	5.190	5.190	6.190	6.190
2.290	2.290	2.890	2.290	2.290	2.890	2.290	2.890
1.145	1.145	1.145	1.145	1.145	1.145	1.145	1.145
2.560	3.590	3.590	4.560	5.060	5.060	6.060	6.060
2.160	2.160	2.760	2.160	2.160	2.760	2.160	2.760
1.080	1.080	1.080	1.080	1.080	1.080	1.080	1.080
2.630	3.630	3.630	4.630	5.130	5.130	6.130	6.130
2.230	2.230	2.830	2.230	2.230	2.830	2.230	2.830
1.115	1.115	1.115	1.115	1.115	1.115	1.115	1.115

The technical specifications and drawings are non-binding. Some photos may show machines equipped with optional features. Belotti S.p.A. reserves the right to carry out modifications without previous notice.



BELOTTI SpA

HQ and Operations 1

Via San G. Bosco, 12 - 24040 Suisio (BG) - ITALY
Tel. +39 035 4934411 - sales@belotti.com

Innovation Hub and Operations 2

Via G. Cassiani, 173 - 41122 Modena - ITALY



Belotti Centro Sud

Via Casale Ferranti, 85
00173 Roma - ITALY
Tel. +39 06 93020906

Belotti America, Inc.

1800 West Loop S STE 1740
Houston TX, 77027 - USA
belottiamerica@belotti.com

Belotti Deutschland GmbH

Kalterer Straße 9
86165 Augsburg / Bayern - GERMANY
Tel. +49 172 5223805

Belotti (Shanghai) Machine Tools Trade Co. Ltd

Room A105, 4th floor (East)
999 Changning Road
Changning District - CHINA

www.belotti.com