

HFC fréza F4260

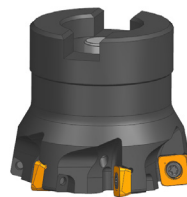

SQUARE MINI

- klidný a kultivovaný chod
- vynikající výkon
- pozitivní VBD se 4 hranami
- robustní výměnná břitová destička
- pro široké spektrum frézovacích operací
- vnitřní chlazení

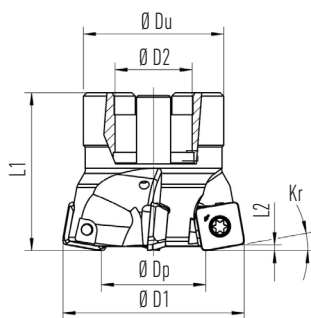

Nástrčné provedení

Objednací číslo	Rozměry (mm)								Destička	Šroubek	Šroubovák	Utahovací moment v Nm
	Dp	D1	D2	Du	L1	L2	Kr	Z				
F4260.40.N16.40.1.Z5.C	26,94	40	16	32	40				SDKW080310 SDKT080315	M3x05 objednací číslo PT009246	XT09	1,4
F4260.50.N22.45.1.Z6.C	36,94	50	22	40	45							
F4260.52.N22.45.1.Z6.C	38,99	52	22	40	45	1	2					
F4260.63.N27.50.1.Z7.C	49,94	63	27	40	50							
F4260.66.N27.50.1.Z7.C	52,94	66	27	48	50							

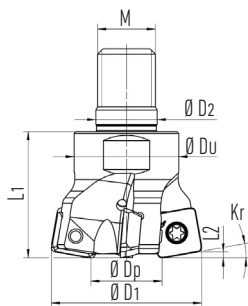

Modulární provedení

Objednací číslo	Rozměry (mm)										Destičky	Šroubek	Klíč	Utahovací moment (Nm)
	Dp	D1	D2	Du	L1	L2	Kr	M	Z					
F4260.20.M10.25.1.Z2.C	7,00	20	10,5	16	25			M10	2	SDKW 080310 SDKT 080315	M3x05 objednací číslo PT009246	XT09	1,4	
F4260.25.M12.28.1.Z3.C	11,96	25	12,5	21	28			M12	3					
F4260.32.M16.35.1.Z4.C	18,95	32	17	29	35	1	2	M16	4					
F4260.35.M16.35.1.Z4.C	21,94	35	17	29	35			M16	4					
F4260.42.M16.35.1.Z5.C	28,94	42	17	29	35			M16	5					

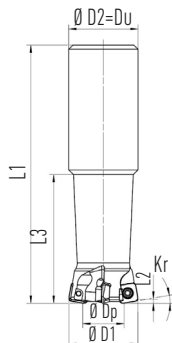

Stopkové provedení

Objednací číslo	Rozměry (mm)								Destičky	Šroubek	Klíč	Utahovací moment (Nm)
	Dp	D1	D2=DU	L1	L2	L3	Kr	Z				
F4260.20.V20.130.75.1.Z2.C	7,00	20	20	130		75		2	SDKW 080310 SDKT 080315	M3x05 objednací číslo PT009246	XT09	1,4
F4260.25.V25.140.80.1.Z3.C	11,96	25	25	140	1	80	2	3				
F4260.32.V32.150.90.1.Z4.C	18,95	32	32	150		90		4				

HFC fréza F4260

SQUARE MINI



Přehled vhodných břitových destiček

Katalogové číslo	P	M	K	S
SDKW 080310-JGP19	●		●	
SDKT 080315-IKM19		●		●

● = 1.volba doporučené

Planžování

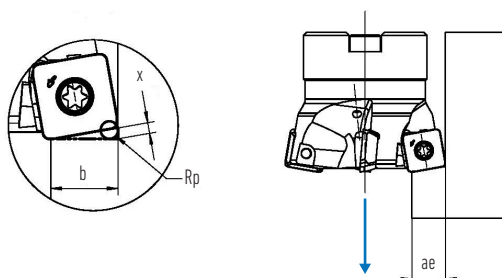

Destička	Program			
	Rp	X	b	ae
SDKW	2,0	0,8	6,8	6,3
SDKT				

Doporučené řezné podmínky

	HB	Povlakovaný druh		Typ utvařeče	
		P19	M19	SDKW	SDKT
		Řezná rychlost Vc (m/min)		Posuv na zub Fz (mm/zub)	
P	Nelegovaná ocel, žíhaná	125 - 220	180 - 250	-	0,40 - 1,80
	Nízkolegovaná ocel, žíhaná	220 - 280	160 - 230	-	0,40 - 1,80
	Vysoce legovaná a nástr., žíhaná	280 - 380	140 - 220	-	0,40 - 1,50
M	Nerezová ocel, ferit./marten., žíhaná	200 - 330	-	140 - 210	-
	Austenitická, kalená ponorem	200 - 330	-	120 - 170	-
	Duplexy	230 - 260	-	100 - 150	-
K	Šedá litina	180 - 245	160 - 270	-	0,40 - 1,80
	Tvárná litina	130 - 230	140 - 250	-	0,40 - 1,80
		160 - 250	120 - 210	-	0,40 - 1,80
S	Superslitiny	200 - 320	-	30 - 110	-

Řezné podmínky ae/D=70%

Destička SDKW



Tvar břitu

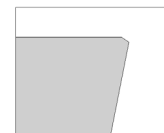

pevný břit pro hrubování oceli, legované oceli, kalené oceli

Destička SDKT

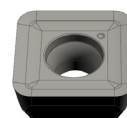

Tvar břitu

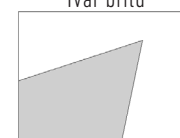

nízká řezná síla pro střední obrábění nerezí a vysokoteplotní slitiny

HFC fréza F4260



SQUARE MINI

Rampování

Ø Dc	Rampování		
	Max Ramp a°	Max ap	Min Lr
20	15	1,0	3,2
25	9,5	1,0	6,0
32	5,5	1,0	10,4
35	4,5	1,0	12,7
40	3,5	1,0	16,3
42	3,5	1,0	16,3
50	3,5	1,0	16,3
52	3,5	1,0	16,3

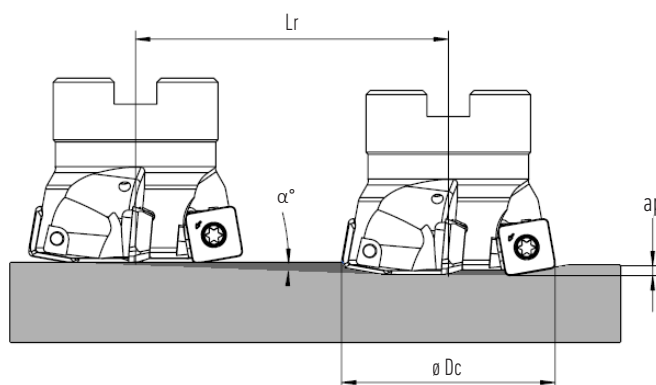

Planžování

L ≤ 3Dc	L > 3Dc	S max.
fz (mm/t)		
0,10-0,20	0,07-0,14	$S_{max} = \sqrt{D \cdot DR - DR^2}$

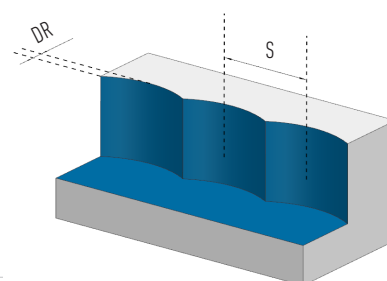

S max a DR korespondující s Dc (mm)

DR (mm)	Dc (mm)							
	20	25	32	35	40	42	50	52
1,0	4,4	4,9	5,6	5,8	6,2	6,4	7,0	7,1
2,0	6,0	6,8	7,7	8,1	8,7	8,9	9,8	10,0
3,0	7,1	8,1	9,3	9,8	10,5	10,8	11,9	12,1
4,0	8,0	9,2	10,6	11,1	12,0	12,3	13,6	13,9
5,0	8,7	10,0	11,6	12,2	13,2	13,6	15,0	15,3
6,0	9,2	10,7	12,5	13,2	14,3	14,7	16,2	16,6